

SMART FIT

25/30/35

**ASSEMBLY AND OPERATING MANUAL OF
GAS BURNING COMBI BOILER DEVICES**



TABLE OF CONTENTS

1 GENERAL INFORMATION	5
1.1 General Informations	5
1.2 Declaration of Conformity	9
1.3 Gas Safety.....	10
1.4 Premix Condensation Technology	10
2 USER INSTRUCTIONS	11
2.1 Introduction.....	11
2.2 What To Do In Case of Gas Leakage	11
2.3 Warnings!	11
2.4 Warranty and Terms of Service	13
2.5 Control Panel	14
2.6 Filling the System	15
2.7 Operating Modes and Start-Up	16
2.8 Diagnosis-Error Codes.....	19
2.9 Automatic Controllers (Optional)	21
2.10 Automatic Operation of the Combi Boiler According to	
the Outdoor Temperature (Optional).....	22
2.11 Solar Connection Kit(Optional).....	23
2.12 Usage with Propane LPG.....	24
3 TECHNICAL SPECIFICATIONS	25
3.1 Technical Specifications Table.....	25
3.2 Product Fiche	26
3.3 Technical Parameters	26
3.4 Dimensions.....	28
3.5 Main Parts of the Combi Boiler.....	29
3.6 Water Circuit.....	30

3.7 Circulation Pump	31
3.8 Electronic Ignition and Control Board - MIAB 3017	33
4 ASSEMBLY INSTRUCTIONS	35
4.1 Relevant Standards	35
4.2 Device Location	36
4.3 Handling and Packaging	36
4.4 Assembling the Device	38
4.5 Water Connections	39
4.6 Proper Heating Installation Pipes	41
4.7 Gas Connection.....	42
4.8 Electrical Connection.....	43
4.9 Flue Connections	45
5 COMMISSIONING THE DEVICE	52
6 PERIODIC MAINTENANCE AND CLEANING	52
6.1 Periodic Maintenance of the Combi Boiler (Authorized Service).....	52
6.2 Maintenance Contents	52
6.3 Cleaning the Combi Boiler (User).....	53
7 CONSUMER RIGHTS	53
8. INFORMATION RELATED TO EFFICIENT USE IN TERMS OF ENERGY CONSUMPTION	55

1. GENERAL INFORMATION

First of all, thank you for choosing ALARKO.

This manual is intended for the SMF 25/30/35 premix condensing, gas burning combi boiler devices that make up the ALARKO Smart Fit combi boiler range. Keep this manual at hand for reference when necessary.

You will be given the necessary information about the use and maintenance of the combi boiler after our authorized dealers have assembled your combi boiler, made its connections and after our authorized services have commissioned it. You can always ask questions about the topics you don't understand. Our experts will be happy to answer them.





To operate your combi boiler safely, efficiently, and economically and to use it smoothly and for a long time, please read this manual carefully and follow the specified safety rules and warnings carefully.

The initial start-up by the authorized service is free of charge and is essential for the warranty of the product.

For more detailed information about your combi boiler, please refer to the product brochure or consult your ALARKO authorized dealer or authorized service. You can find dealer and service information on our Customer Service Line at 444 0 128 or on our website at www.alarko-carrier.com.tr.

The information of all our authorized services is included in the Service Information System created by the Ministry.

1.1 General Warnings

-  The device must be assembled by professional personnel according to the current laws and standards and in accordance with the manufacturer's instructions.
-  "Professional personnel" refers to people who have technical knowledge about the installation and maintenance of central heating and domestic hot water production systems for domestic and industrial use.
-  The device should only be used for heating and domestic hot water production purposes. Any other use will be considered inappropriate and dangerous. The manufacturer assumes no liability for any damage, loss, or injury to persons, animals, or property caused by errors in the installation and/or use of the appliance or failure to comply with existing local and national standards and/or manufacturer's instructions.
-  The assembly and operating manual is an integral part of the product and should always be kept close to the device.
-  This manual should be kept in a safe place and kept handy for reference when necessary. If the device is sold or transferred to someone else, this manual should also be provided with the device to be read by the new user and/or plumber.

- ⚠ For more information, please refer to the product introduction brochure or to our Customer Service Line at 444 0 128 for authorized dealers and services.
 - ⚠ The warnings in this section are written for the device user, plumber, and service representative.
 - ⚠ The operating manual must be read and understood carefully, as it contains information on the operation and operating limits of the device.
 - ⚠ This device should only be used in pressurized heating systems.
 - ⚠ Children should not play with the device. Cleaning and user maintenance should not be done by unattended children.
 - ⚠ This device can be used by children that are 8 years old and above, people with reduced physical, sensory, and mental capabilities, or people without experience and knowledge, if they are supervised or have been given information about the safe use of the device and understand the hazards it contains. Children should not play with the device. If cleaning and user maintenance is to be carried out by children, it must be carried out under supervision.
- After unpacking, check if the device is damaged. In case of any doubt, do not use the product and contact your dealer. Packaging materials (cardboard box, stapler, nylon bag, polyester etc.) should be kept away from children. Since these materials pose a potential hazard, they must be disposed of reliably.
 - Before any cleaning or maintenance, disconnect the device from the mains voltage by switching off the mains switch and/or other disconnecting switches.
 - Do not block the air inlet or flue gas outlet grilles in any way.
 - Do not block the air inlet or flue gas outlet terminals.
 - In case of an error and/or failure in the device, turn off the system. Do not attempt any intervention or repair. Call only a professional and authorized technical service.
 - All warranty repairs of the device will only be carried out by services authorized by the manufacturer, using original spare parts. Failure to comply with the above requirements may compromise the safety of the device and void the warranty. In order to guarantee its efficiency and correct operation, the device must be regularly serviced by an authorized service in accordance with the manufacturer's instructions.
 - When the use of the device is no longer needed, parts that may constitute a potential source of danger should be rendered harmless.
 - Only original accessories or optional parts (including electrical parts) should be used with the device.

-
- As stipulated by the current law, this device shall only be installed by authorized personnel. Before the initial start-up of the combi boiler, make sure that it is connected to a water supply and heating system relevant to the performance specifications.
 - The room must be ventilated by means of an air inlet protected by a grille. Make sure that the grille's air passage is not blocked.
 - The air flow from the adjacent rooms is not a problem provided that these rooms are of lower pressure than the atmosphere and that there is no fireplace or fan installed in these places. When the device is assembled outdoors, for example on a balcony or terrace, make sure that it is not directly exposed to atmospheric factors to prevent damage to its components, which will cause the warranty to become void. The combi boiler must be placed in a protective enclosure/cabinet against bad weather conditions.
 - **Also check the data on the packaging and that the device is suitable for the type of gas to be burned.**
 - **Ensure that the pipes and fittings used in the gas system are tightened enough and that there is no gas leakage.**
 - Before operation, the heating pipes must be flushed to remove sediment and debris that could endanger the operation of the device.
 - The device is considered electrically safe as long as it is connected to an effective grounding system assembled in accordance with current safety standards. This basic safety measure must be checked and verified. In case of doubt, have the electrical system checked by a qualified electrician. The manufacturer shall not be held responsible for any damage or loss of property or life caused by an ineffective grounding system or the absence of a grounding system.
 - Ensure that the electrical supply at the location where the device will be assembled is controlled by a qualified electrician to ensure that the device will support the maximum power absorption shown in the assembly and operating manual. In particular, make sure that the cable dimensions are suitable for the power used by the device.
 - Do not use adapters, multiple plugs, or extension cables to connect the device to mains power.
 - The device must be connected to the mains supply via an appropriate electrical fuse according to the current electrical regulations.

The following basic rules must be followed when using electrical devices:

- Do not touch the device with wet or damp parts of your body or barefoot.
- Do not unplug the power cords.
- Do not expose the device to atmospheric factors (rain, sun, etc.).
- Do not allow children or people to use the device who have no such knowledge.
- The power cord must not be replaced by the user.
- If the cord is damaged in any way, turn off the device and have the cord replaced by an authorized service.

1.2. Declaration of Conformity





AT UYGUNLUK BEYANI

EC DECLARATION OF CONFORMITY

ALARKO – CARRIER SAN. VE TİC. A.Ş.

GOSB – Gebze Organize Sanayi Bölgesi, Şahabettin Bilgisu cad. 41480
Gebze – KOCAELİ / TURKEY

Alarko Carrier San. ve Tic A.Ş. tanımlanmış olan ürünlerin aşağıda bahsedilen yönetmelikler ve standartlara uyum sağladığını beyan eder.

Bu beyan ürünün teslimat durumundaki son şekliyle geçerlidir. Ürün üzerinde yapılacak herhangi bir modifikasyonda, bu beyan geçerliliğini yitirmiş olacaktır.

Ürün, insan sağlığına zararlı "Asbest" maddesi içermez ve imalatında kullanılmamıştır.

Ürün, insan sağlığına zararlı "PCB(Poliklorürlü bifenil)" maddesi içermez ve imalatında kullanılmamıştır.

Ürün, insan sağlığına zararlı "Cıva" maddesi içermez ve imalatında kullanılmamıştır.

Alarko Carrier San. ve Tic A.Ş. declares that the described products are in conformity with the below mentioned directives and standards.

This declaration refers to the product in delivery status. Any modifications of the product will invalidate this declaration.

The product does not contain "Asbestos" material harmful to human health and was not used in its manufacture.

The product does not contain any "PCB (Polychlorinated biphenyl)" substance that is harmful to human health and has not been used in its manufacture.

The product does not contain "Mercury" harmful to human health and was not used in its manufacture.

ÜRÜN TANIMI :

Gaz Yakan Kombi Cihazları

MODEL / TİP :

Smart Fit 25 kW (SMF 25)
Smart Fit 30 kW (SMF 30)
Smart Fit 35 kW (SMF 35)

YÖNETMELİKLER :

2016/426/AB: Gaz Yakan Cihazlara Dair Yönetmelik
92/42/AT: Sıvı ve Gaz Yakıtlı Sıcak Su Kazanlarının Verimlilik Gereklilerine Dair Direktif
2014/35/AB: Alçak Gerilim Yönetmeliği

UYGULANAN UYUMLAŞTIRILMIŞ STANDARTLAR :

EN 15502-1+A1, EN 15502-2-1+A1, TSEN60335-1,
TS EN 60335-2-102, EN 13203-2, EN 55014-1
EN 55014-2, EN 61000-3-2, EN 61000-3-3

PRODUCT DESCRIPTION :

Gas Fired Combi Boilers

MODEL / TYPE :

Smart Fit 25 kW (SMF 25)
Smart Fit 30 kW (SMF 30)
Smart Fit 35 kW (SMF 35)

DIRECTIVES :

2016/426/EU: Regulation on Gas Burning Devices
92/42/EEC: Directive on the Efficiency Requirements of Liquid and Gas Fired Hot Water Boilers
2014/35/EU: Low Voltage Regulation

APPLIED HARMONIZED STANDARDS :

EN 15502-1+A1, EN 15502-2-1+A1, TSEN60335-1,
TS EN 60335-2-102, EN 13203-2, EN 55014-1
EN 55014-2, EN 61000-3-2, EN 61000-3-3

İMALATÇI ADINA – SINGED ON BEHALF OF THE MANUFACTURER

AD_SOYAD – NAME_SURNAME

GÖREV – POSITION

YER / TARİH – PLACE / DATE

İMZA – SIGNATURE

: Murat Çopur

: Genel Md. Yrd./Fabrika Vice President/Factories

: Gebze – Kocaeli / 31.05.2023

:



ALARKO
Carrier
ALARKO CARRIER
SANAYİ VE TİCARET A.Ş.

1.3. Gas Safety

Gas burning devices must be assembled by authorized and knowledgeable persons in accordance with the rules of local gas distribution organizations. Any gas conversion on the device must also be carried out by authorized persons.

This device is manufactured and certified for operation with natural gas or propane LPG gas and at the gas inlet pressures given in Section 3.1. Technical Specifications Table. It is not allowed to operate this device under different gas usage conditions.

The type of gas to which your combi boiler is set is written in the “Gas Usage” section of the type label inside the device, unless it is converted to another type of gas by authorized persons. Be careful not to operate your combi boiler with a different gas type than the one last set.

1.4. Premix Condensation Technology

Thanks to the premix, i.e. heat exchangers with a wide heat transfer surface in gas-air premixed fully condensing combi boilers, the flowing water temperature is produced at or below about 50°C, while the flue gas temperatures fall to 55°C and below.

At flue gas temperatures below 55°C, the water vapor contained in the waste gas condenses, i.e. changes from vapor to liquid phase. In this way, the energy is captured without escaping through the flue and transferred to the water in the exchanger. This is called latent heat energy. By recovering the energy in the water vapor, up to 30% of the fuel money is saved.

Therefore, in order to get the highest efficiency from your combi boiler and operate it in the most economical way, set the heater water temperature to a maximum of 50°C.

Since the condensate water is acidic, the main exchangers of the premix fully condensing combi boilers should be either stainless steel or aluminum alloy resistant to acidic condensate water. Stainless steel main exchangers with very high resistance to condensate water are used in Alarko Smart Fit gas burning combi boiler devices.

With a premix system, i.e. a premix of gas and air in the ideal ratio of 1:10 before burning, burning always takes place ideally. This is achieved by the modulating fan, which adjusts its speed according to the capacity requirement, and the venturi, which ideally mixes the gas and air coming from the modulating gas valve with the traction of the fan.

2. USER INSTRUCTIONS

2.1. Introduction

Following the completion of the assembly and commissioning procedures, the authorized service technician will provide information on the use and maintenance of the combi boiler. You can ask all the questions you can think of to better understand the combi boiler, they will be happy to help you. The commissioning by the authorized service is free of charge.

Before using the combi boiler, read this manual carefully and follow the safety instructions and warnings when using it. This way you will achieve long-term, safe, and most economical use. Additional technical information is provided in this section to introduce the combi boiler.

2.2. What To Do In Case of Gas Leakage

- Calm down.
- EXTINGUISH the fires.
- OPEN all windows and doors.
- CLOSE the valves of all gas devices.
- CLOSE the gas valves at the apartment and building entrance.
- DO NOT light matches, lighters, etc. and DO NOT smoke.
- DO NOT use the light switches, do not turn them off if they are on, do not turn them on if they are off.
- DO NOT operate electrical devices.
- DO NOT pull/insert plugs.
- DO NOT use the bells.
- DO NOT use phones in gas-filled environments.
- Notify the manager, the GAS COMPANY at 187, and the FIRE DEPARTMENT at 110.

2.3. Warnings!

- This device should be used in accordance with its intended use. Alarko Carrier Sanayi ve Ticaret A.Ş. does not accept any liability for damages to persons, animals, or goods due to improper assembly, adjustment, maintenance, misuse, and failure to comply with any of the warnings specified in this manual.
- The places where gas burning devices can be placed are determined by the rules and regulations of gas distribution organizations and local governments. You can learn the details about these places and limitations

from the company that assembles the device. For your own safety first and foremost, DO NOT ask the installers to place your device in unsuitable positions.

- Before making the application of your natural gas installation, the natural gas installation project must be prepared and approved in accordance with the requests of the Natural Gas Distribution Company in your region. After the application is completed and after the approval of the regional natural gas distribution company, have your combi boiler commissioned by Alarko Carrier Authorized Services. Our service will not charge for this operation.
- DO NOT allow unauthorized persons to interfere with your device and provide service.
- Gas conversion operations (from natural gas to LPG and LPG to natural gas) should only be carried out by authorized services. Transformation operations are chargeable.
- DO NOT keep explosive or flammable liquids/solids near the device.
- Do not use spray, solvent, chlorinated cleaning agent, paint and adhesives near the device.
- Do not place a stove near your combi boiler and protect it from direct water vapor. Your device must be connected to a grounded electrical supply of 230 V - 50 Hz.
- If the combi boiler is assembled in a place where there is a risk of freezing, the frost protection can only be activated when the combi boiler is energized and when the gas valve is open. The manufacturer cannot be held responsible for any damages that may occur to the combi boiler if this instruction is not followed.
- In order to prevent damage to the pump fan from foreign substances in the installation, a strainer should be placed in the combi boiler heating return line and cleaned periodically. Contact your Authorized Service for this procedure.
- If the water you fill your device with is too calcareous, it may clog the domestic water exchanger. Your domestic water should have a maximum of 17.5 French hardness.
- The domestic water circuit does not need a safety valve. However, care must be taken that the water mains pressure does not exceed 10 bar. In case of doubt, a pressure reducer should be assembled at the tap water inlet of your apartment. Have this checked by your plumber.

2.4. Warranty and Terms of Service

Provided that the principles, warnings, and standards specified in the user manual are complied with, your device is under 3 (three) years Alarko Carrier warranty against material and manufacturing faults.

The WARRANTY CERTIFICATE must be filled and approved by the dealer from whom you purchased your device and delivered to you.

Alarko Carrier authorized services are at your service even in the slightest problem. You can find Alarko Carrier authorized services at “www.alarko-carrier.com.tr” web address. All our authorized services are registered with the Republic of Turkey Ministry of Commerce SERBIS Service Information System.

If you encounter any problems, you can call Customer Service Line at 444 0 128 from all over Turkey, and you can reach Alarko Carrier Customer Service Department via the internet or e-mail at “info@alarko-carrier.com.tr”.

According to the relevant communiqués of the Ministry of Industry and Trade, the lifetime of the combi boiler is at least 10 (ten) years.

Our company is obliged to keep all kinds of spare parts related to your device during this period.

The warranty is invalid under the following conditions:

Initial commissioning by unauthorized companies and persons. Damages caused by interventions made by unauthorized persons.

Any failure or damage that may occur as a result of disasters such as wars, riots, terrorist acts, fires, thefts, earthquakes, lightning strikes, floods, overheating, or freezing.

Damage that may occur due to unfavorable weather conditions, especially freezing, if the instructions in the user manual are not followed.

Changing or destroying the serial number of the combi boiler.

Assembly, use, and maintenance works that do not comply with the regulations and assembly instructions.

Products used for shows, fairs, and exhibitions.

Failure of the customer to submit the approved warranty certificate or invoice. The risks during the transportation of the combi boiler under the responsibility of the customer belong to the customer.

2.5. Control Panel

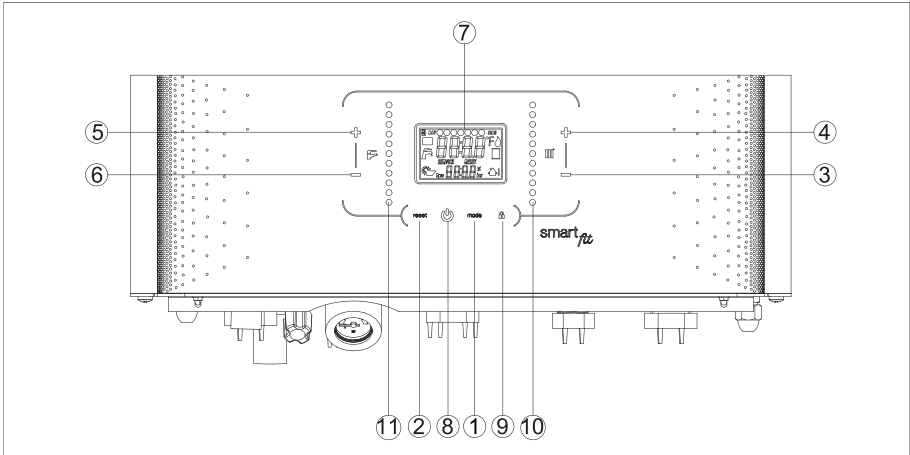

Figure 1. Control Panel

1. Operating position adjustment button (summer / winter / heating only)
2. Reset button
3. Heater water temperature decrease button
4. Heater water temperature increase button
5. Domestic water temperature increase button
6. Domestic water temperature decrease button
7. Temperature, error code, and operating status LCD display
8. On/Off button
9. Lock button
10. Heater water temperature gradually increase/decrease button
11. Domestic water temperature gradually increase/decrease button

2.6. Filling the System

ATTENTION!

The water pressure in the heater circuit must be checked during the combi boiler operation. The system should be filled with water at a pressure of 1.2 bar. The water pressure can be controlled by the manometer positioned in the lower right corner of the combi boiler. Filling must be carried out when the combi boiler is cold and closed.

Smart Fit combi boilers have a manometer on the bottom surface. After all the necessary connections of the combi boiler (electricity, pipes, and flue) are made, filling can be done through the filling tap (D) on the lower left side of the combi boiler (Figure 3).

The filling process should be continued until the pressure value on the manometer reaches 1.2 bar. (Figure 2)

If the water pressure drops below a certain value, the display shows the error E04. Open the filling tap (D) in Figure 3 to increase the pressure in

the system. Check the pressure value on the manometer to avoid overloading the system. Continue filling the system until the pressure reaches 1.2 bar, when this value is reached, close the filling tap.

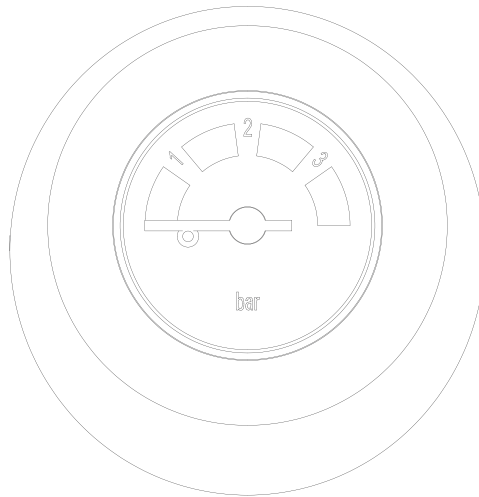

Figure 2. Manometer 1.2 bar

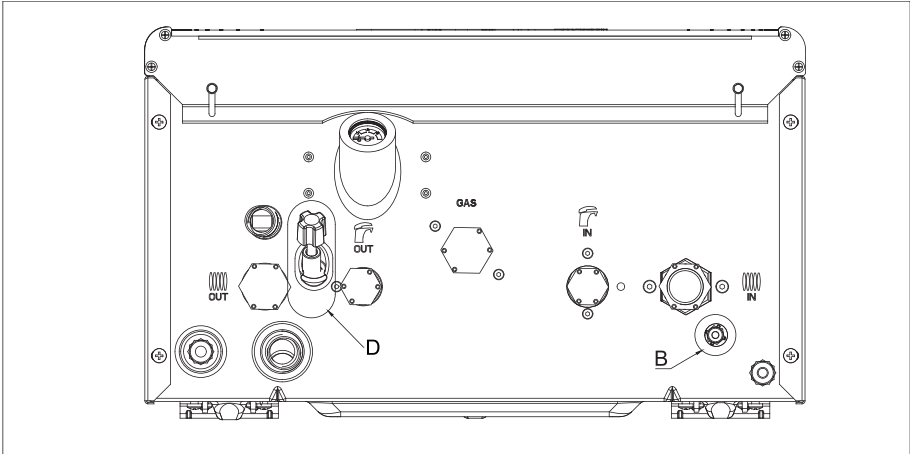

Figure 3. Smart Fit combi boiler bottom view

If the water pressure exceeds 3 bar, drain the required amount of water into a bucket using the drain tap (B) (Figure 3).

Keeping the water pressure in the range of 1-3 bar (indicated in green on the manometer) is necessary for the safe operation of the combi boiler.

ATTENTION!

The pressure of the heater system rises due to the heated water. Loading the system with 2.3-2.4 bar cold water can lead to high water pressure when the heater system heats up. To avoid this, always make sure that your system pressure is 1.2 bar when the water is cold (room temperature or lower).

2.7. Operating Positions and Starting The Combi

Boiler “OFF” Position

In this position the combi boiler is switched off and does not operate in case of any need for any domestic water or heater water. However, the pump jam protection and frost protection functions operate to protect the combi boiler from unsafe conditions.

“SUMMER” Position

To operate your combi boiler in the “SUMMER” position, touch the button (1) (Figure 1) and see that only the tap symbol (F) lights up continuously on the display. In this position, the combi boiler will only operate for the domestic water system. The automatic ignition system will ignite the burner whenever domestic water is needed. The flame formation in the combustion chamber is indicated by (flame) symbol on the display. When using domestic water, the tap symbol (F) on the display flashes.

“WINTER” Position

To operate your combi boiler in the “WINTER” position, touch the button (1) (Figure 1) and see that the symbols of the tap (🚰) and radiator (🔥) light up continuously on the display. In this position, the combi boiler will work for domestic water and heater systems. The automatic ignition system will ignite the burner whenever domestic water or heating is needed. The flame formation in the combustion chamber is indicated by (🔥) symbol on the display. On the display; the tap symbol (🚰), flashes when using domestic water, and the radiator symbol (🔥) flashes when the heater water is needed.

“HEATING ONLY” Position

To operate your combi boiler in the “HEATING ONLY” position, press button (1) (Figure 1) and see that only the radiator (🔥) symbol lights up continuously on the display.

In this position, the combi boiler will operate for the heater system. The automatic ignition system will ignite the burner whenever heating is needed. The flame formation in the combustion chamber is indicated by (🔥) symbol on the display. The radiator symbol (🔥) flashes on the display when the heating is needed.

ATTENTION!

If there is no room thermostat in the system (bridged), the pump circulates continuously in the “WINTER” and “HEATING ONLY” positions, so the radiator symbol flashes continuously.

Starting The Combi Boiler

- Make sure that the gas path to the device is open and that there is a gas inlet to the device.
- When the device is energized, “OFF” will be displayed on the display. By touching the mode button (1) (Figure 1), you can switch between SUMMER-WINTER-HEATING ONLY-OFF positions, respectively.
- The combi boiler will automatically light up when the “WINTER” or “HEATING ONLY” positions are selected (provided that a room thermostat is connected or the connection is bridged). When “SUMMER” position is selected, a hot water tap should be opened to ignite the combi boiler.
- Check that there are no flashing digits on the display (7) (Figure 1) (see error codes). If the display (7) shows the error E04, this indicates that there is no water in the combi boiler. In this case, fill the system with water as described in “Section 2.6”.

Setting the Heating Temperature

The heating temperature is set by the buttons (3) and (4) (Figure 1).

- The heater set temperature is decreased by touching the button (3).
- The heater set temperature is increased by touching the button (4).
- The heater set temperature is increased or decreased by sliding the button (10).

The set temperature for the heater water is determined as minimum 30°C and maximum 85°C. If operating at low temperature (e.g. underfloor heating system), these temperatures are minimum 25°C and maximum 50°C.

If the button (3) or (4) is pressed once when the display light is off, the display turns on and the set temperature appears. After about 5 seconds, the display turns off and the current temperature continues to appear on the display.

Setting Domestic Water Temperature

The domestic water temperature is set by buttons (5) and (6) (Figure 1).

- The hot domestic water set temperature is increased by touching button (5).
- The hot domestic water set temperature is decreased by touching button (6).
- The domestic water set temperature is increased or decreased by sliding the button (11).

The set temperature for the domestic water is determined as minimum 30°C and maximum 60°C.

If button (5) or (6) is touched once when the display light is off, the display illuminates and the set temperature appears. After about 5 seconds, the display turns off and the current temperature continues to appear on the display.

ATTENTION!

The air venting function operates for safe operation when the device is first commissioned and after each power failure. The air venting function lasts about 3 minutes and during this time “PnP run” appears on the display.

2.8. Diagnosis-Error Codes

This section contains a list of error codes that may occur on the combi boiler's display **(7)** (see Figure 1), the relevant symptoms, and the actions the user can take to reset the combi boiler.

 If the problem occurs again after the following procedures have been carried out, call the authorized service.

E01 No Flame or Fake Flame

This error code appears when there is no flame (ionization current) on the burner. In this case, the error message E01 appears on the display.

- Check the gas meter and the gas valve on the combi boiler and make sure that gas is coming from the mains (or that there is gas inside the tank).
- Turn the device off and on again using the button **(8)** (Figure 1) on the control panel. Wait for the system to ignite, if the error E01 appears again, turn the device off and on once again. This is done to ensure that the gas in the pipes reaches the device.
- When the error code on the display disappears, the combi boiler will start again. If the problem persists, call the Authorized Service.

This error is mostly encountered in devices that do not have gas inlet for a long time. In this case, the device starts when the gas is supplied to it and after several ignition attempts.

E02 Limit Thermostat Error

The code E02 is appears constantly on the display. Call the authorized service.

E03 Flue Fuse Failure

The code E03 is appears constantly on the display. Call the authorized service.

E04 Low Water Pressure Error

This error occurs due to low pressure in the heater system.

If the **E04 Low Installation Water Pressure Error** appears continuously on the display;

- Check the water pressure in the heater circuit using the manometer.
- Fill the system with water until the pressure reaches 1.2 bar (Section 2.6).
- The combi boiler will restart automatically. If the problem persists, call the authorized service.

There is no error code for high water pressure error. In such a case, to drain the water from the heater;

1. Close the domestic water inlet valve at the bottom of the device.
2. Open a HOT water tap in the kitchen or bathroom (Prefer the tap closest to the device)
3. Open the filling tap inside the device and check the pressure value with the help of the manometer until it drops to the desired level.
4. When you see the acceptable pressure value on the manometer; turn off the hot water tap and the filling tap inside the device and open the domestic water main inlet valve under the device.

E05 Heater Flowing Water Sensor Failure

The code E05 is appears constantly on the display. Call the authorized service.

E06 Domestic Water Sensor Failure

The code E06 is appears constantly on the display. Call the authorized service.

E16 Fan Failure

The code E16 is appears constantly on the display. Call the authorized service.

E22 Electronic Card Microprocessor Failure

The code E22 is appears constantly on the display. Call the authorized service.

E31 Remote Control Failure

The code E31 is appears constantly on the display. Check the battery and cable of the remote controller. If the problem persists, call the authorized service.

E98 Main Supply Failure

The code E98 is appears constantly on the display. Call the authorized service.

E99 Safety Failure

The code E99 is appears constantly on the display. Call the authorized service.

- - - Main Power Supply Error

- - - appears continuously on the display. Call the authorized service.

NOTE!

If the combi boiler will not be used for a long time, the user must do one of the following:

- If the combi boiler will not be used for a long time in summer (summer holiday, etc.): Unplug the power plug (or turn off the S-automat if present). Close the combi boiler gas supply valve. Close the domestic water mains inlet valve.
- If the combi boiler will not be used for a long time in winter: Leave the combi boiler in standby mode with the electric and gas connected, therefore the frost protection active.

2.9. Automatic Control Devices (Optional)

To ensure comfort and fuel economy at the same time, it is recommended to use one of the following automatic control devices:

a. Room Thermostat

Operates the device according to the desired room temperature. Analog and digital models are available. These models cannot be programmed.

b. Weekly Programmable Room Controller

Operates the device according to the desired room temperature in the desired weekly time periods.

c. Wired / Wireless Remote Control

Operates the device according to the desired room temperature in the desired weekly time periods. All operating positions of the device, boiler and domestic water temperatures can be adjusted and seen, if there is an outdoor sensor connected to the combi boiler, the outdoor temperature can also be seen. In case of failure, the error codes of the combi boiler appear on the display. There are wired or wireless models. When used with telephone control or internet interface devices, combi boilers can be controlled remotely by telephone.

d. Smart Combi Boiler Thermostat Set

You can control your combi boiler from home using your smart thermostat or from anywhere in the world using your smartphone or tablet. You can access and change current temperature settings or time schedules. To do this, you need to download the free app to your telephone or tablet and have a modem at home.

e. Telephone Control Interface Devices

They allow your combi boiler to be easily switched on/off remotely by telephone. There are two models that can work with land line and GSM lines.

f. Outdoor Air Sensor

It operates the device automatically according to the outside weather conditions. It can be used as stand-alone or together with the above controller or thermostats.

All automatic control devices are optional and you can get detailed information from our website (www.alarko-carrier.com.tr) and through your authorized dealer or service.

2.10. Automatic Operation of the Combi Boiler According to Outdoor Temperature (Optional)

When the optional outdoor sensor is connected to the combi boiler, the device can be managed in one of the following two ways:

- If the remote control + outdoor temperature sensor is connected, the remote control will be able to adjust the outdoor air compensation curve (see remote control manual).
- If only the outdoor temperature sensor is connected, the outdoor air compensation curve can be adjusted by the authorized service via the electronic card. Parameter settings should only be made by an authorized service.

When the outdoor air sensor is installed, the heater water flow temperature is adjusted between 30-85°C in systems with radiators depending on the conditions. In underfloor heating systems, this range is between 25-50°C.

NOTE!

The heater water temperature values of the given temperature correspond to the standard 30-85°C or 25-50°C underfloor heating applications. This selection is made by the dealer using parameter P03.

2.11. Solar Connection Kit (Optional)

With the Smart Fit gas burning combi boiler device, it is possible to prepare domestic water much more economically by using solar energy. To achieve this, the solar collector and hot water boiler must be mechanically connected to the solar connection kit (Figure 5) provided as an accessory as shown in Figure 4. No electronic control system is required.

The separator valve in the solar connection set (Figure 5) directs the water from the boiler directly to the mixing valve if the water temperature in the boiler is above 48°C. The thermostatic mixing valve also mixes with cold water and sends the domestic water to the taps at a constant temperature of 40°C, preventing scalding against high temperature. If the water temperature in the combi boilers is below 48°C, the separator valve directs the domestic water to the combi boiler to be heated to the desired temperature. The domestic water coming out of the combi boiler passes through the thermostatic valve again while its temperature is adjusted and reaches the taps. The thermostatic valve can be adjusted between 25-60°C. The solar connection set includes the solar connection body and the pipes as seen in Figure 5.

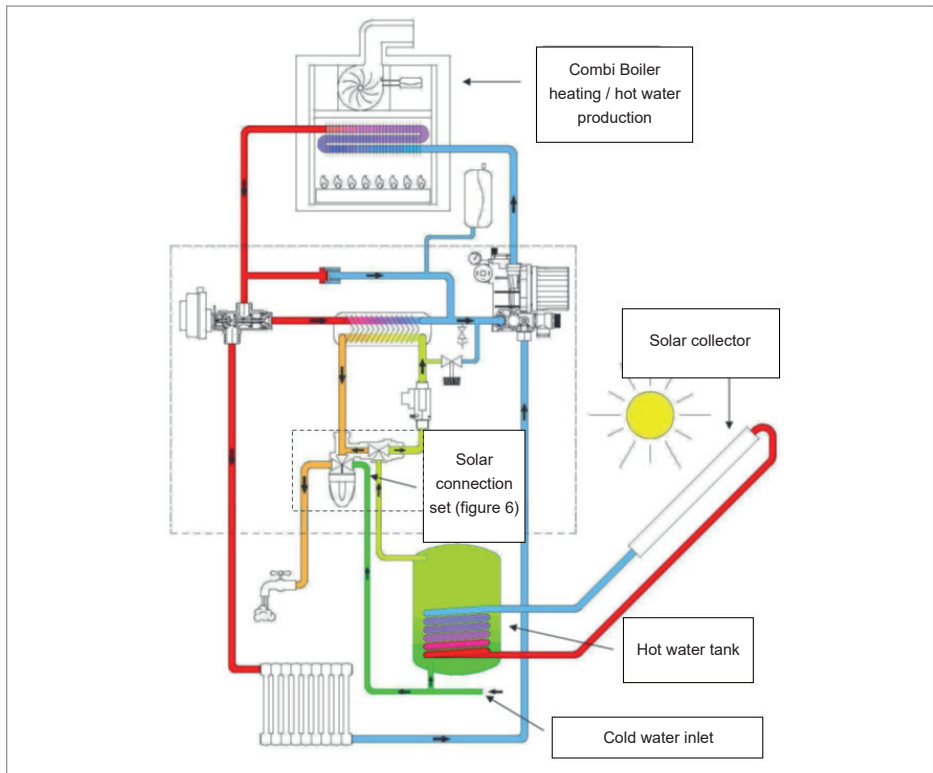
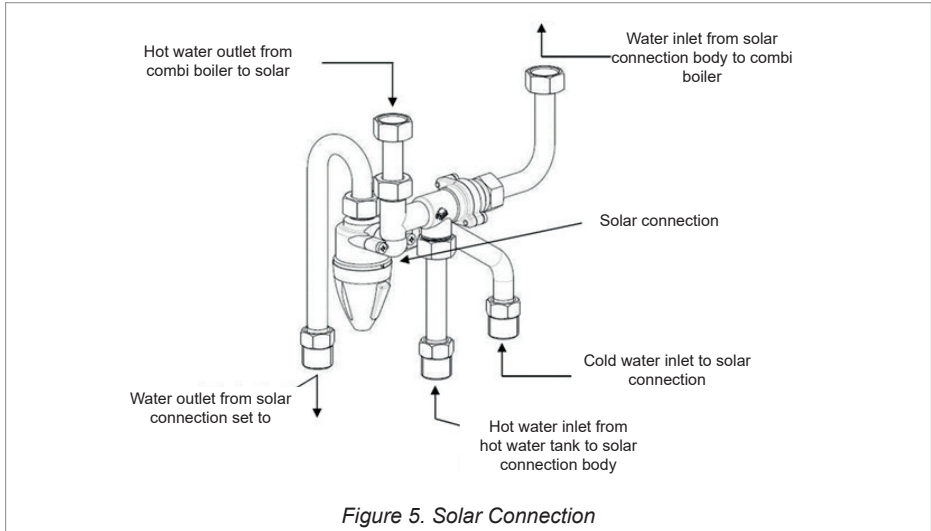

Figure 4. Solar Connection Kit Application



2.12. LPG (Propane) Usage

Your combi boiler can be used with LPG (propane). Your combi boiler should be adjusted by the authorized service according to the use of LPG (propane). The combi boiler is available for operation with at least two LPG (propane) cylinders determined according to the device capacity, provided that they are connected via a “collector kit”. In the case of using thermostatic hot water buckets to heat LPG (propane) tubes, the water temperature should not exceed 22°C.

Do not place LPG (propane) cylinders and combi boiler in the same cabinet. Use only tubes with TSE certificate.

Do not shake the tubes or lay them on the ground.

Use only one certified 30 mbar regulator for each tube outlet.

If you smell gas, close the tubes and follow the instructions in the Gas Safety section.

ATTENTION!

The adjustment of the combi boiler to work with LPG (propane) shall be made by the Authorized Service.

If certified regulators are not used with the combi boiler at the appropriate pressure, the combi boiler will be out of warranty.

3. TECHNICAL SPECIFICATIONS

3.1. Technical Specifications Table

MODEL	UNIT	SMART FIT		
		SMF 25	SMF 30	SMF 35
CE Certificate		1312DL6438		
Device Category		I2H/3P		
Heating Technical Specifications				
Seasonal Room Heating Energy Efficiency Class		A	A	A
Seasonal Room Heating Energy Efficiency (hs)	%	91.13	92.21	90.71
Efficiency at 30% Partial Load (h1) (50-30°C)	%	96.93	97.96	96.35
Efficiency at Maximum Capacity (h4) (80-60°C)	%	87.59	87.77	87.70
Rated Heat Power (Prated) (80-60°C)	kW	22	26	32
Maximum Heating Capacity (P4) (80-60°C)	kW	22.1	25.6	32.1
Minimum Heating Capacity (80-60°C)	kW	4.9	6.1	7.7
Maximum Heating Capacity (50-30°C)	kW	24.3	28.1	34.9
Heating Capacity at 30% Partial Load (P1) (50-30°C)	kW	7.33	8.551	10.59
Minimum Heating Capacity (50-30°C)	kW	5.4	6.9	8.3
Auxiliary Electricity Consumption at Full Load (elmax) (80-60°C)	kW	0.079	0.086	0.114
Auxiliary Electricity Consumption at Partial Load (slmCj) (80-60°C)	kW	0.036	0.035	0.053
Annual Energy Consumption (QHE)	GJ	42	50	63
Heating Temperature Setting Range (Min. - Max.)	°C	30 - 85 (Radiator Heating) / 25 - 50 (Underfloor Heating)		
Heating Working Pressure (Min. - Max.)	bar	0.5 - 3		
Hot Water Technical Specifications				
Water Heating Energy Efficiency Class		A	A	A
Water Heating Energy Efficiency (hWH)	%	86	86	85
Water Heating Load Profile		XL	XL	XL
Hot Water Flow Rate at AT:30K	liter/min	13	14	16
Max. Hot Water Flow Rate	liter/min	14	18	18
Daily Electricity Consumption (Qelec)	kWh	0.186	0.181	0.19
Annual Electricity Consumption (AEC)	kWh	41	40	42
Daily Fuel Consumption (Qfuel)	kWh	22.838	23	22.442
Annual Fuel Consumption (AFC)	GJ	18	18	18
DHWr Temperature Setting Range (A4/n. - Max.)	°C	30 - 60		
DHWr operating Pressure (Min. - Max.)	bar	0.5 - 10		
General Technical Specifications				
NOx Class		6	6	6
Nitrogen Emission (NOx)	mg/kWh	37.05	46.03	43.18
Sound Power Level, Indoor (LWA)	dB	54	54	57
Auxiliary Electrical Consumption in Standby (PSB)	kW	0.004	0.004	0.004
Heat Loss During Standby (Pstby)	kW	0.063	0.066	0.073
Ignition Burner Energy Consumption (Pign)	kW	5.51	5.24	7.33
Flue Gas Temperature (50-30°C, Min. - Max.)	°C	45-52	46-53	45-61
Flue Gas Temperature (80-60°C, Maks.)	°C	71.6	70.8	72.5
Gas Consumption (Natural Gas - LPG)	m ³ /h - kg/h	2.3 - 1.7	2.7 - 2.0	3.3 - 2.3
Electricity Consumption	W	82	84	117
Physical Properties				
Flue Type		B23-B33-C13-C13(x)-C33-C33(x)-C43-C43(x)-C53- C53(x)-C63-C63(x)-C83-C83(x)-C93-C93(x)		
Standard Horizontal Concentric Flue System - Max. Length	Ø - m	60/100 - 8		
Vertical Concentric Flue System - Max. Length	Ø - m	60/100 - 8		
Twin Flue System - Max. Length	Ø - m	80+80 - 50		
Size (Width x Height x Depth)	mm	437 x 642 x 259		
Weight (Net)	kg	28.9	30.8	32
Expansion Tank Capacity	liters	8		
Heater Outlet - Inlet Diameter	Ø	3/4"		
Cold Water Inlet - Hot Water Outlet Diameter	Ø	1/2"		
Gas Inlet Diameter	Ø	3/4"		
Gas Inlet Pressure (Natural Gas - LPG)	mbar	20 - 30		
Power Source	V/Hz	230/50		
Protection Class	IP	X4D		

3.2. Product Fiche

The product data presented below comply with the requirements of EU regulations 811/2013 and 813/2013.

Model		SMF 25	SMF 30	SMF 35
Space heating - Temperature application		Medium	Medium	Medium
Water heating - Rated load profile		XL	XL	XL
Seasonal space heating energy efficiency class		A	A	A
Water heating energy efficiency class		A	A	A
Rated heating power	kW	22	26	32
Space heating - Annual energy consumption	GJ	42	50	63
Water heating - Annual fuel consumption	GJ	18	18	18
Water heatin - Annual electricity consumption	kWh	41	40	42
Seasonal space heating energy efficiency	%	91	92	91
Water heating energy efficiency	%	86	86	85
Sound power level Lwa, indoor	dB	54	54	57

3.3. Technical Parameters

The product data presented below comply with the requirements of EU regulations 811/2013 and 813/2013.

Model:				SMF25			
Condensing Boiler:				Yes			
Low Temperature (+) Boiler:				No			
Bil Boiler:				No			
Cogeneration Room Heater:				No			
Combined Heater:				Yes			
				If yes, is there any additional heater?			
				No			
Item	Symbol	Value	Unit	Item	Symbol	Value	Unit
Nominal heat power	P_{rated}	22.1	kW	seasonal space heating energy efficiency	η_s	91.13	%
				Energy efficiency class		A	
For space heating combi boilers and combined heater combi boilers: Useful heat capacity output				For space heater combi boilers and combined heater combi boilers: Useful efficiency			
At maximum capacity and high temperature operation (*)	P_4	22.1	kW	At maximum capacity and high temperature operation (*)	η_4	87.6	%
At 30% of maximum capacity and low temperature operation (**)	P_1	7.3	kW	At 30% of maximum capacity and low temperature operation (**)	η_1	96.93	%
Auxiliary electricity consumption				Other items			
At full load	e_{load}	0.079	W	Heat loss during standby	P_{shy}	0.063	
At partial load	e_{min}	0.036	W	Ignition burner power consumption	P_{on}	5.51	kw
In standby state	P_{SB}	0.004	W	Annual energy consumption	Q_{aE}	42	kWh
				Sound power level, indoor	L_{wa}	54	dB
				No _x emissions	NO_x	37.05	mg/kWh
For combined heaters:							
Rated load profile	XL			Water heating energy efficiency	η_{WH}	85.9	%
Daily electricity consumption	Q_{aEC}	0.188	kWh	efficiency class		A	
Annual electricity consumption	AEC	41.370	kWh	Daily fuel consumption	Q_{aFC}	22.510	kWh
Contact Information	ALARKO CARRIER SAN. TC. A.Ş. GOSB - Gebze O.Ş.B., Şahabettin Bilgişu Cad., 41400, Gebze/Kocaeli/Turkey			Annual fuel consumption	AFC	17.828	GJ
(*) High temperature operation: There should be 60°C return temperature at the heater inlet and 80°C supply water temperature at the heater outlet.							
(**) Low temperature operation: The return water (at the heater inlet) temperature should be 30°C for condensing boilers, 31°C for low temperature boilers and 50°C for other heaters.							

Model:				SMF30			
Condensing Boiler:				Yes			
Low Temperature Boiler:				No			
Bil Boiler:				No			
Cogeneration Room Heater:				No			
Combined Heater:				Yes			
If yes, is there any additional heater?				No			
Item	Symbol	Value	Unit	Item	Symbol	Value	Unit
Nominal heat power	P_{rated}	25.5	kW	Seasonal room heating energy efficiency	η_s	92.2	%
				Energy efficiency class		A	
<i>For space heating combi boilers and combined heater combi boilers: Useful heat capacity output</i>				<i>For space heater combi boilers and combined heater combi boilers: Useful efficiency</i>			
At maximum capacity and high temperature operation (*)	P_d	25.5	kW	At maximum capacity and high temperature operation (*)	η_d	87.8	%
At 30% of maximum capacity and low temperature operation (**)	P_l	8.6	kW	At 30% of maximum capacity and low temperature operation (**)	η_l	97.9	%
<i>Auxiliary electricity consumption</i>				<i>Other items</i>			
At full load	e_{load}	0.066	W	Heat loss during standby	P_{std}	0.066	kW
At partial load	e_{part}	0.035	w	Ignition burner power consumption	P_{ign}	5.24	kWh
In standby state	P_{sb}	0.004	w	Annual energy consumption	Q_{HE}	50	kWh
				Sound power level, indoor	L_{WA}	54	dB
				No, emissions	NO_x	46.03	mg/kWh
For combined heaters:							
Rated load profile	XL			Water heating energy efficiency	η_{WH}	85.7A	%
Daily electricity consumption	Q_{elec}	0.181	kWh	Daily fuel consumption	Q_{fuel}	22.619	kWh
Annual electricity consumption	AEC	39.828	kWh	Annual fuel consumption	AFC	17.915	GJ
Contact Information	ALARKO CARRIER SAN. TC. A.Ş., GOSB - Gebze O.S.B., Şahabettin Bilgisi Cad., 41400, Gebze/Kocaeli/Turkey						
*) High temperature operation: There should be 60°C return temperature at the heater inlet and 80°C supply water temperature at the heater outlet.							
(**) Low temperature operation: The return water (at the heater inlet) temperature should be 30°C for condensing boilers, 31°C for low temperature boilers and 50°C for other heaters.							

Model:				SMF35			
Condensing Boiler:				Yes			
Low Temperature (**) Boiler:				No			
Bil Boiler:				No			
Cogeneration Room Heater:				No			
Combined Heater:				Yes			
If yes, is there any additional heater?				No			
Item	Symbol	Value	Unit	Item	Symbol	Value	Unit
Nominal heat power	P_{rated}	32.1	kW	Seasonal space heating energy efficiency	η_s	91.0	%
				Energy efficiency class		A	
<i>For space heater combi boilers and combined heater combi boilers: Useful heat capacity output</i>				<i>For space heater combi boilers and combined heater combi boilers: Useful efficiency</i>			
At maximum capacity and high temperature operation (*)	P_d	32.1	kW	At maximum capacity and high temperature operation (*)	η_d	87.7	%
At 30% of maximum capacity and low temperature operation (**)	P_l	10.6	kW	At 30% of maximum capacity and low temperature operation (**)	η_l	96	%
<i>Auxiliary electricity consumption</i>				<i>Other items</i>			
At full load	e_{load}	0.114	W	Heat loss during standby	P_{std}	0.073	kW
At partial load	e_{part}	0.053	W	Ignition burner power consumption	P_{ign}	7.33	kWh
In standby state	P_{sb}	0.004	W	Annual energy consumption	Q_{HE}	63	kWh
				Sound power level, indoor	L_{WA}	57	dB
				No, emissions	NO_x	43.181	mg/kWh
For combined heaters:							
Rated load profile	XL			Water heating energy efficiency	η_{WH}	85.2	%
Daily electricity consumption	Q_{elec}	0.189	kWh	Daily fuel consumption	Q_{fuel}	22.770	kWh
Annual electricity consumption	AEC	41.631	kWh	Annual fuel consumption	AFC	18.034	GJ
Contact Information	ALARKO CARRIER SAN. TC. A.Ş., GOSB - Gebze O.S.B., Şahabettin Bilgisi Cad., 41400, Gebze/Kocaeli/Turkey						
*) High temperature operation: There should be 60°C return temperature at the heater inlet and 80°C supply water temperature at the heater outlet.							
(**) Low temperature operation: The return water (at the heater inlet) temperature should be 30°C for condensing boilers, 31°C for low temperature boilers and 50°C for other heaters.							

3.4. Dimensions

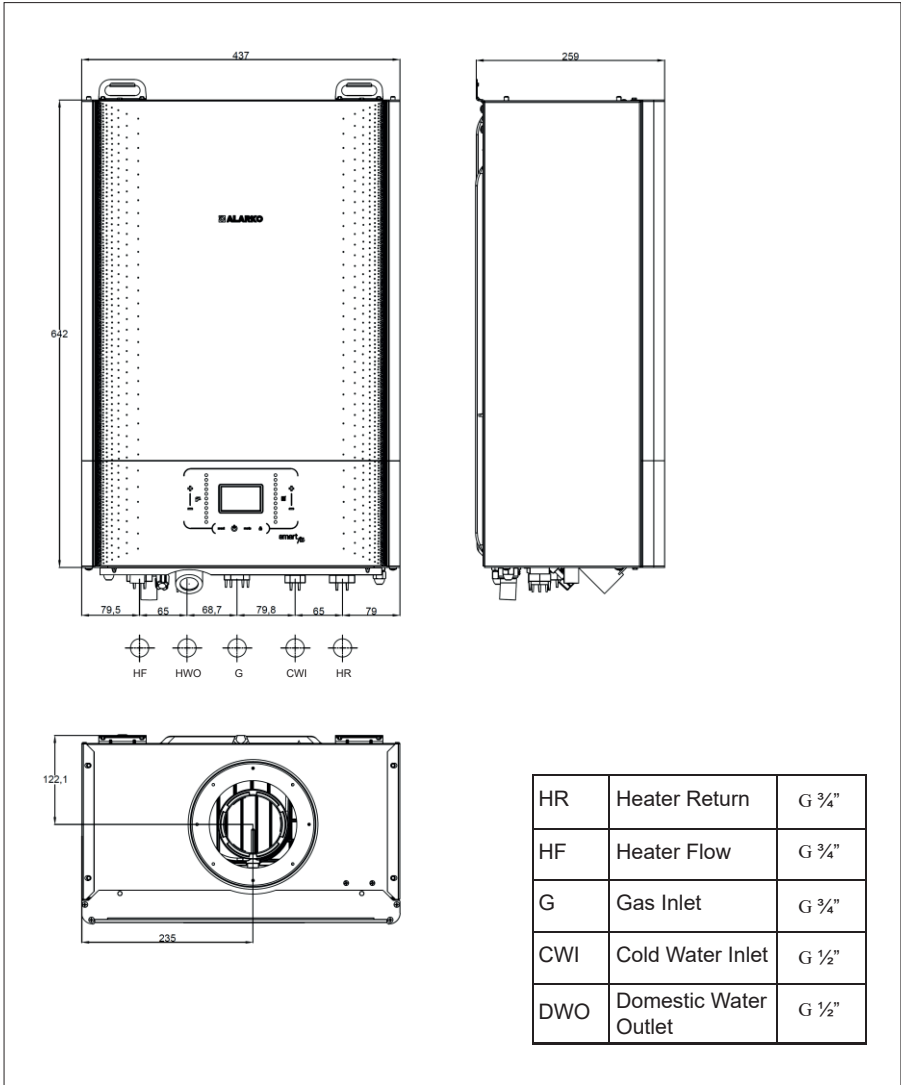

Figure 6. Dimensions

3.5. Main Parts of the Combi Boiler

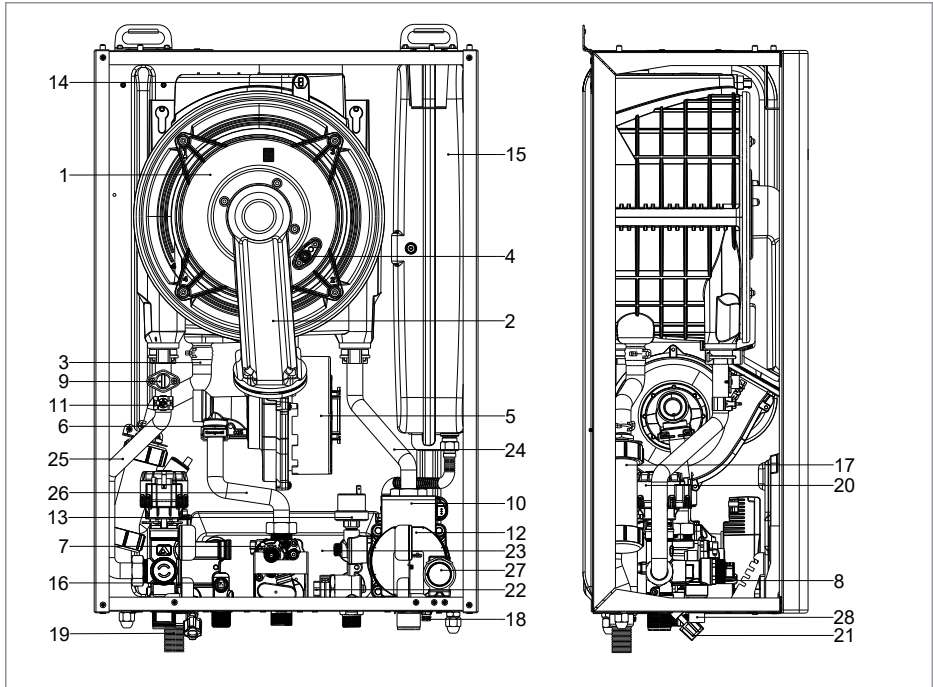

Figure 7. Main Parts

- | | |
|---|---------------------------------------|
| 1. Condensing main exchanger | 15. Expansion tank |
| 2. Premix burner unit (gas manifold + burner) | 16. Domestic water temperature sensor |
| 3. Siphon inlet hose | 17. Siphon |
| 4. Ionization and ignition electrode | 18. Drain tap |
| 5. Fan | 19. Condensation drain pipe |
| 6. Venturi | 20. 3-way valve motor |
| 7. Electronic gas valve | 21. Filling tap |
| 8. 3 bar safety valve | 22. Electronic flow sensor |
| 9. Limit thermostat | 23. Domestic water exchanger |
| 10. Automatic air discharge valve | 24. Heater return pipe |
| 11. Pump | 25. Heater inlet pipe |
| 12. Heater flowing water sensor | 26. Gas inlet pipe |
| 13. Pressure switch | 27. Manometer |
| 14. Flue fuse | 28. Plastic drain connection |

3.6. Water Circuit

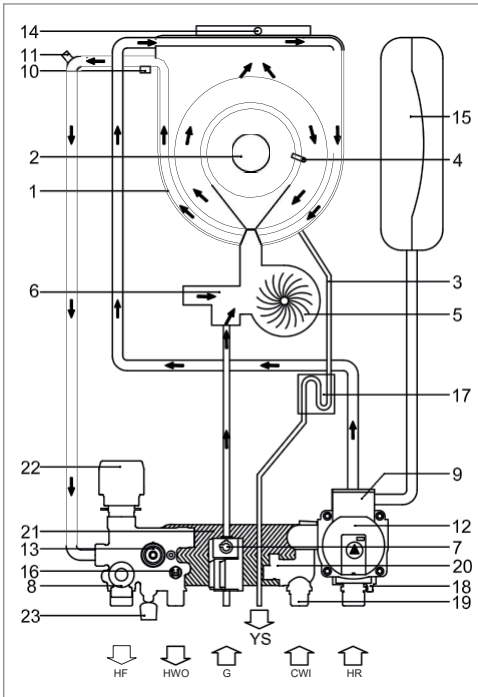

Figure 8. Schematic representation of the water circuit

1. Condensing main exchanger
2. Premix burner unit (gas manifold + burner)
3. Condensation drain pipe
4. Ionization and ignition electrode
5. Fan
6. Venturi
7. Electronic gas valve
8. 3 bar safety valve
9. Automatic air discharge valve
10. Limit thermostat
11. Heater flowing water sensor
12. Pump
13. Pressure switch
14. Flue fuse
15. Expansion tank
16. Domestic water temperature sensor
17. Siphon
18. Drain tap
19. Flow limiter
20. Electronic flow sensor
21. Domestic water exchanger
22. 3-way valve motor
23. Water filling tap

HR	HEATER RETURN
HF	HEATER FLOW
G	GAS INLET
CWI	COLD WATER INLET
HWO	HOT WATER OUTLET
CD	CONDENSATE OUTLET

3.7. Circulation Pump

ErP-compliant ($EEL \leq 0.23$) and highly efficient circulation pump with integrated differential pressure adjustment is used in Smart Fit gas burning combi boiler devices. The mode of operation and the pump head (differential pressure) can be adjusted. The EEI value of the modulated pump used is ≤ 0.20 .

Circulation Pump Performance Graph

SMF 25/30

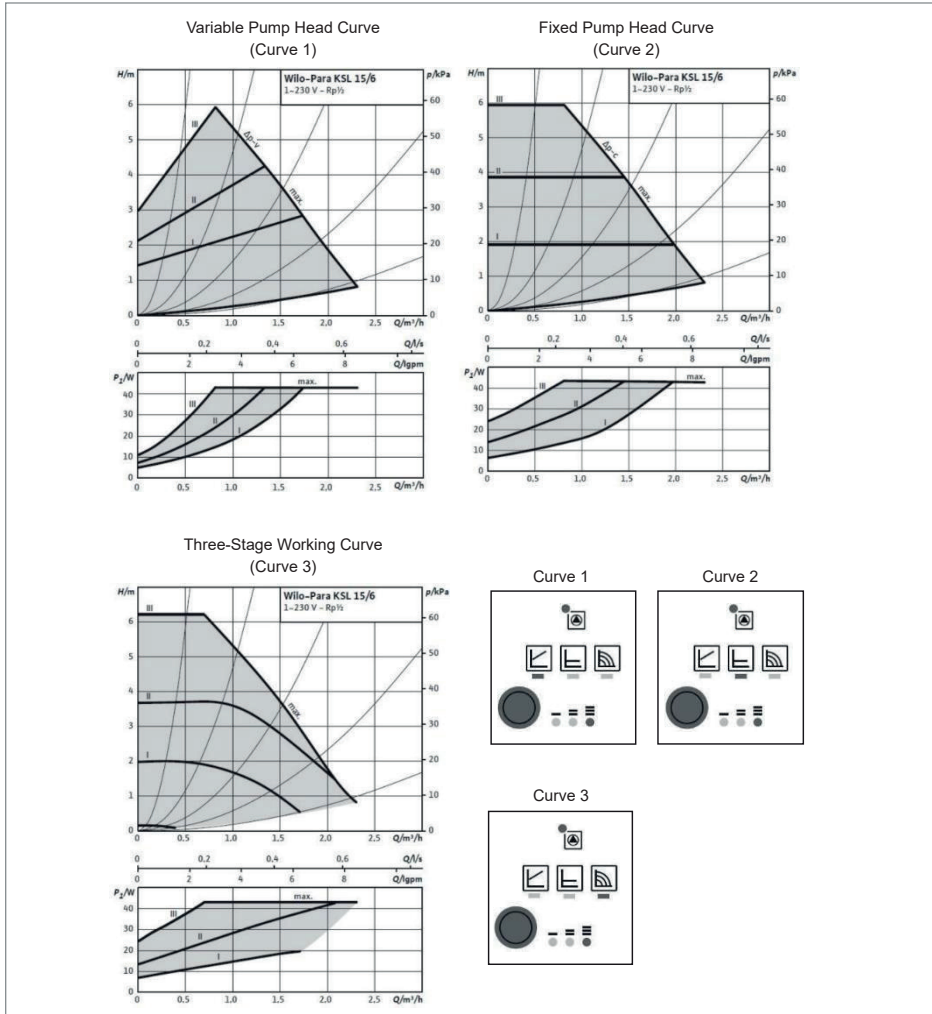

Figure 9. SMF 25/30 Pump performance curve

SMF 35

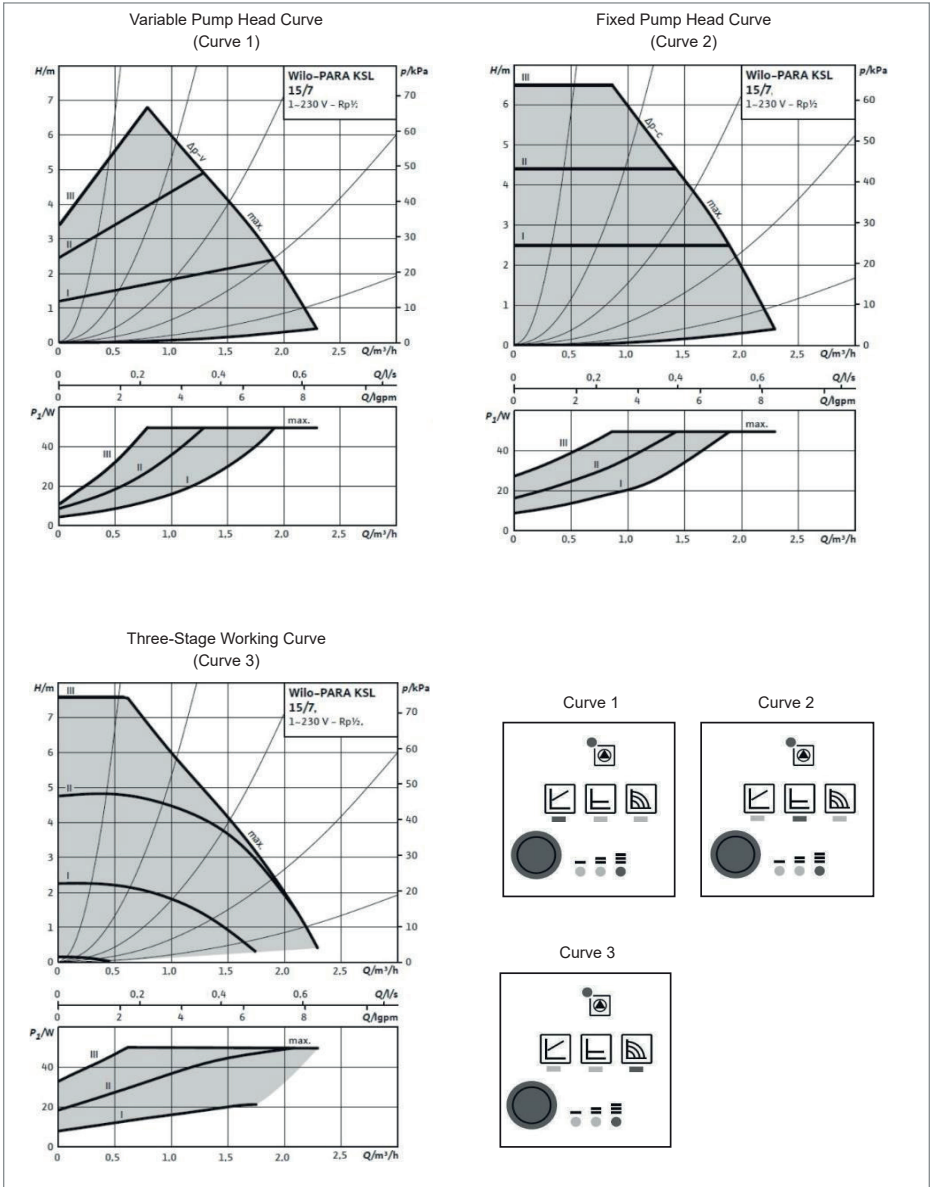

Figure 10. SMF 35 Pump performance curve

3.8. Electronic Ignition and Control Board - MIAB

3017 Basic Characteristics

The following interventions requiring adjustment/selection shall only be performed by authorized service personnel.

- Parameters programming function
- Continuous flame modulation during heater and domestic water cycles
- Suitable for both radiator and underfloor heating systems with standard (30/85°C) / reduced (25/50°C) heating temperature selection
- Automatic operation function according to outdoor temperature (when using optional outdoor air sensor)
- Initial power ramp time setting in the heater cycle
- Pump overrun time setting in heater and domestic water cycles (Heater, heater freeze protection, domestic water, domestic water freeze protection, and flue sweep cycles are active)
- Heater and domestic water freeze protection function
- Flue sweeping function
- Alternative pump controls
- Pump jam prevention function
- 3-way valve jam prevention function
- Remote controller communication network (opentherm protocol)
- 11-key matrix touch user interface
- Failure notification with error codes
- Optional remote control devices for heater water system
 - Room thermostat
 - Remote controller communication network (opentherm protocol)
- Water pressure switch
- Limit thermostat
- Flue fuse
- Temperature sensor integrity check
- Fan speed control
- Automatic flame control system
- Demo mode (for display in exhibition halls)

User settings

- Summer / Winter / Heating Only / Off
- Heating temperature setting (standard 30-85°C or reduced 25-50°C)
- Domestic water temperature setting (between 30-60°C)

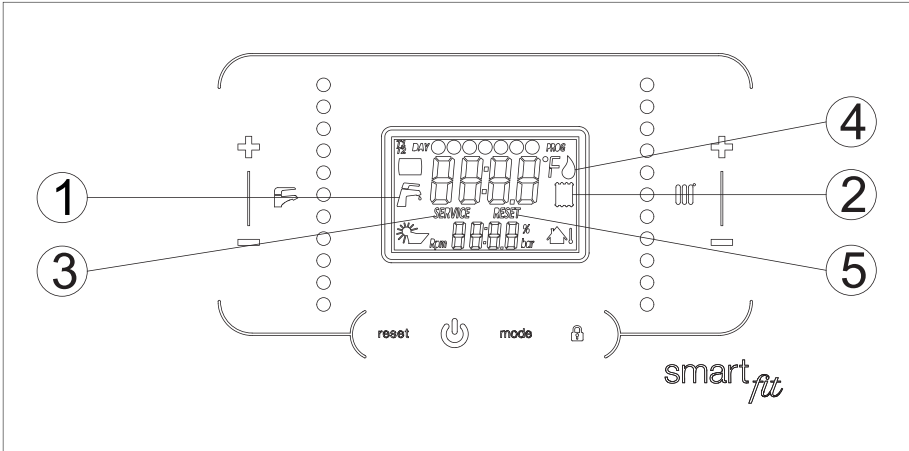

Figure 11. Display

Display Basic Symbols

Icon 1: Domestic water is being heated (Flashes when domestic water is on)

Icon 2: Heater installation water is being heated (Flashes when heater installation is being heated and the pump is running)

Icon 3: Turns on when parameter and service info menu is opened

Icon 4: Turns on in the presence of flame

Icon 5: Reset

ATTENTION!

When the combi boiler is switched off from the control panel, the word OFF appears in the display. The domestic water and heating frost protection system still remains active. If the combi boiler was in the open position, it is closed and after fan sweeping, the pump overrun, the circulation pump and the 3-way valve inertia protection system are activated.

The remote control, if any, remains active and illuminated.

4. ASSEMBLY INSTRUCTIONS

4.1. Relevant Standards

This device is manufactured in accordance with the following norms and directives:

- 15502-1:2021 Gas-fired heating boilers – Part 1: general rules and experiments
- 15502-2-1:2022 Gas-fired heating boilers – Part 2-1: specific standards for type c devices and devices of types b2, b3, and b5 whose rated heat input does not exceed 1,000 kw
- TS EN 60335-1: Safety rules - for electrical devices used at home and similar places - Section 1: general rules
- TS EN 60335-2-102: Safety rules - for electrical devices used at home and similar places - Section 2-102: special rules for devices burning gas, oil, and solid fuels with electrical connections
- EN 13203-2 Gas-burning hot domestic water generating devices - Section 2: energy consumption assessment.
- IPX4D Classification for Electrical Devices
- 2016/426/EU: Regulation On Gas Burning Devices
- 811/2013: Energy labeling of room heaters and combi boiler heaters
- 813/2013: Eco-design requirements for room heaters and combi boiler heaters
- 2014/35/EU: Low Voltage Directive

Electromagnetic compatibility (EMC) tests of combi boilers were carried out according to the following standards:

- EN 55014-1: Electromagnetic compatibility - Specifications for electrical devices and similar devices used at home and similar places - Section 1: Emission
- EN 55014-2: Electromagnetic compatibility- Requirements for appliances, electrical devices, and similar devices used at home and similar places - Section 2: Immunity - Product family standard
- EN 61000-3-2: Electromagnetic compatibility (EMC) - Section 3-2: Limits - Limits for harmonic current emissions (hardware carrying ≤ 16 A input current per phase)
- EN 61000-3-3 (2013): Section 3-3: Limits - Restriction on voltage changes, voltage fluctuations, and flicker in general low voltage supply systems for equipment with rated current per phase ≤ 16 A and not subject to conditional connection.

According to the relevant regulations, all gas-powered devices must be assembled by authorized persons in accordance with the rules and regulations.

The manufacturer's instructions in no case supersede the legal obligations.

In addition to the instructions in this book, the installation and the components used must also comply with the standards in order for the installation to be carried out

in accordance with the standards.

4.2. Device Location

The specifications of the local gas administration and national standards should be taken into account in the device location.

4.3. Transportation and Packaging

The combi boiler is in a cardboard package. The markings on the packaging must be observed during handling and storage.

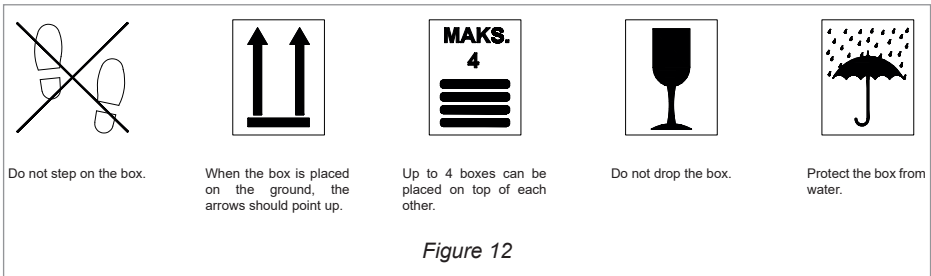

- The combi boiler can be transported by two people lifting from the holes on the sides.
- The combi boiler must be stored in a dust-free and moisture-free place and must not be unpacked until assembly.
- A maximum of four packaged combi boilers can be placed on top of each other during storage.
- The combi boiler can be assembled after the completion of the electrical and water systems.

Unpacking

1.

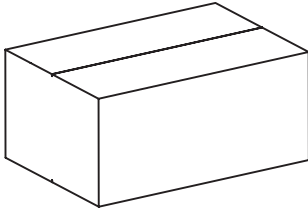

Place the box on the ground with the symbol on top.

2.

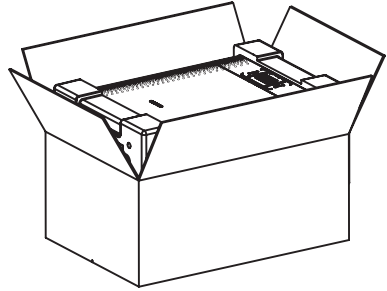

Open the box by cutting the packing tapes.

3.

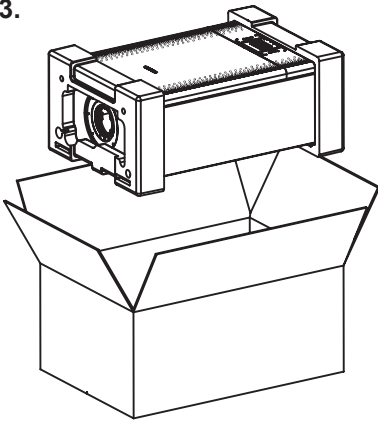

Remove the device from the carton packaging with the nylon packaging.

4.

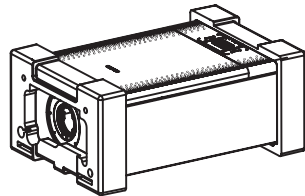

Remove the protective styrofoam after removing the device from the nylon packaging.

DON'T TRY TO REMOVE IT BY KEEPING IT OUT!

Figure 13. Packaging

4.4. Assembling the Device

- The device must be assembled on a flat, sturdy wall that can bear its weight.
- The device must be assembled in closed areas under normal conditions. However, it can also be operated in a suitable cabinet in places such as garage, open balcony, etc. Consult Alarko Carrier for the appropriate cabinet size.
- If the device is located in a non-heated area, it must be connected to electricity and the switch must be on in order for the frost protection to be active. The frost protection remains active even if the device is in the OFF position.
- The device may be assembled in bathroom according to national standards and the specifications of the local gas administrations. The minimum distances specified in Figure 14 must be observed for assembly and service.

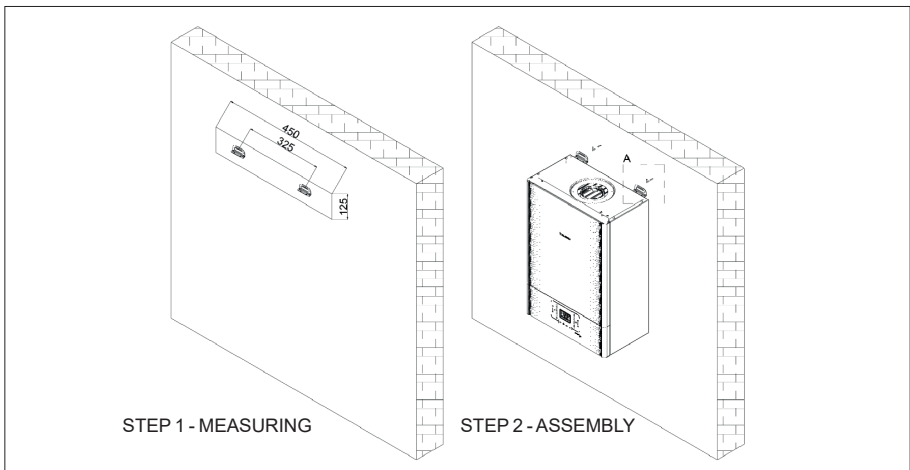
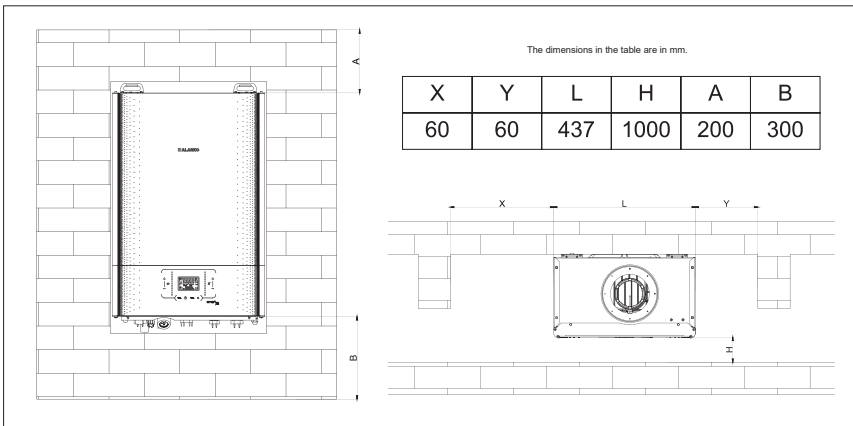
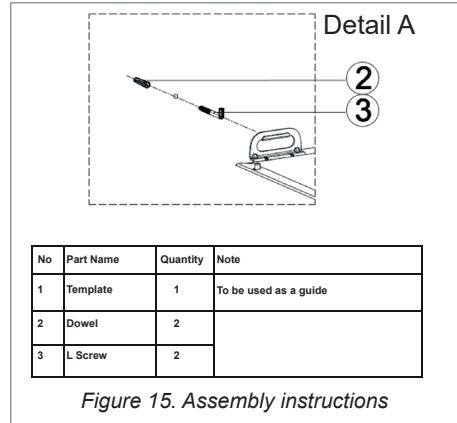

Figure 14. Minimum assembly distances

To assemble the device, the following instructions must be followed (Figure 15). Determine the assembly position by considering the flue position and the necessary service and intervention gaps. First, determine the assembly points on the wall using the assembly template and the spirit level that are supplied (Figure 15 - Step 1). Install the L screws from these points with dowels. Then hang your combi boiler on the L screws (Figure 15 – Step 2).



4.5. Water Connections

- ⚠ In order to protect the exchanger and the water pump, it is recommended that the system be flushed with hot water to remove residues and dirt (especially oil and grease) from the pipes and radiators.
 - ⚠ Ensure that domestic hot water and heating pipes are not used to ground the electrical system. The pipes are definitely not suitable for this purpose.
 - ⚠ It is mandatory to install a ball valve at the domestic water cold water inlet, heater water outlet and return, to install a strainer at the heater water return and domestic water inlet.
 - ⚠ The union at the bottom of the pump (union in Figure 16-A detail) should be tightened with a maximum torque of 18 Nm if rubber gaskets are used, and with a maximum torque of 30 Nm if klingerit gaskets are used.
- To prevent vibration and noise from the system, do not use small diameter pipes and sharp elbows or make serious reductions in water flow sections.

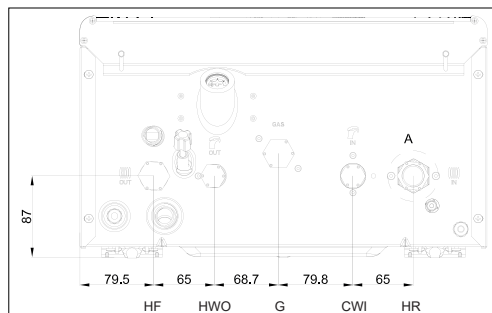

Figure 16. Water Connections

Domestic water circuit

- In order to prevent possible damages such as sediment, etc. in the domestic water exchanger, the tap water should be of at least 17.5 French hardness. Before assembly, it is necessary to check the water hardness and, if necessary, install a suitable water treatment system.

ATTENTION!

The inlet water pressure should be between 0.5-10 bar.

In places with higher pressure, a pressure reducing valve must be placed before the combi boiler.

The cleaning frequency of the plate heat exchanger depends on the hardness of the tap water and the presence of sediment and debris, which is the case in new installations. If the tap water requires treatment, then a suitable treatment system should be installed and a strainer filter should be used against dirt and sediments.

All domestic water circuits, connections, fittings, etc. should be installed in accordance with the standards.

Heating circuit

In order to prevent possible damages such as sediment, etc. in the main exchanger, tap water should be used in the heating circuit, and a purifier should be installed. The use of purifier is mandatory if the system is frequently supplied with water or if system water is frequently discharged (partially or completely).

The output of the combi boiler safety valve must be connected to a drain. Discharging excess water from the safety valve due to excessive system pressure is normal for device safety. The manufacturer is not responsible for floods, etc. that may occur due to the safety valve not being connected to a drain.

Condensate Drainage

The condensate drain pipe supplied with the device is connected to the siphon. It is permitted to discharge the condensate to the drainage system through a siphon. The condensate drainage pipe should be made in the form of an open connection so that there is no interruption in the flow and all horizontal hose connections should be inclined 3° downwards in order to ensure good flow. In order to prevent possible odors, the siphon should be filled with water and if possible, connected to a separate line with a plastic pipe with a diameter of at least 32 mm, and if not possible, to the wastewater drain. (Figure 17)

Condensate drainage pipes passing outside the building or through unheated areas must be insulated against the risk of freezing. There may be a risk of freezing if the condensate is connected to the rainwater drainage pipes.

Maintenance is recommended before every winter. During service and annual maintenance, it must be ensured that the siphon is filled with water and sealed. The suitability of the condensate drain must be checked before starting the combi boiler.

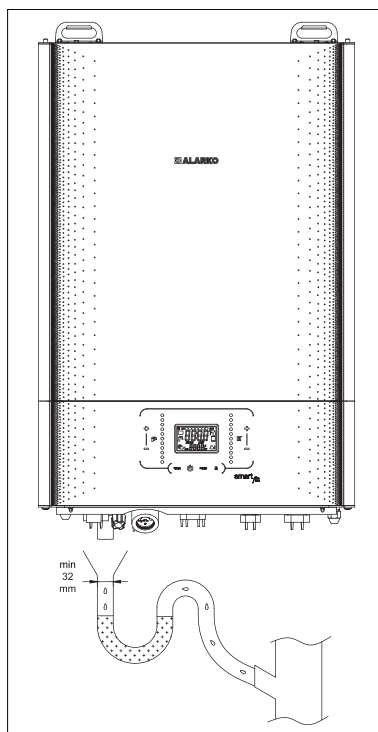

Figure 17. Connection to Drainage Pipe and Wastewater Drainage

4.6. Suitable Heating Installation Pipes

It is highly recommended to use oxygen barrier pipe in accordance with DIN 4726 (with oxygen permeability less than 0.1g/m³/day at 40°C) so that condensing combi boilers are not affected by electro battery, installation sludge, and biocide (green bacteria formed in water).

ATTENTION!

Not every sheathed underfloor heating pipe has an oxygen barrier.

Plastic Tubular Installations Without Oxygen Barrier

- This is not recommended to use.
- Since oxygen will be absorbed into the installation if used, installation sludge may occur in the combi boiler and installation, this will cause the exchanger to clog, and since the characteristics of the water (especially the pH value)

may change, it may lead to the formation of an electro battery (battery effect) and thus to the perforation of the heat exchanger.

- In order to avoid this, the necessary precautions should be taken by adding an inhibitor (additive) (Sentinel X100, etc.).



Underfloor Heating Installations Without Oxygen Barrier

- This is not recommended to use.
- If used, oxygen will be absorbed into the underfloor heating installation operating at low temperature, green biocide bacteria will grow in water at low water temperature, accumulate as a colony, and cause heat exchanger and pump to block by changing the characteristics of the installation water and increasing its viscosity.
- To avoid this, Biocide and anti-electric battery inhibitor addition (Sentinel X 700 + X100, etc.) should be used in the installation.

Installation Blockages

- Generally, in old installations with iron pipes, blockages are encountered shortly after the initial commissioning of the device.
- In case of installation blockage, an inhibitor (Sentinel X400, etc.) should be added to the installation water.

4.7. Gas Connections

-  Connection to the gas source must be carried out by registered, professionally qualified personnel in accordance with existing laws.
-  When connecting the combi boiler to the gas supply pipe, use only gas fittings that comply with the Gas Safety and Use Regulations.



Before assembling the combi boiler, check the following:

- The pipes must have a section suitable for the desired flow rate and length, and the pipes must be installed with all safety and control devices provided with the current standards.
- The gas supply line must be a gas pipe between the meter and the combi boiler, in accordance with the existing standards and rules, which ensure an uninterrupted supply.
- Check the internal and external seals of the gas supply system.
- A cut-off valve must be installed in the gas inlet.
- Before starting the combi boiler, make sure that the type of gas corresponds to the type of gas for which the device is set.
- The gas supply pressure must be between the values indicated on the use

values plate. (refer to the gas type label inside the combi boiler).

- Before assembly, make sure that there are no chip residues in the gas supply pipe.
- The conversion of the device from natural gas to LPG or from LPG to natural gas should be carried out by authorized service personnel.

4.8. Electrical Connections

-  Connection to the electrical network must be made by a qualified electrician in accordance with the rules and regulations.
-  Always check that the device has an effective grounding system. This requirement is only met if the device is properly connected to an effective grounding system installed in accordance with current safety standards. This basic safety measure must be checked and verified.

In case of doubt, have the electrical system checked by a qualified electrician. The manufacturer shall not be held responsible for any damage or loss of property and life caused by an ineffective grounding system or the absence of a grounding system.

- The combi boiler operates on 230 V and 50 Hz alternating current, and the maximum electricity and maximum power consumption is 82/84/117 Watts for SMF 25/30/35, respectively. The device must be protected by a 3 A fuse. Make sure that the position of the phase and neutral cables is the same as in the wiring diagram.
- Ensure that the electricity in the location where the device will be assembled is examined by a qualified electrician to ensure that it will support the maximum power shown on the device type label. In particular, make sure that the cable dimensions are suitable for the power used by the device.
- The power cord must not be replaced by the user. If the cord is damaged in any way, turn off the device and have it replaced by an authorized service.
- When replacing the power cord, use only cords with the same characteristics;

When using electrical devices, it is mandatory to observe several basic rules:

- Do not touch the device with wet or damp parts of your body or barefoot.
- Do not unplug the power cords.
- Do not expose the device to atmospheric factors (rain, sun, etc.) unless these conditions are specifically taken into account.
- Do not allow children or anyone who does not know how to use the device.

Outdoor Air Sensor, Remote Control, Room Thermostat Connections

Outdoor air sensor, remote control, and room thermostat cables should pass through the combi boiler and be connected to the terminals. These cables should pass through the PG7 connector on the bottom side of the combi boiler and be taken into the combi boiler. The position of this union is shown in Figure 18.

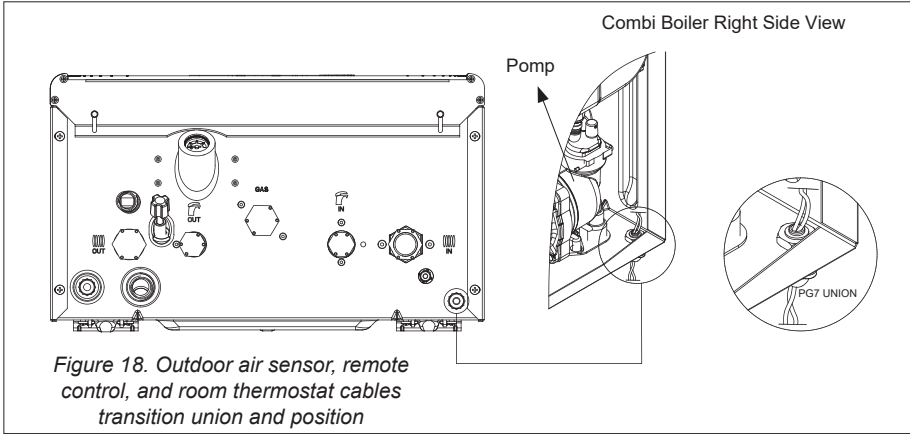

To connect the outdoor air sensor, remote control, room thermostat to the terminals, follow these steps:

- a. Turn off the power from the main switch.
- b. Remove the front cover of the combi boiler.
- c. Remove the rectangular protrusions of the plastic board from its slot in the sheet by slightly opening the plastic board support sheets to the sides.
- d. Lower the plastic board 90 degrees to the outside of the combi boiler.
- e. Remove the 4 screws in the corners and remove the back cover of the plastic board .
- f. Connect the remote control, room thermostat, and outdoor air sensor cables as shown in detail A in Figure 19.

NOTE!

The room thermostat is bridged as factory setting. If the room thermostat is not to be used, it should definitely be left bridged.

- g. When the cables are connected, insert the back cover of the plastic board, put the plastic board back to original position, and replace the front cover of the combi boiler.

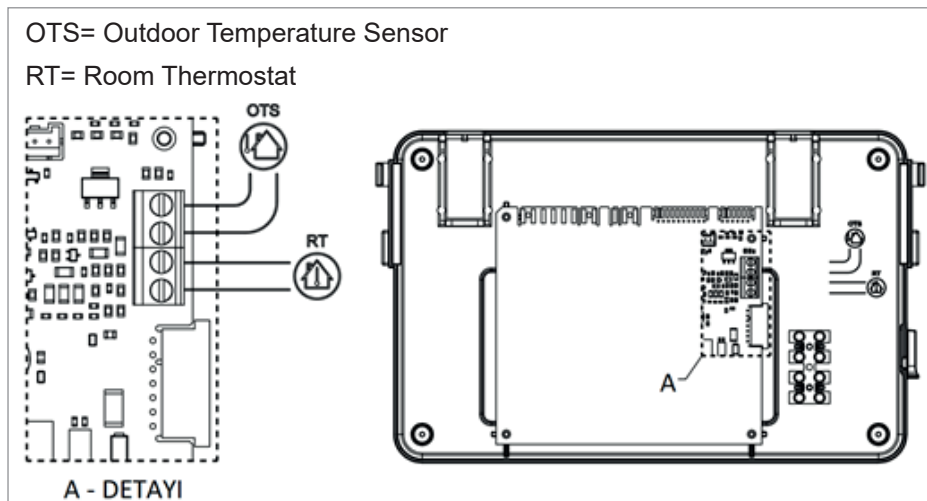

Figure 19. Interior view of the plastic board

4.9. Flue Connections

- ⚠ In order to ensure efficient and correct operation of the device, flue gas connections between the combi boiler and the flue terminal must be made using original components specially designed for condensing combi boilers.
- ⚠ Non-condensing flue gas pipes and components cannot be used to transport waste gases from condensing combi boilers.

The following recommendations should be considered in flue assembly:

In order to prevent rainwater, dust, and foreign matter from entering the horizontal fresh air suction pipes, the wall opening to the outer atmosphere should be inclined 3° outwards and downwards. The situation is different for horizontal waste gas pipes. In order to facilitate the flow of condensate water formed in the flue to the combustion cell, the waste gas pipes should be inclined 3° outwards and upwards against the risk of freezing in winter and falling on the head of people passing through the street (Figure 20). For horizontal concentric flues, the exhaust pipe facing outwards (inner pipe) should be inclined upwards and the fresh air pipe (outer pipe) should be inclined downwards. Alarko horizontal concentric flue set should be mounted parallel to the ground. When the set is assembled parallel to the ground, the exhaust pipe is automatically inclined upwards (Figure 21).

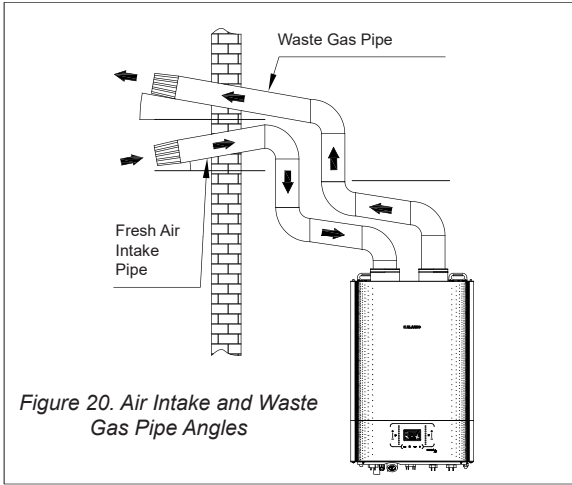

Figure 20. Air Intake and Waste Gas Pipe Angles

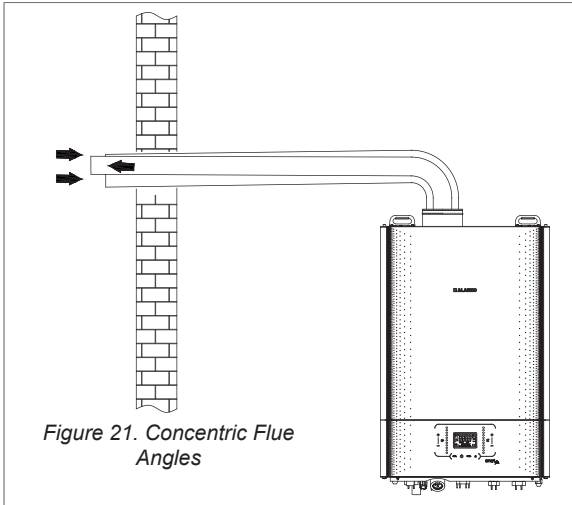

Figure 21. Concentric Flue Angles

If there is a vertical flue pipe installation, a condensate water trap is installed on the base of the flue installation and connected to the drainage system (see Figure 22).

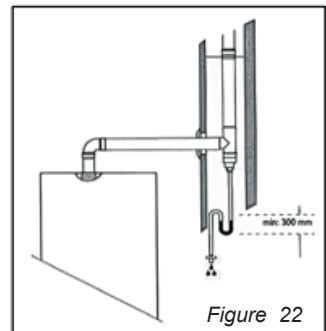
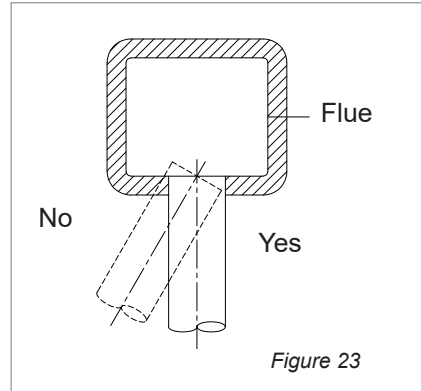

Figure 22

Flue Duct Connection

Connect the flue pipe to the flue as follows:

- Do not allow the waste gas pipe to protrude in the flue; the flue pipe should end just before it reaches the flue duct.
- The waste gas pipe must be perpendicular to the opposite wall of the flue duct (see Figure 23).



Flue Application Modes

The flue connection types are C13, C33, C33(x), C43, C43(x), C53, C53(x), C63, C63(x), C83, C83(x), C93, C93(x), B23, and B33. You can find descriptions of these types in Table 4.1 and examples of visual applications in Figure 24.

Table 4.1. Flue Types

Flue Type	Description
B23	Waste gas pipe through the flue, combustion air from the room directly through the device (open type)
B33	Waste gas pipe through the flue, combustion air from the room, horizontal concentric connection (open type)
C13(x)	Horizontal combustion air supply and discharge of waste gas from side facade or roof. The outlets have similar height and are in the same pressure zone.
C33(x)	Upright combustion air supply and waste gas disposal. The outlets have similar height and are in the same pressure zone.
C43(x)	Combustion air and waste gas are connected to the multi air waste gas system.
C53(x)	Combustion air supply consisting of separate lines and disposal of waste gas. Outlets are in different pressure zones.
C63(x)	Combustion air supply and connection design of waste gas according to non-measured devices
C83(x)	Waste gas installation with individual or multiple connections (negative pressure) and combustion air supply independent from the external environment.
C93(x)	These are the types of flues, where fresh air is sucked through a building flue shaft and waste gas is discharged from the roof. The fresh air intake pipe enters the gallery horizontally and ends by curling up with an elbow. The waste gas pipe goes from the shaft to the roof. All types can operate up to a total linear length of 50 meters including standard horizontal concentric flue length (1 meter) with 060/100 mm flue system.

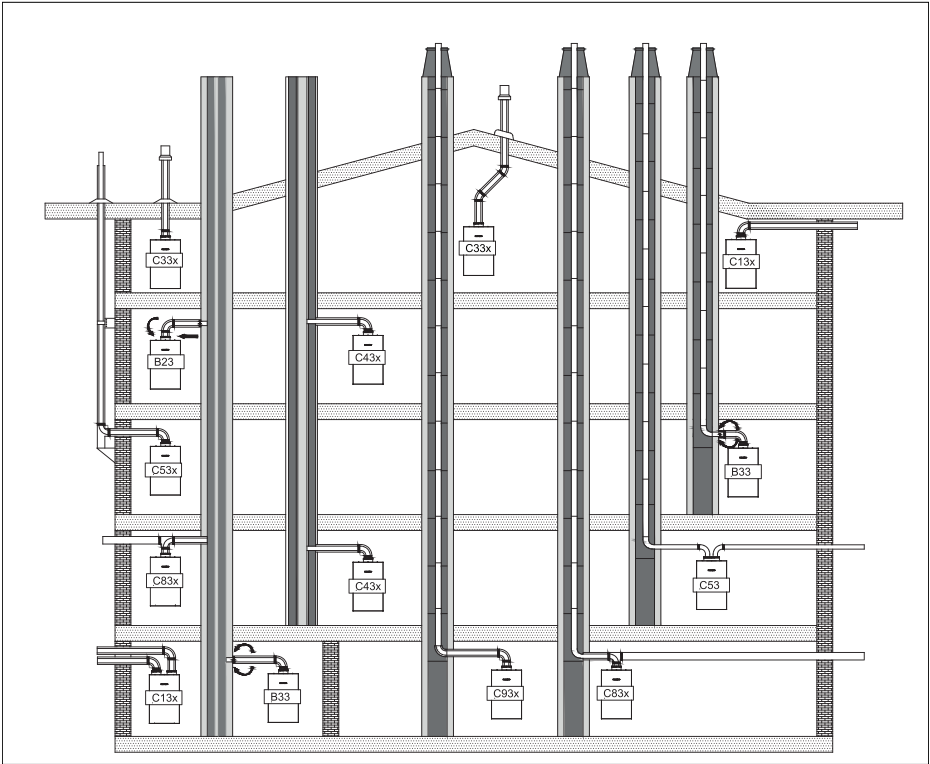

Figure 24. Flue Applications

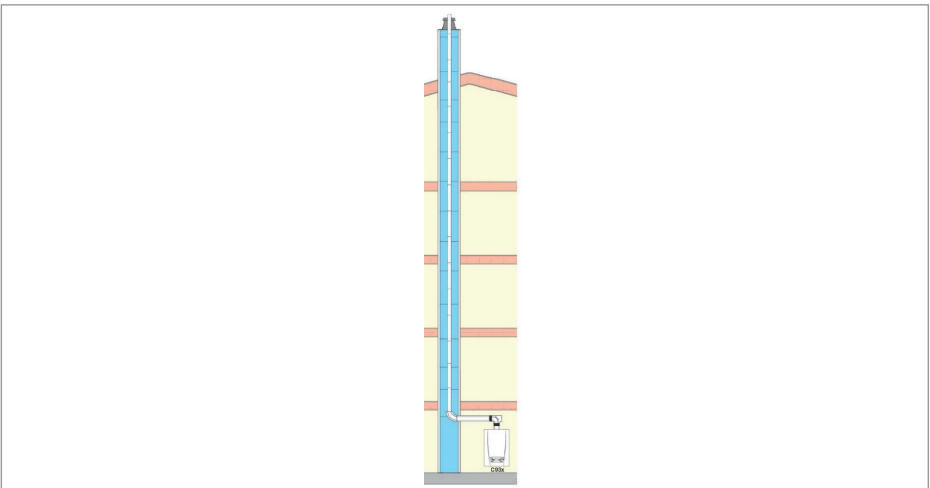

Figure 25. C93x Flue Diagram

Ø60/100 Horizontal Flue Set (SMF 25/30/35)

The horizontal concentric flue system has a 360° adjustable condensing polypropylene inner tube with a diameter of Ø60/100 mm. It discharges waste gases and draws air in from the atmosphere.

Suitable for condensing combi boilers only.

With the help of two nested pipes, it discharges waste gases and draws in fresh air. The outer Ø100 mm pipe draws in fresh air, while the Ø60 mm plastic inner pipe discharges waste gases.

The waste gas discharge pipe can be connected directly to the outside or to a suitable combined flue pipe system.

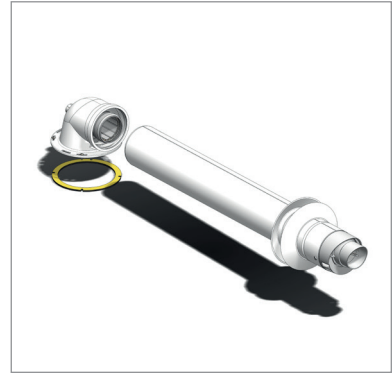

Figure 26. Ø60/100 mm
horizontal flue set

MAXIMUM FLUE LENGTH: 8 m

The maximum flue length (linear equivalent) is obtained by the sum of the length of the linear tubes and the equivalent lengths of each elbow fitted.

Linear equivalent length means the total length of the pipe, except the first elbow, from the connection of the device to the combustion chamber.

The linear equivalents of the additional elbows are as follows:

Ø 60/100 x 90° elbow = 0.8 m.

Ø 60/100 x 45° elbow = 0.5 m.

NOTE!

Use only Alarko type-approved piping systems to discharge waste gases and draw in combustion air.

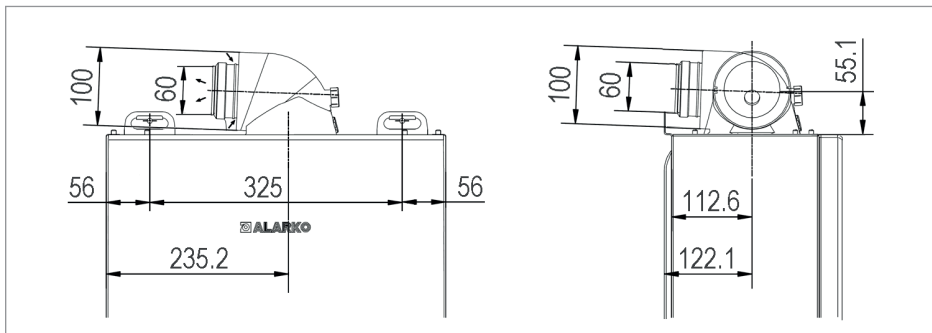

Figure 27. Ø60/100 mm horizontal flue set dimensions

Ø80+80 Twin Flue Set (SMF 25/30/35)

The horizontal split flue system consists of two polypropylene pipes with a diameter of Ø80+80 mm, adjustable 360°, suitable for condensation. While discharging waste gases from one pipe, it draws air from the atmosphere with the help of the other pipe.

Suitable for condensing combi boilers only.

With the help of two separate pipes, it discharges waste gases and draws in fresh air.

MAXIMUM FLUE LENGTH: Ø80+80: 50 m

The maximum flue length (linear equivalent) is obtained by the sum of the length of the linear tubes and the equivalent lengths of each elbow fitted.

Linear equivalent length means the total length of the pipe, except the first elbow, from the connection of the device to the combustion chamber.

The linear equivalents of the additional elbows are as follows:

Ø80 x 90° elbow = 1.5 m.

Ø80 x 45° elbow = 1.2 m.

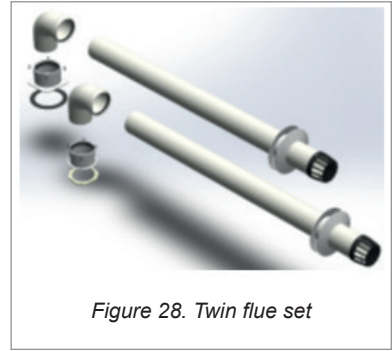

Figure 28. Twin flue set

NOTE!

Use only Alarko type-approved piping systems to discharge waste gases and draw in combustion air.

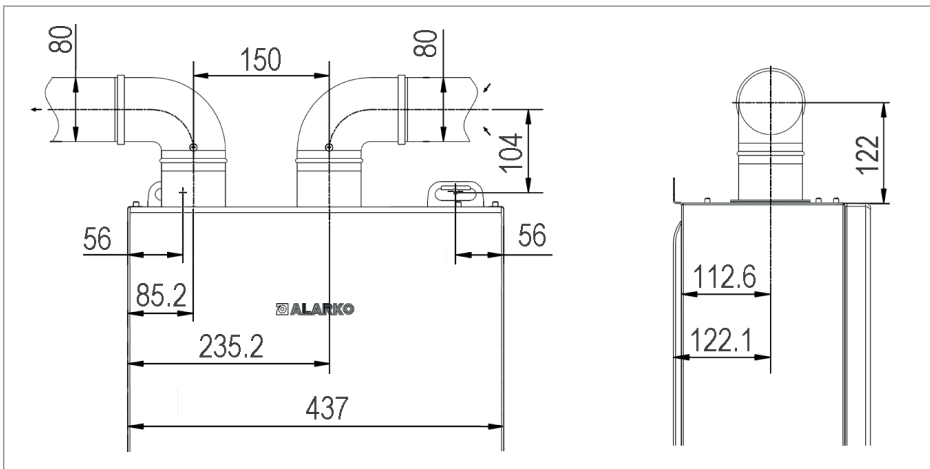

Figure 29. SMF 25/30/35 twin flue set dimensions

Ø60/100 Vertical Flue Set (SMF 25/30/35)

The vertical concentric flue system has a 360° adjustable condensing polypropylene inner tube with a diameter of Ø60/100 mm. It discharges waste gases and draws air in from the atmosphere.

Suitable for condensing combi boilers only.

With the help of two perpendicular nested pipes, it discharges the waste gases from the roof and draws in the fresh air. The outer Ø100 mm pipe draws in fresh air, while the Ø60 mm plastic inner pipe discharges waste gases.

MAXIMUM FLUE LENGTH: 8 m

The maximum flue length (linear equivalent) is obtained by the sum of the length of the linear tubes and the equivalent lengths of each elbow fitted.

Linear equivalent length means the total length of the pipe, except the first elbow, from the connection of the device to the combustion chamber.

The linear equivalents of the additional elbows are as follows:

Ø 60/100 x 90° elbow = 0.8 m.

Ø 60/100 x 45° elbow = 0.5 m.

NOTE!

Use only Alarko type-approved piping systems to discharge waste gases and draw in combustion air.

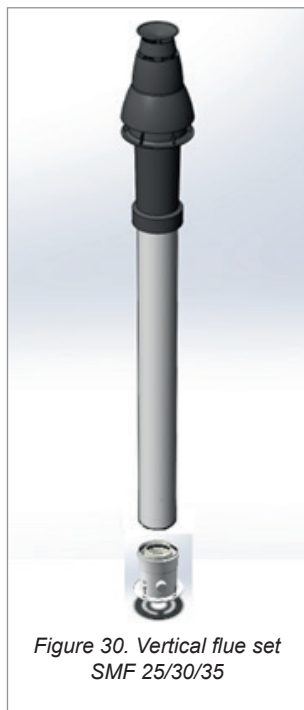

Figure 30. Vertical flue set
SMF 25/30/35

5. COMMISSIONING THE DEVICE

- ⚠ Initial commissioning will be carried out by Alarko Carrier Authorized Services free of charge. Please contact the Alarko Carrier Authorized Service in your area.
- ⚠ Initial commissioning by an unauthorized company or person voids the warranty.
- ⚠ Alarko Carrier San. ve Tic. A.Ş. shall not be responsible for the damages to device or the surrounding objects or people as a result of the initial commissioning carried out by unauthorized service or persons.

6. PERIODIC MAINTENANCE AND CLEANING

6.1. Periodic Maintenance of the Combi Boiler (Authorized Service)

Having the combi boiler serviced once a year within the warranty period and periodically before the winter season after the warranty period expires ensures your safe use, saving fuel, and prolonging the life of the device.

- ⚠ Make sure to have periodic maintenance carried out by Alarko Carrier Authorized Services.
- ⚠ Use only original spare parts to ensure the longevity and safety of the device.
- ⚠ Alarko Carrier San. ve Tic. A.Ş. shall not be responsible for the damages to device or the surrounding objects or people as a result of the maintenance carried out by unauthorized service or persons.

6.2. Maintenance Content

Maintenance includes the following items:

- Main exchanger cleaning
- Checking the burners and electrodes
- Fan motor balance control, louver cleaning
- Checking the thermostat and sensors
- Cleaning the siphon
- Checking the condensate drain
- Checking the expansion tank pressure, filling if the pressure is low
- Checking the flue sealing
- Flue gas analysis and combustion control
- Gas leakage check of gas leak detector or detergent foam and pipe and venturi lines after the gas valve

- Cleaning the strainer
- Cleaning the sludge/sediment holder
- Checking that the combi boiler is working correctly
- Filling in the authorized service certificate

6.3. Cleaning the Combi Boiler (User)

Keep the outer casing of the combi boiler clean by wiping it with a soft damp cloth. Do not use harsh, abrasive cleaning agents.

7. CONSUMER RIGHTS

1. When it is understood that the goods are defective the consumer may use one of the following options:
 - a. To withdrawal from the contract by declaring that it is ready to return the sold item,
 - b. To withhold the sold item and request a discount from the sales price at the defect rate,
 - c. To request free repair of the sold item at the seller's expense if it does not require an excessive cost,
 - ç. To request that the sold product be replaced with a non-defective one, if possible. The seller is obliged to fulfill the consumer's preferred request.
2. The right of free repair or replacement of the product with a non-defective one can also be used against the manufacturer or the importer. Seller, manufacturer, and the importer are jointly responsible for the fulfillment of these rights. The manufacturer or the importer cannot be held responsible if they prove that the defect has arisen after the product has been put on the market by them.
3. In the event that free repair or replacement of the product with a non-defective one will bring disproportionate difficulties for the seller, the consumer may use one of their rights to renege on the contract or to reduce the price at the rate of the defect. While determining the disproportion, issues like the non-defective value of the good, the importance of the fault, and whether applying for the other rights of choice would cause any problems for the consumer will be taken into account.
4. In case of choosing one of the rights of free repair or replacement of the goods with a non-defective one, it is obligatory to fulfill this request within a maximum of thirty working days, and within sixty working days for residential and holiday immovables, from the date of the request to the seller, manufacturer, or importer. However, the consumer's request for free repair regarding the goods included in the list annexed to the regulation issued pursuant to Article 58 of this Law is fulfilled within the maximum repair period

determined in the regulation. Otherwise, the consumer is free to use other rights of choice.

5. In cases where the consumer chooses the right to renege on the contract or discount at the rate of defect, the entire price paid or the amount of the discount made from the price is immediately returned to the consumer.
6. All costs incurred due to the exercise of rights of choice are borne by the party that fulfills the right chosen by the consumer. Along with one of these rights of choice, the consumer may also claim compensation in accordance with the provisions of the Turkish Code of Obligations dated 1/11/2011 and numbered 6098.

If your dispute regarding the goods/services you have purchased is related to:

- The defect in goods/services,
- The unfair terms contained in the contract you have signed with the seller/provider,
- The early payment discount to be made is wrong or not made at all in case you make an early payment for the goods/services you purchased in installments,
- The failure to deliver the goods/services you purchased with a campaign (prepaid) on time and properly,
- The failure to deliver the goods/services you have received through the distance contract (internet, TV, etc.) on time and the failure to return the price despite you exercising your right of reneging, you will need to apply to the Consumer Arbitration Committee or the Consumer Court located within the Provincial Directorate of Commerce and District Governorship where you reside or where you purchase the goods/services, taking into account the disputed amount, in order to resolve your dispute. If there is no Consumer Court in your location, you can apply to the Civil Courts of First Instance in the capacity of Consumer Court.

If your dispute is related to:

- The failure to deliver a warranty certificate, Turkish introduction and user manual with the goods you have purchased,
- The failure to give you the contract, which is required in the Law to be arranged in writing and a copy to be given to you, you can apply to the Provincial Directorate of Commerce located in the Governorship of the province you reside in order to carry out the necessary administrative procedures.

8. INFORMATION RELATED TO EFFICIENT USE IN TERMS OF ENERGY CONSUMPTION

ENERGY-SAVING RECOMMENDATIONS

- To obtain high efficiency from your condensing device, set the heating water to 50°C or lower.
- Do not set the domestic water temperature to 40°C and above. Thus, you will also avoid the risk of scalding.
- Close the heating radiator valves of the ventilated environment during ventilation.
- The use of a thermostatic valve and a room thermostat is very important for comfortable heating. If they are not present, provide a thermostatic valve for the room thermostat and/or heating radiators that are compatible with your device.

Sudden and complete closing or opening of the thermostatic valve causes undesirable temperature fluctuations. Therefore, open and close the thermostatic valves in small steps.

If there is a program time in the room thermostat, take into account the hours and holidays when you will not be at home when making the adjustment.

- Be careful not to cover the top and front of the heating radiators with objects such as curtains, furniture, etc.
- A room temperature of 20°C is sufficient for the winter months. Further heating will increase energy consumption.
- Have your device serviced by an authorized service at least once a year for efficient operation and possible troubleshooting.

ALARKO



ALARKO CARRIER
SANAYİ VE TİCARET A.Ş.

İSTANBUL : GOSB - Gebze Org. San. Bölgesi, Ş. Bilgisu Cad. 41480 Gebze-KOCAELİ
Tel: (0262) 648 60 00 - Fax: (0262) 648 60 08
ANKARA : Sedat Simavi Sok. No: 48, 06550 Çankaya - ANKARA
Tel: (0312) 409 52 00 - Fax: (0312) 440 79 30
İZMİR : Şehit Fethibey Cad. No:55, Kat:13, 35210 Pasaport - İZMİR
Tel: (0232) 483 25 60 - Fax: (0232) 441 55 13
ADANA : Ziyapaşa Bulvarı Çelik Ap. No : 25/5-6, 01130 ADANA
Tel: (0322) 457 62 23 - Fax: (0322) 453 05 84
ANTALYA : Mehmetçik Mahallesi Aspendos Bulvarı No: 79/5 - ANTALYA
Tel: (0242) 322 00 29 - Fax: (0242) 322 87 66
MDH : 444 0 128

web: www.alarko-carrier.com.tr
e-posta: info@alarko-carrier.com.tr