

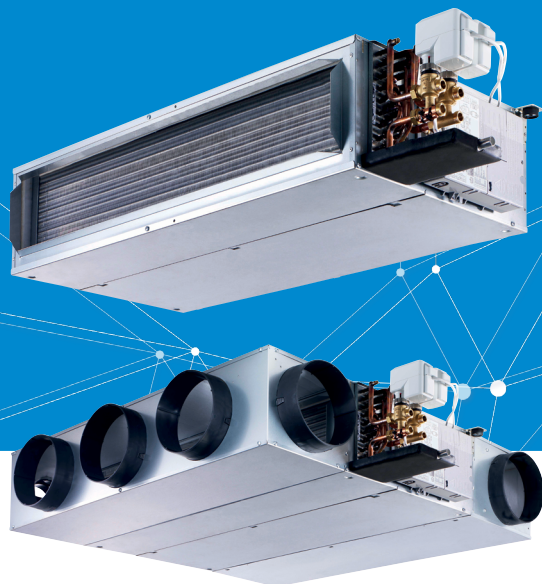

PRODUCT SELECTION DATA

DUCTABLE FAN COIL UNIT



- Ductable unit for suspended ceiling
- Extremely quiet operation
- Low Energy Consumption
- Flexibility for simplified installation
- Improved comfort
- Indoor air quality

42NL & 42NH



The Carrier 42NH and 42NL are available in different sizes with 2-pipe, 2-pipe plus electric heater or 4-pipe coils, with an air flow range from 100 to 2300 m³/h, a total cooling capacity range from 0.6 kW to 12 kW and a nominal heating capacity range from 0.8 kW to 17 kW.



CARRIER participates in the ECP programme for FC/FCP
Check ongoing validity of certificate:
www.eurovent-certification.com

1 - FUNCTIONS AND CONFIGURATIONS

- Compact and modular ducted unit, designed for any false ceiling installation.
- Reliable and economical for tertiary building as hotel guest rooms, offices or light commercial applications.
- Low height of 235 mm (sizes 2/3/4/5) and 285 mm (sizes 6/7)
- Compatible with the Carrier diffuser ranges.
- Extremely low sound levels for ducted applications.
- Five- to Six- speed fan AC motors offers a wide choice of medium speeds.
- Available with Low Energy Consumption variable-speed EC motor.
- High-pressure centrifugal fan for 42NH Range
- G3 filter as standard.
- Safe factory installed electric heater with multiple capacity stages choices.
- Low water pressure drop with factory installed valves.
- Factory installed options (valves and controllers) for fast and easy installation in false ceilings.

1.1 - Modularity

Thanks to its two versions, the range is suitable for all applications.

The 42NL version is optimised for soffit installations while the 42NH is optimised for air return and supply ducted installations.

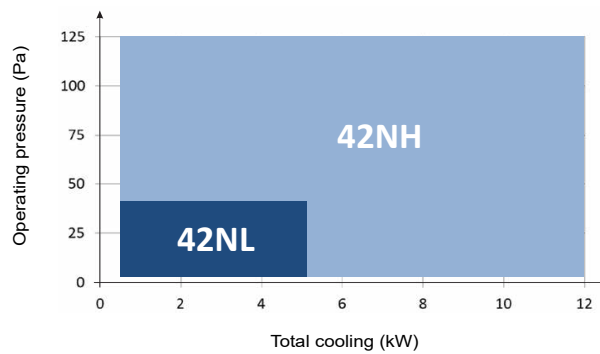

1.2 - Configuration and flexibility

Each of the 42NL and 42NH sizes can be equipped:

- With non-ducted return and/or direct supply;
- With a rectangular flange on the return and/or supply (ideal for connecting the fan coil unit to the air duct);
- With return and/or plenums including a large number of spigots with diameters of 160, 200 or 250 mm depending on the unit size.

The image below shows all available plenum configurations on the 42NL or 42NH (e.g. size 3) with a spigot diameter of 200 mm.

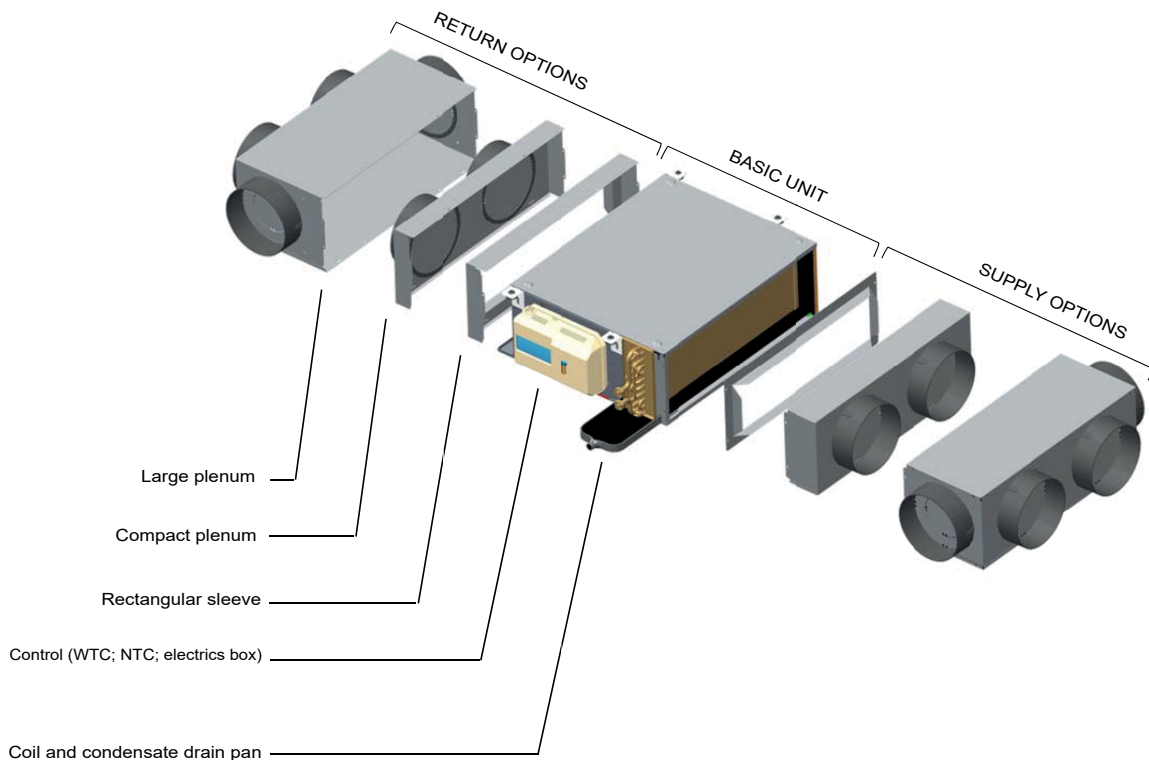

1 - FUNCTIONS AND CONFIGURATIONS

1.3 - Standard spigot configuration

Large and small plenums are available for all sizes as per the drawings below:

(*) = Minimum number of spigots required to ensure sufficient available static pressure and fan reliability

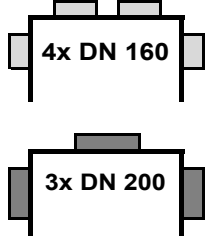
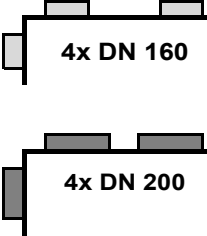
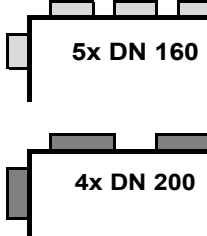
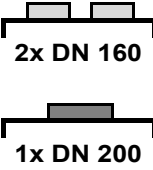
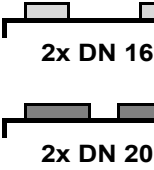
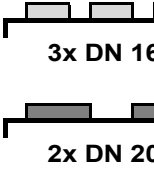
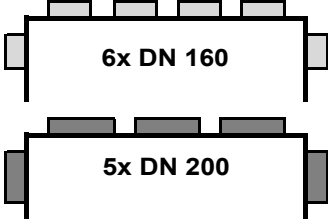
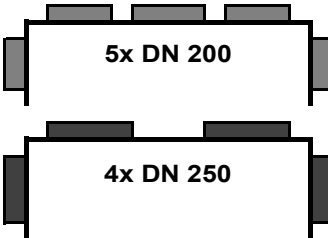
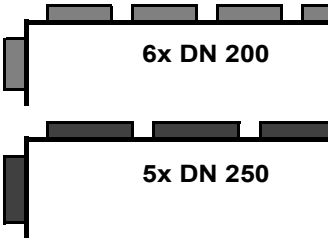
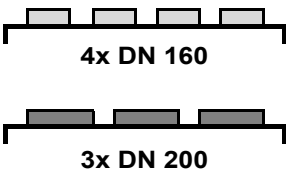
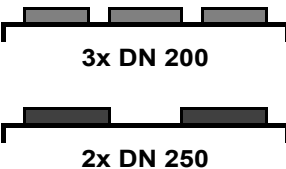
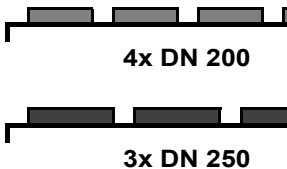
	42NH & 42NL Size 2xx	42NH & 42NL Size 3xx	42NH & 42NL Size 4xx
LARGE RETURN OR SUPPLY			
COMPACT RETURN OR SUPPLY			
LIMITS (*)	MIN. NO. OF SPIGOTS = 1x160 or 1x200 (2x160 and 1x200 for 42NH279)	MIN. NO. OF SPIGOTS = 2x160 or 1x200 (2x160 and 2x200 for 42NL range)	MIN. NO. OF SPIGOTS = 3x160 or 2x200
	42NH & 42NL Size 5xx	42NH Size 6xx	42NH Size 7xx
LARGE RETURN OR SUPPLY			
COMPACT RETURN OR SUPPLY			
LIMITS (*)	MIN. NO. OF SPIGOTS = 3x160 or 2x200 (4x160 and 3x200 for 42NL range)	MIN. NO. OF SPIGOTS = 3x200 or 2x250	MIN. NO. OF SPIGOTS = 4x200 or 3x250

NOTE:

- Electrical heater are not available for 42NL Units when plenum are selected (due to minimum airflow requirement).
- Non-standard configurations not listed above can be provided upon special request. Contact your local Carrier representative.

1 - FUNCTIONS AND CONFIGURATIONS

Standard configuration with return and supply rectangular sleeves:

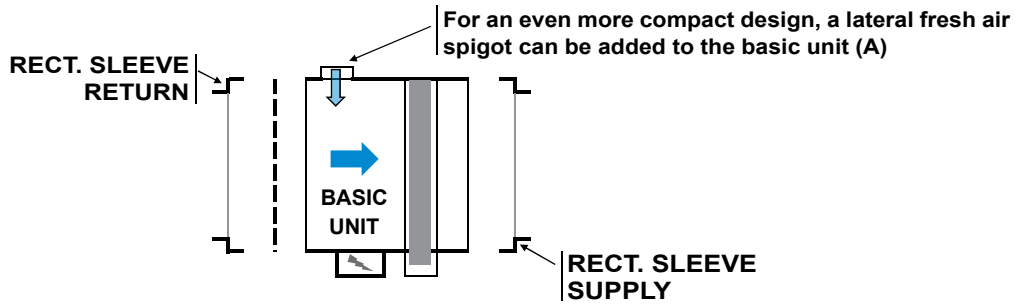

Standard configuration with spigots without fresh air:

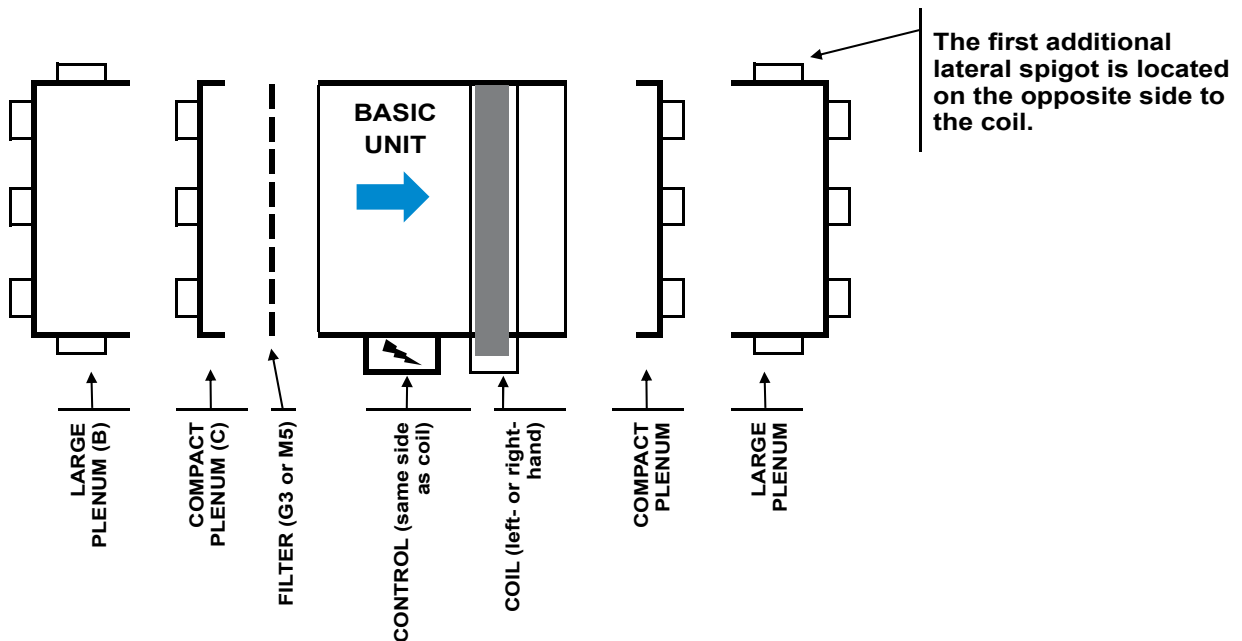

Standard configuration with fresh air return possibilities:

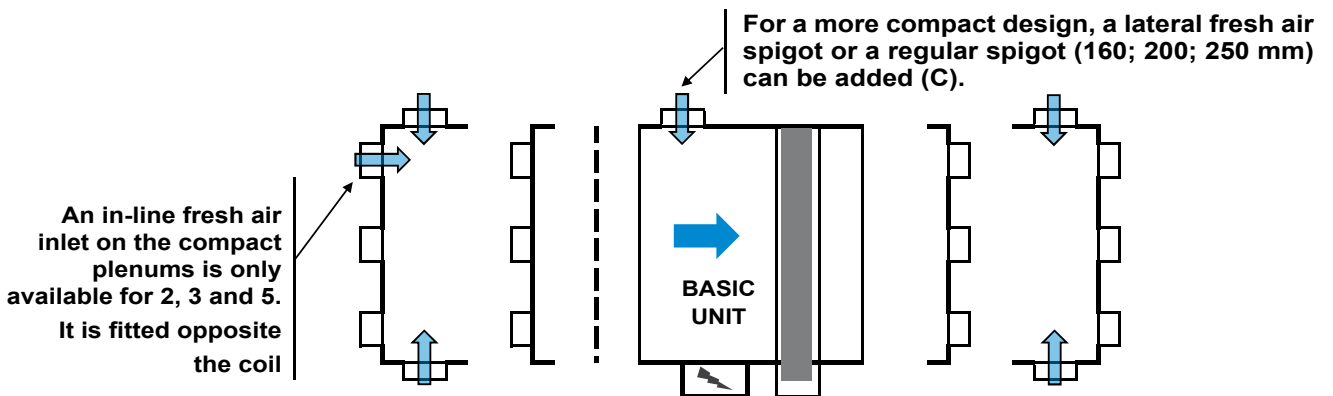

- Air flow direction
- Fresh air inlet

- (A) In this case, the air must be filtered beforehand to prevent any damage to the fan and the soiling of the coil.
- (B) Large plenum is required to fit the M5 filter
- (C) Without any filter the small inlet plenum is flat for improved compacity.

1 - FUNCTIONS AND CONFIGURATIONS

Additional configurations are displayed below:

U-shaped

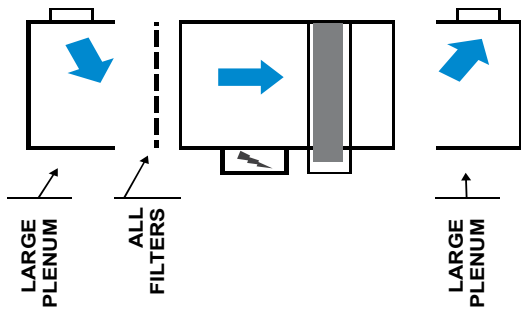

L-shaped

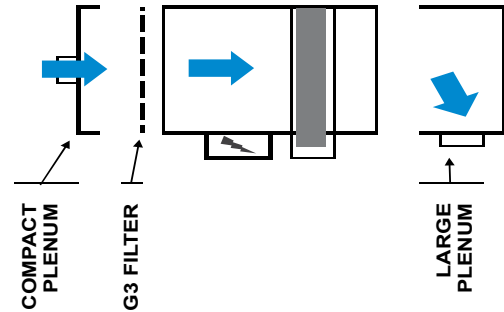

T-shaped

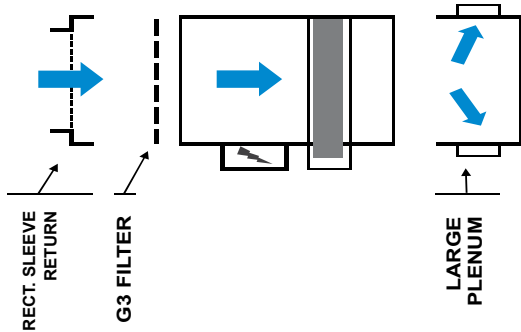

H-shaped or I-shaped

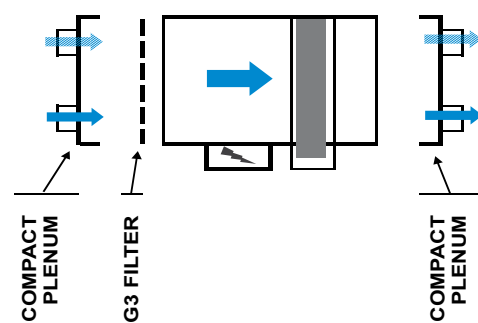

Configurations without filter (ultra-compact design)

U-shaped

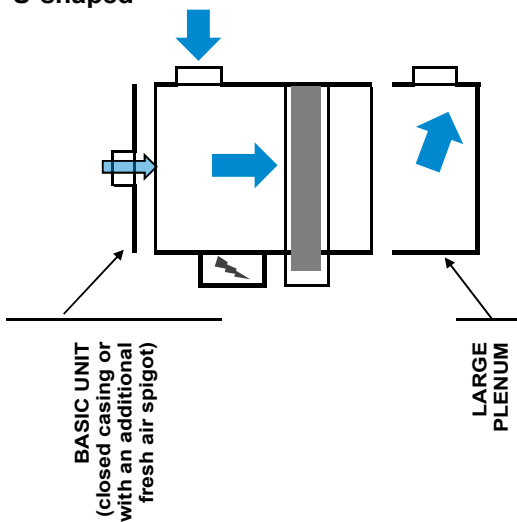

H-shaped or I-shaped

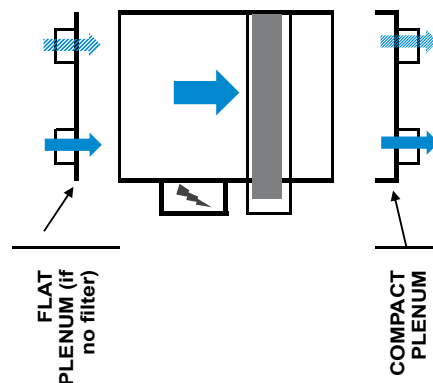

Compatibility Reminder	Size 2		Size 3	Sizes 4 to 7
	22x / 23x	279		
1x160	NH/NL	n.a.	n.a.	n.a.
1x200	NH/NL	NH	NH	n.a.
1x250	n.a.	n.a.	n.a.	n.a.

Compatibility Reminder	Size 2 to 3	Size 4	Size 5	Size 6	Size 7
2x160	NH/NL	n.a.	n.a.	n.a.	n.a.
2x200	NH/NL	NH/NL	NH	n.a.	n.a.
2x250	n.a.	n.a.	n.a.	NH	n.a.

NA: Not Available

1 - FUNCTIONS AND CONFIGURATIONS

M5 filter configurations

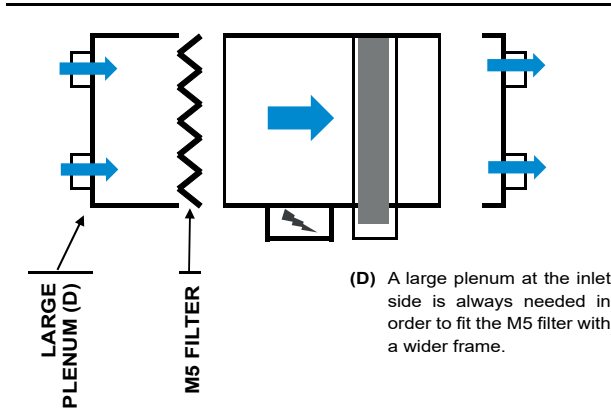

Lateral fresh air configuration at the supply side

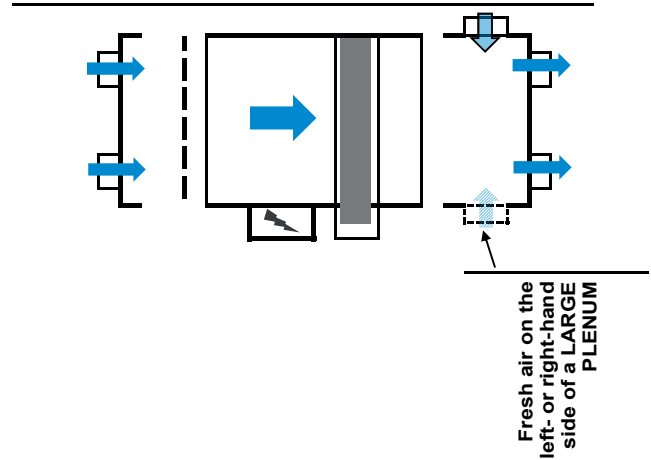

Fresh air configurations at the return side

Lateral fresh air (opposite side to coil) Option 1 "Optimised"

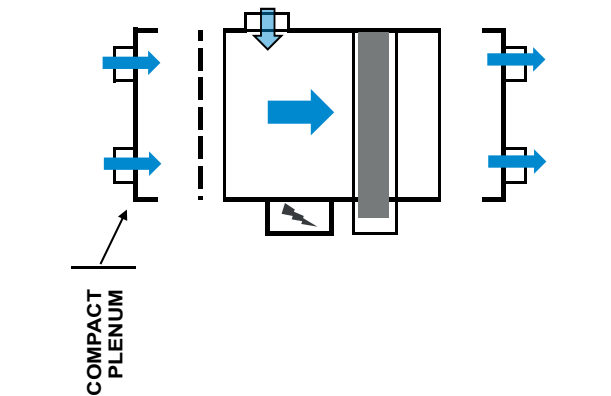

Inlet optimised: for a compact design, the fresh air is fitted on the basic unit (on the opposite side to the coil).

Option 2 "In_opp"

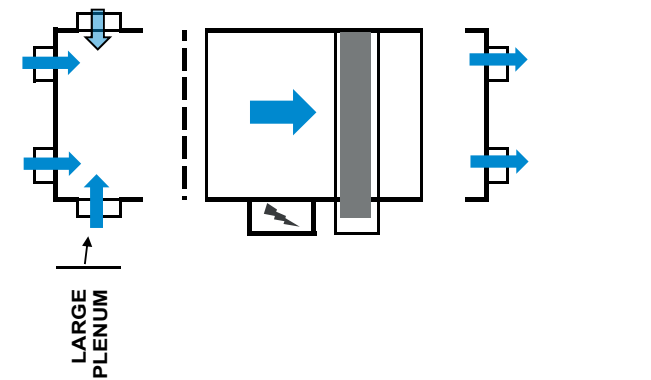

With this option, the fresh air is located opposite the coil and is always installed in a large plenum.

Lateral fresh Air "In_coil"

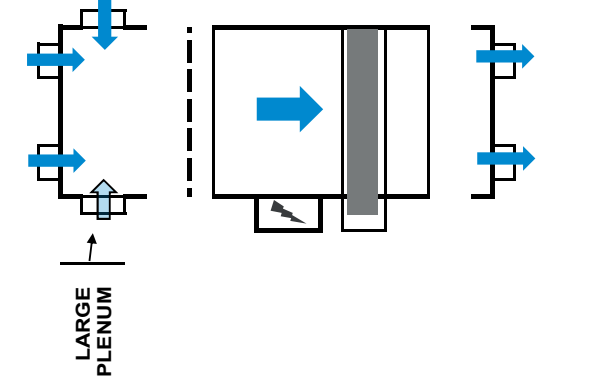

"In_line" fresh air (for sizes 2, 3 and 5)

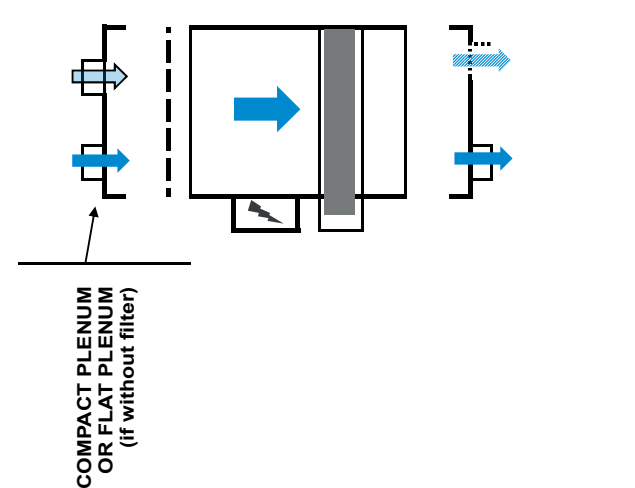

2 - DIMENSIONAL DRAWINGS

NOTE: All the drawings show the coil connection on the right-hand side. Coils with left-hand connections are strictly symmetrical,

Standard unit without rectangular return and supply flanges

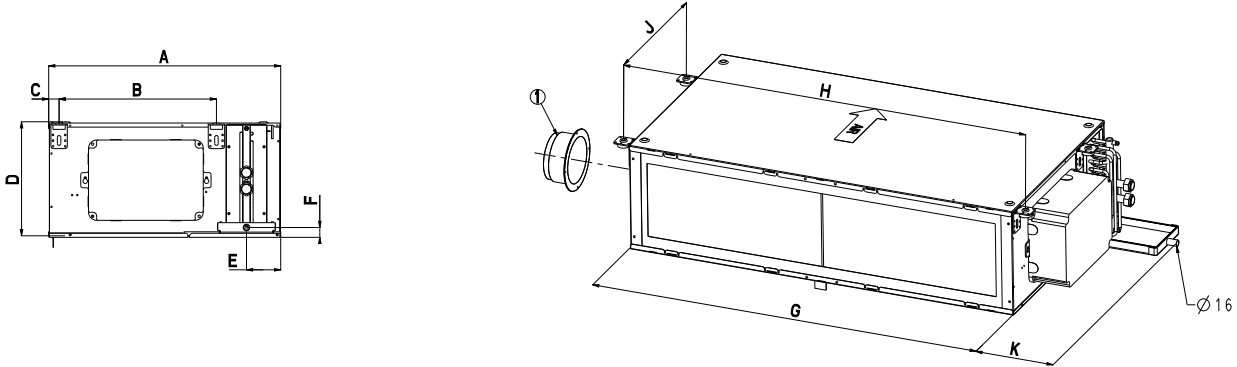

Dimensions in mm						
Size	2xx	3xx	4xx	5xx	6xx	7xx
A	520	520	520	520	575	575
B	330	330	330	330	385	385
C	25	25	25	25	25	25
D	235	235	235	235	285	285
E	85	85	85	85	85	85
F	17	17	17	17	25	25

Dimensions in mm						
Size	2xx	3xx	4xx	5xx	6xx	7xx
G	450	620	820	1020	1020	1320
H	500	670	870	1070	1070	1370
J	330	330	330	330	385	385
K	230	230	230	230	230	230
G + K	680	850	1050	1250	1250	1550
Weight* [kg]	15	18	23	27	30	36

Standard unit with rectangular sleeves on the return and supply

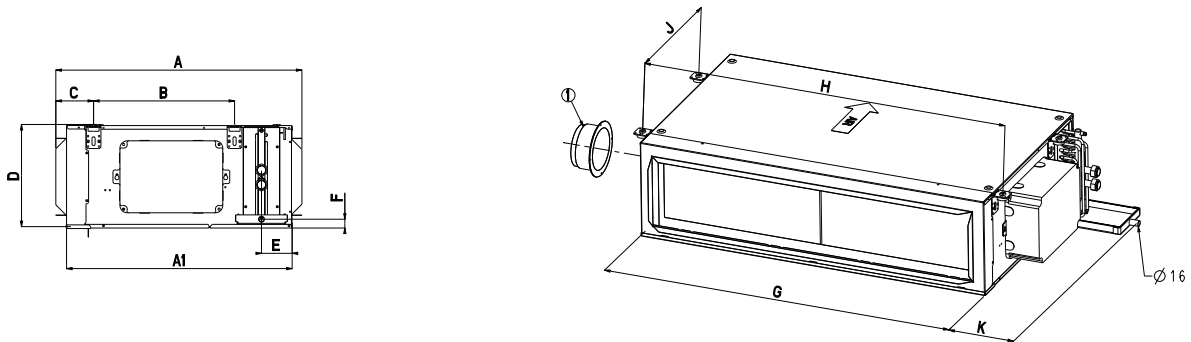

Dimensions in mm						
Size	2xx	3xx	4xx	5xx	6xx	7xx
A	615	615	615	615	670	670
B	330	330	330	330	385	385
C	103	103	103	103	103	103
D	235	235	235	235	285	285
E	85	85	85	85	85	85
Rectangular Flanges	380 x 160	550 x 160	750 x 160	950 x 160	950 x 210	1250 x 210

Dimensions in mm						
Size	2xx	3xx	4xx	5xx	6xx	7xx
F	17	17	17	17	25	25
A1	561	561	561	561	615	615
G	450	620	820	1020	1020	1320
H	500	670	870	1070	1070	1370
J	330	330	330	330	385	385
K	230	230	230	230	230	230
G + K	680	850	1050	1250	1250	1550
Weight* [kg]	15	18	23	27	30	36

KEY

- 1 Lateral optimized fresh air position in base unit (opposite to coil hand at inlet)
 - * Maximum weight 42NL/NH (AC or EC motor version) - without valve option - without water
 - Air flow direction
- All dimensions are in mm.

2 - DIMENSIONAL DRAWINGS

Unit without filter with compact plenum at return and supply (optimised length)

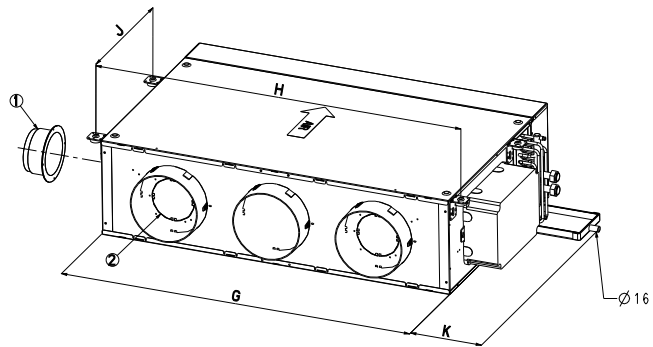
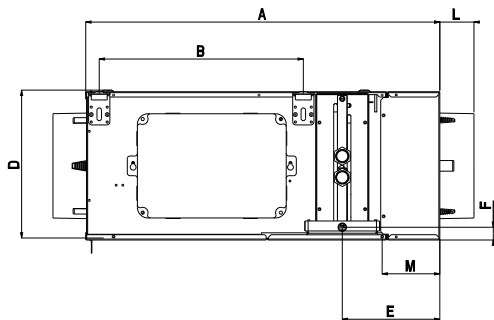

Dimensions in mm						
Size	2xx	3xx	4xx	5xx	6xx	7xx
A	611	611	611	611	666	666
B	330	330	330	330	385	385
C	25	25	25	25	25	25
D	235	235	235	235	285	285
E	185	185	185	185	185	185
F	17	17	17	17	25	25
G	450	620	820	1020	1020	1320

Dimensions in mm						
Size	2xx	3xx	4xx	5xx	6xx	7xx
H	500	670	870	1070	1070	1370
J	330	330	330	330	385	385
K	230	230	230	230	230	230
L	63	63	63	63	76	76
M	100	100	100	100	100	100
G + K	680	850	1050	1250	1250	1550
Weight* [kg]	19	23	29	33	37	44

Unit with G3 filter and compact plenum at the return and supply

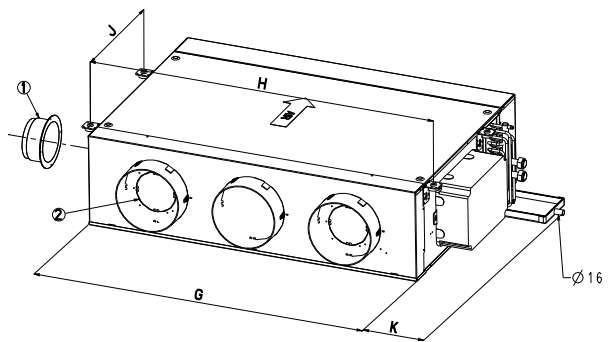
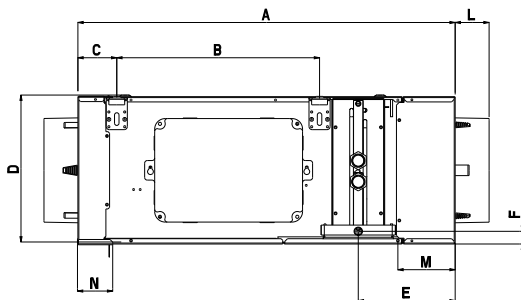

Dimensions in mm						
Size	2xx	3xx	4xx	5xx	6xx	7xx
A	660	660	660	660	715	715
B	330	330	330	330	385	385
C	75	75	75	75	75	75
D	235	235	235	235	285	285
E	185	185	185	185	185	185
F	17	17	17	17	25	25
G	450	620	820	1020	1020	1320

Dimensions in mm						
Size	2xx	3xx	4xx	5xx	6xx	7xx
H	500	670	870	1070	1070	1370
J	330	330	330	330	385	385
K	230	230	230	230	230	230
L	63	63	63	63	76	76
M	100	100	100	100	100	100
N	50	50	50	50	50	50
G + K	680	850	1050	1250	1250	1550
Weight* [kg]	19	23	29	33	37	44
G + K	680	850	1050	1250	1250	1550
Weight* [kg]	19	23	29	33	37	44

KEY

- 1 Lateral optimized fresh air position in base unit (opposite to coil hand at inlet)
 - 2 In line fresh air position for compact plenum (with or without filter)
 - * Maximum weight 42NL/NH (AC or EC motor version) - without valve option - without water
- Air flow direction
 All dimensions are in mm.

2 - DIMENSIONAL DRAWINGS

Unit with G3 or M5 filter and large plenum at the return and supply

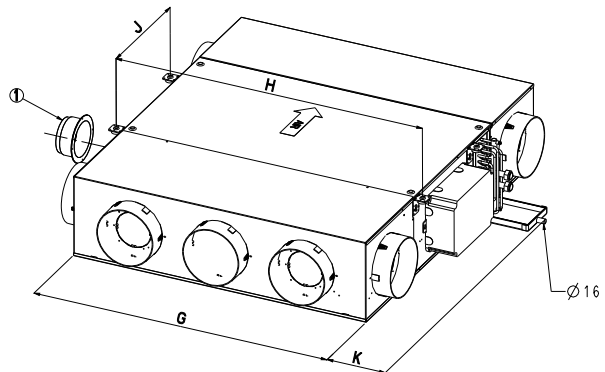
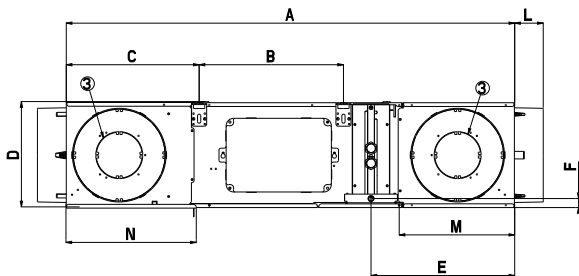

Dimensions in mm						
Size	2xx	3xx	4xx	5xx	6xx	7xx
A	1040	1040	1040	1040	1195	1195
B	330	330	330	330	385	385
C	305	305	305	305	355	355
D	235	235	235	235	285	285
E	333	333	333	333	382	382
F	17	17	17	17	25	25
G	450	620	820	1020	1020	1320

Dimensions in mm						
Size	2xx	3xx	4xx	5xx	6xx	7xx
H	500	670	870	1070	1070	1370
J	330	330	330	330	385	385
K	230	230	230	230	230	230
L	63	63	63	63	76	76
M	250	250	250	250	297	297
N	280	280	280	280	330	330
G + K	680	850	1050	1250	1250	1550
Weight* [kg]	22	27	34	40	45	53

KEY

- 1 Lateral optimized fresh air position in base unit (opposite to coil hand at inlet)
 - 3 Lateral fresh air position in large plenum (at inlet or outlet side)
 - * Maximum weight 42NL/NH (AC or EC motor version) - without valve option - without water
- Air flow direction
 All dimensions are in mm.

Water coil

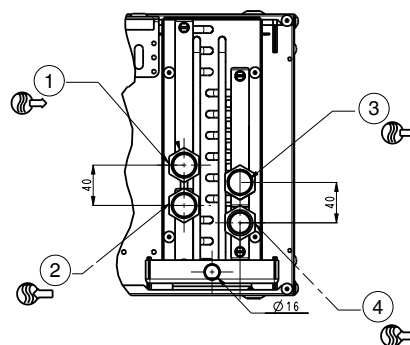
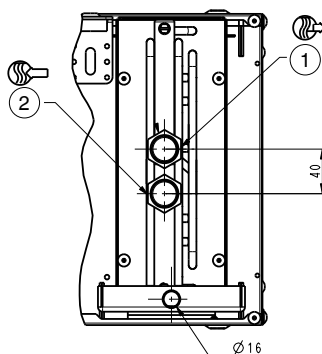

DN:
 1/2" 42NH/NL 2xx, 3xx, 4xx, 5xx
 3/4" 42NH 6xx, 7xx

- 1 Cooling water outlet for 4-pipe coil and heating/cooling for 2-pipe coil
- 2 Cooling water inlet for 4-pipe coil and heating/cooling for 2-pipe coil
- 3 Heating water outlet (4-pipe coil)
- 4 Heating water inlet (4-pipe coil)

3 - MAIN MODULES AND COMPONENTS

3.1 - Casing

In order to further enhance occupant comfort, this product range offers especially low noise levels. The casing is made of galvanised sheet steel with full high-efficiency internal lining for optimised thermal and sound insulation of the unit.

In order to comply with the various local regulations (fire class) the fan-coil unit is available with both class M1 type insulation (according to NF P 92-507) and Euroclass level B-s3-d0 (according to EN 13501). It is also equipped with anti-vibration mounts as standard.

In order to reduce the dimensions to the minimum, the units are equipped with high-efficiency heat exchangers with very high cooling capacity/treated air flow ratios. The condensate drain pan height is optimised.

3.2 - Fan motor assemblies

3.2.1 - Multi-speed fan motor assembly compliant with ErP 2015 regulations

Motor description

- Asynchronous motors, 4 poles with internal overload protection
- Permanent capacitor
- Class B winding insulation, varnish class F
- See operating limits in chapter 8.

The 42NH and 42NL have a multi-speed fan motor assembly with forward curved, double inlet, single, double or triple wheel fans depending on the unit size.

Five speeds are available as standard for 42NH (Six speeds for 42NL). Three speeds must be selected to allow connection of the fan motor in accordance with applicable electromechanical or electronic control.

- Minimum speed: R5 for 42NH; R6 for 42NL
- Maximum speed: R1
- Units can be supplied with Carrier electronic controls and prewired to a selection of three speeds.
- For other fan motor Speed wiring combinations refer to the unit options list (chapter 6).

3.2.2 - Low-consumption fan motor assembly (variable-speed LEC)

Motor description

- Permanent magnet brushless motor
- Electronically commutated
- Class B winding insulation, varnish class F
- See operating limits in chapter 8.

The 42NH and 42NL units are equipped with the LEC fan motor, which is controlled by a 0 to 10 V signal, available with the Carrier NTC or WTC type electronic control.

NOTE: In this case the minimum control signal that allows the motor to start is 2 V for two- and four-pipe versions and 3 V for versions equipped with electric heaters.

If the product is supplied without a Carrier control device, verification of EMC conformity is the responsibility of the installer.

3.3 - Fan wiring solutions

3.3.1 - Multi-speed unit with bare wires (standard)

As standard, all speeds of the multi-speed fan are available with bare wires (six speeds for the 42NL and five speeds for the 42NH), offering greater flexibility.

Minimum speed = R6 or R5, maximum speed = R1.

3.3.2 - Multi-speed unit with optional controller or electrics box

When ordering, three of the five speeds must be selected to enable the motor connection to comply with the applicable controller (NTC, WTC or electrics box for Carrier thermostats).

With the electrical box, the installer can connect the unit to a terminal board. The electrical box can be opened with a screw driver.

The electrical box permits changing the speed wiring without access to the motor. All available speeds are connected.



Wiring example: By default, R5 R3 R1 are connected on the terminal board.
The other 2 or 3 speeds are available and easy to access

NOTE: The standard wiring for all unit ranges is always R5 R3 R1.

3.3.3 - Variable-speed low energy consumption (LEC) fan motor with bare wires (standard)

The variable-speed low energy consumption (LEC) motor must be controlled by a 0-10 VDC signal.

3.3.4 - Variable-speed low energy consumption (LEC) fan motor with electrics box

This option allows the installer to connect the unit to a terminal board inside an electrical box. The electrical box can be opened with a screw driver.

The 0-10 VDC signal that controls the variable-speed fan is directly accessible at the terminal strip.

3.3.5 - Cover only option

A plastic cover accessory can be added to house a controller supplied by the customer (max. dimensions L = 200 mm x D = 100 mm x H = 95 mm). It is installed on site or in the factory on a multi-speed unit or on a variable speed fan motor with low energy consumption (LEC).

NOTE: This option is not compatible with the electrics box option.

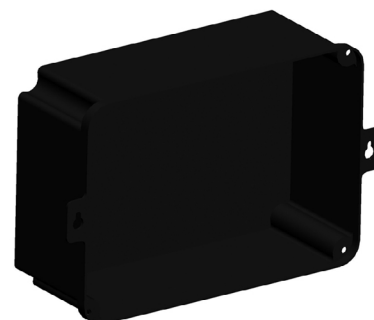

3 - MAIN MODULES AND COMPONENTS

3.3.6 - Fuse holder option

A fuse holder can be provided as an option for all controllers or with the electrics box.

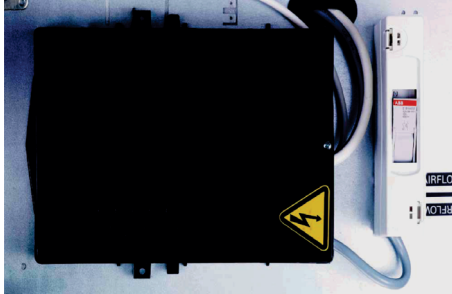

3.4 - Hydraulic coil

- Aluminium fins mechanically bonded by expansion onto copper tubes
- 1/2-inch threaded female water inlet and outlet connections for sizes 2 to 5
- 3/4-inch threaded female water inlet and outlet connections for sizes 6 and 7
- Air bleed valves and drain as standard.
- Operating pressure 1550 kPa.

The coil, condensate drain pan and coil access door are in the form of an easily removable drawer.

3.5 - Single unit condensate drain pan

Single unit condensate drain pan made from polypropylene and insulated with 5 mm of foam.

Drain connection diameter: Ø 16 mm external
HB fire rating (in compliance with UL94).

3.6 - Filter

3.6.1 - Specifications

The 42NH and 42NL include as standard a G3 filter in compliance with EN 779.

A pleated M5 filter (for range 42NH only) according to EN 779 are also available. G3 and M5 filters have medium fire rating M1 (according to NFP 92-507) and a metal frame.

The "without filter" option is only available for units with a rectangular sleeve on the return side to ensure that a duct can be connected when the unit operates.

To prevent coil fouling, Carrier recommends the use of a filter installed in either the fan coil unit or in the return air grille.

The 42NH offers four filter configurations:

- Without filter: only available for units with an inlet plenum with spigots or with a rectangular flange inlet
- G3 filter: metal wire frame, medium efficiency supplied as standard
- M5 filter (only for 42NH): metal wire frame, high efficiency, thickness = 55 mm.

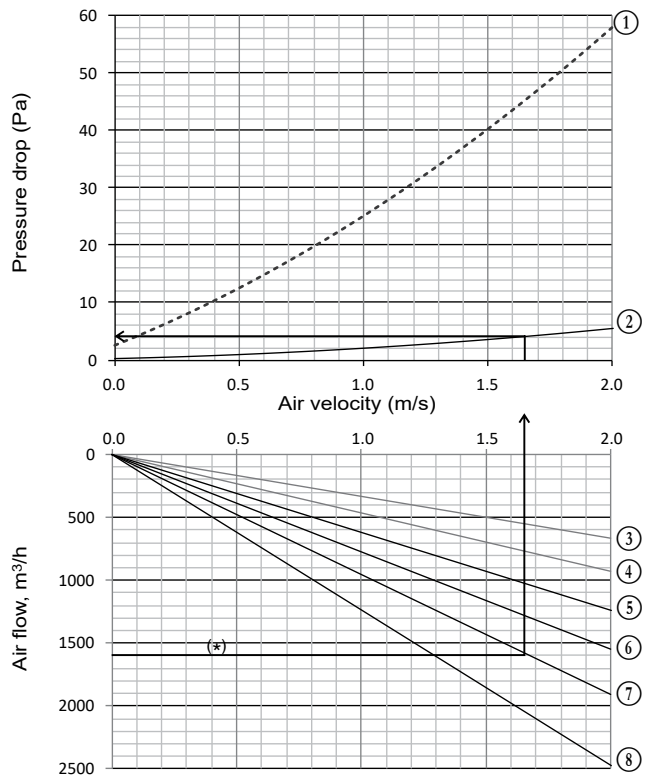

Key

- 1 M5 filter
 - 2 G3 filter
 - 3 Airflow for 42NH/NL Size 2
 - 4 Airflow for 42NH/NL Size 3
 - 5 Airflow for 42NH/NL Size 4
 - 6 Airflow for 42NH/NL Size 5
 - 7 Airflow for 42NH Size 6
 - 8 Airflow for 42NH Size 7
- (*) Example: The pressure drop of a G3 filter used in a 42NH645 is 5 Pa for a 1600 m³/h air flow.

3 - MAIN MODULES AND COMPONENTS

3.6.2 - Filter access

Without a rectangular return sleeve, the filter is removed from the rear.

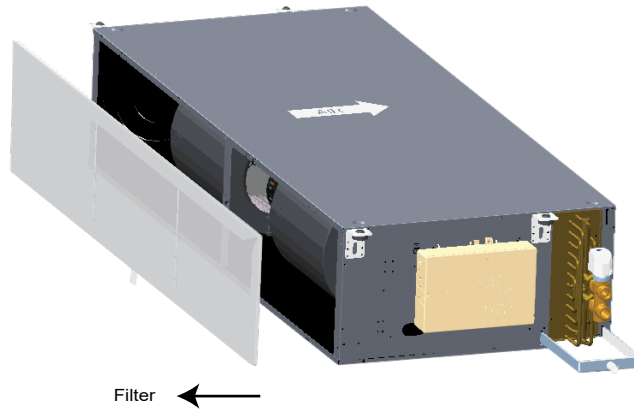

With a rectangular sleeve or return plenum, the filter is removed from below (hatch).

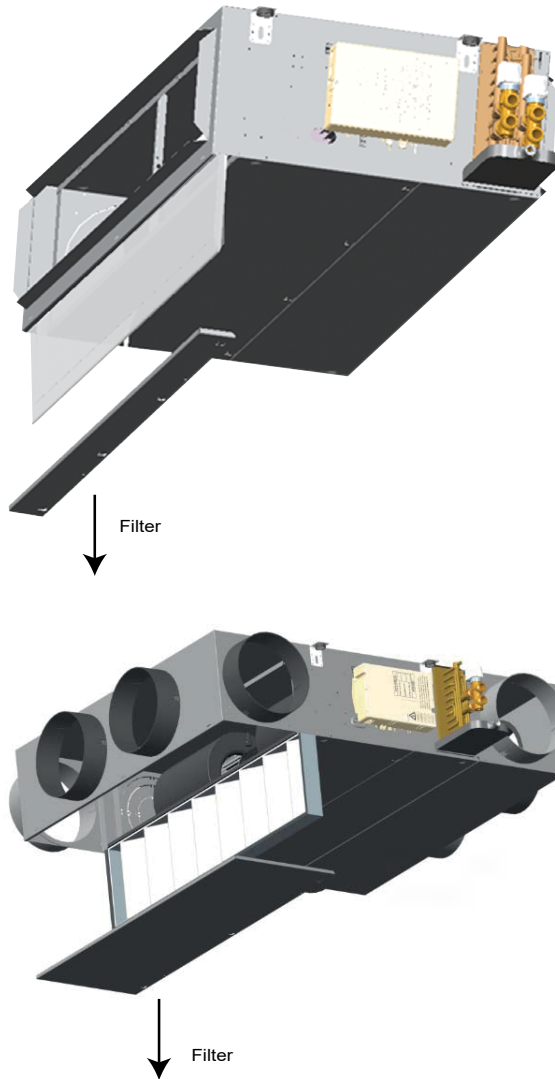

4 - OPTIONS SPECIFICATIONS

4.1 - Electric heater (option for 2-pipe coil)

Resistive wire type heater

- Supply voltage: 230 V - 1 ph - 50 Hz
- Heater size and capacity per unit (+5% ; -10%):

Electrical Heater Capacity	Low	Medium	High	Very High
42NH/NL 2-5	1 x 500 W	1 x 800 W	1 x 1000 W	NA
42NH/NL 2-9	1 x 500 W	1 x 800 W	1 x 1000 W	NA
42NH/NL 3-5	1 x 500 W	1 x 800 W	1 x 1000 W	1 x 1600 W
42NH/NL 3-9	1 x 500 W	1 x 800 W	1 x 1000 W	1 x 1600 W
42NH/NL 4-5	2 x 500 W	2 x 800 W	2 x 1000 W	NA
42NH/NL 4-9	1 x 500 W	1 x 800 W	1 x 1000 W	1 x 1600 W
42NH/NL 5-5	2 x 500 W	2 x 800 W	2 x 1000 W	NA
42NH/NL 5-9	2 x 500 W	2 x 800 W	2 x 1000 W	NA
42NH 6-5	2 x 500 W	2 x 800 W	2 x 1000 W	2 x 1600 W
42NH 6-9	2 x 500 W	2 x 800 W	2 x 1000 W	2 x 1600 W
42NH 7-5	2 x 500 W	2 x 800 W	2 x 1000 W	2 x 1600 W
42NH 7-9	2 x 500 W	3 x 500 W	3 x 800 W	3 x 1000 W

- The heater is protected with a dual safety device:
 - a) Self-holding automatically reset integrated safety thermostat
 - b) Destructive thermofuse link
- Available for 2-pipe coil only.

WARNING: Minimum supply air flow must be maintained to avoid damaging the electric heaters.

A minimum control signal of 3 V is selected by default with Electronic Carrier controller (NTC / WTC). To prevent low air flow with the 42NL range, plenums are not available as an option.

4.2 - Fresh air controller (option)

4.2.1 - Constant volume fresh air controller

The coil can be fitted with a constant fresh air flow controller adjustable from 15 m³/h to 180 m³/h to allow the fresh air intake and the air change rate to be controlled.

The fresh air supply can be located in the air supply plenum, in the air return plenum or in the side of the basic unit casing for a compact design.

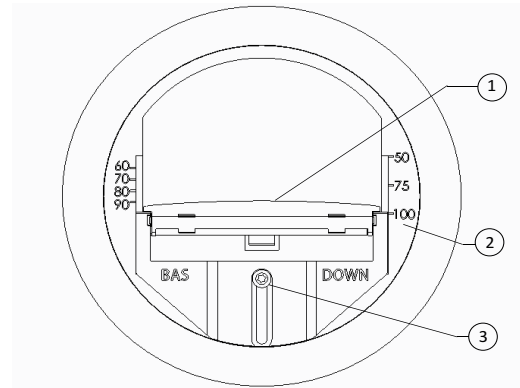
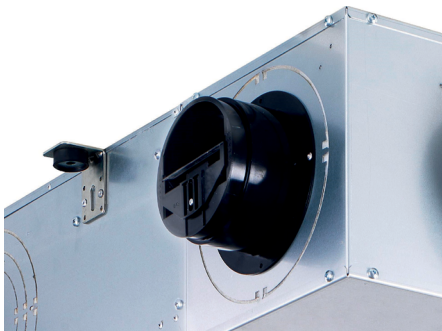

Example: Range 50-100 m³/h

- 1 Air Damper
- 2 Fresh airflow damper position setting (in m³/h)
- 3 Airflow adjustment screw

The fresh air controller may be modified on site by relocating the damper (adjustable screw). Three ranges of air-controller are provided: 15 to 50m³/h, 60 to 100m³/h and 110 to 180m³/h.

IMPORTANT: If an optional return air temperature sensor is provided, the constant fresh air flow rate must not exceed 50 % of the unit supply air flow rate at minimum speed.

NOTE: To operate correctly, the fresh air flow controller requires a differential pressure in the range of 60 Pa to 210 Pa.

4.2.2 - Variable volume fresh air controller

The unit can be equipped with an optional variable fresh air flow controller from 0-55 l/s (0-200 m³/h). It is connected to the numeric Carrier controller and can regulate the fresh air intake in two ways:

- Either using a fixed rate set by the installer that can be reconfigured as required
- Or based on the CO₂ level; in this case it is connected to a CO₂ sensor via the Carrier numeric controller.

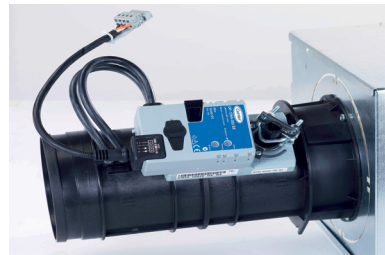

NOTE: With the variable fresh air flow controller the pressure upstream of the fresh air duct must be 180 Pa.

4 - OPTIONS SPECIFICATIONS

4.3 - Valves and actuators (option)

NOTE: The motor/valve assembly is normally closed.

4.3.1 - Valve actuators

A wide choice of actuators is available with two- or four-way valve bodies (three-way with integral bypass) to offer the right solution for any controller type and customer requirement, from on/off to proportional types, with either 230 V or 24 V power supply:

- On/off 230 V actuator
- On/off 24 V actuator
- Floating 3-point 230 V actuator
- Floating 3-point 24 V actuator
- Modulating 0-10 V/24 V actuator

When combined with LEC motors and WTC or NTC controllers, floating 3-point 230 V actuators are recommended to increase energy savings and enhance comfort.

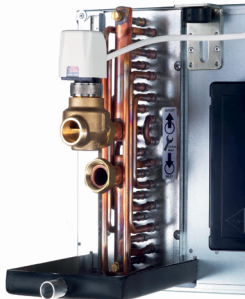
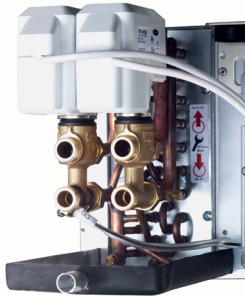

NOTE: 24 V power supply actuators are not compatible with Carrier controllers (Thermostats A/B/C/D, WTC and NTC).

4.3.2 - Standard two-way valve body and three-way valve body (with integral bypass)

Features of the 1/2" two-way and three-way valves for 42NL/NH sizes 2 to 5

- 1/2" male BSP connection for union nuts
- Straight valve body with arrow indicating direction of flow embossed on valve body
- Nominal size DN15 for 1/2" valve
- Nominal pressure: PN 16 bar

Features of the 3/4" two-way and three-way valves for 42NH sizes 6 and 7

- 3/4" male BSP connection for union nuts
- Straight valve body with arrow indicating direction of flow embossed on valve body
- Nominal size DN20 for 3/4" valve
- Nominal pressure: PN 16 bar

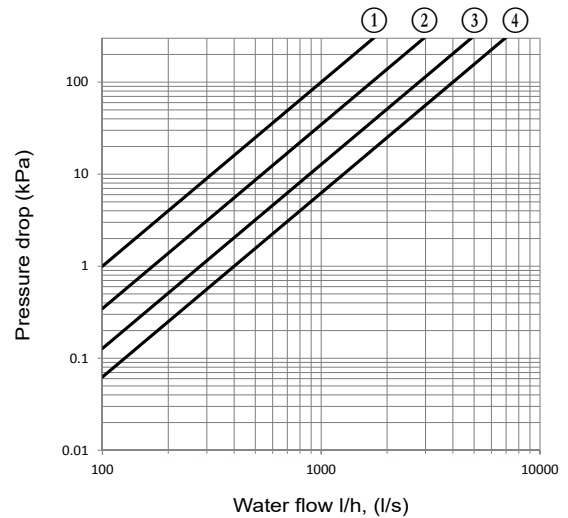

Key

- 1/2" - ON/OFF valve 42NL/NH - Size 2 Kvs = 1
- 1/2" - ON/OFF valve 42NL/NH - Sizes 3, 4, 5 Kvs = 1.7
- 3/4" - ON/OFF valve 42NL/NH - Size 6 Kvs = 2.8
- 3/4" - ON/OFF valve 42NL/NH - Size 7 Kvs = 4

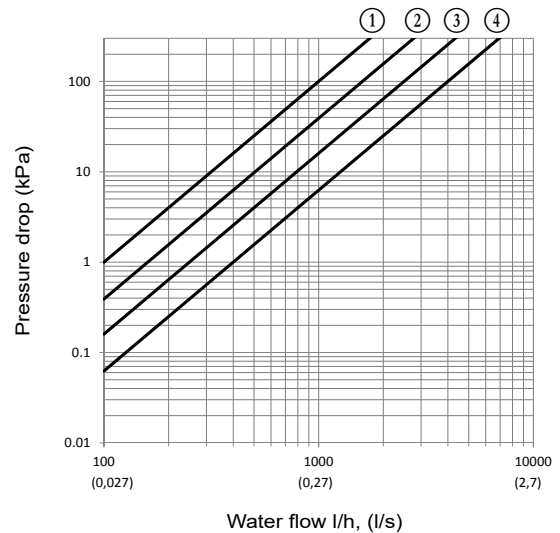

Key

- 1/2" - Modulating valve (3-points & 0-10V) 42NL/NH - Size 2 Kvs = 1
- 1/2" - Modulating valve (3-points & 0-10V) 42NL/NH - Sizes 3, 4, 5 Kvs = 1.6
- 3/4" - Modulating valve (3-points & 0-10V) 42NL/NH - Size 6 Kvs = 2.5
- 3/4" - Modulating valve (3-points & 0-10V) 42NL/NH - Size 7 Kvs = 4

4 - OPTIONS SPECIFICATIONS

4.3.3 - Two way balancing valve body

New two-way valves with embedded balancing function technology are available as an option with 42NH and 42NL units. The Carrier two-way valve with balancing function combines the functionality of a dynamic balancing valve and a control valve in one product.



The dynamic balancing function maintains a constant differential pressure over the control valve.

The control valve regulates the flow by means of a variable orifice which is controlled by the actuator.

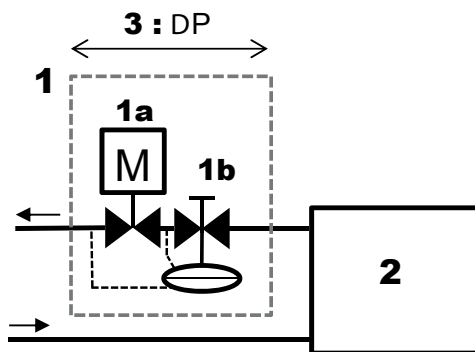

Key

1. Two-way valve with balancing function
 - 1a. Valve actuator for waterflow control
 - 1b. Differential pressure controller & balancing feature
2. Fan-coil unit
3. Minimum operating pressure drop at nominal waterflow: 20 kPa for sizes 4 and 5

The constant differential pressure across the control valve ensures accurate control and maximises valve authority, independently of the pressure conditions in the system.

Advantages compared to the standard two-way valve

- Improved and reliable commissioning. The water flow can be set and controlled on site.
- Higher energy efficiency due to optimal waterflow and maximized valve authority.
- Enhanced comfort thanks to stable and precise ambient temperature control.

Features of the 1" two-way valves with balancing function for 42NL/NH sizes

- 1" male BSP connection for union nuts
- Straight valve body with arrow indicating direction of flow embossed on valve body
- Nominal size DN 20 for 1" valve
- Nominal pressure: PN 16 bar
- Minimum operating differential pressure = 20 kPa at nominal flow.

As a secondary option, two pressure points can be added to the valve body in order to accurately measure the flow rate during the commissioning and maintenance stages.

Sizes	2xx & 3xx	4xx & 5xx
water flow range	100-575 l/h	220 - 1330 l/h
Nominal Diameter	DN15	DN20
Thread	G3/4" for flat washer	G 1" for flat washer

4.4 - Flexible water pipes (option)

4.4.1 - Materials

- Pipes: EPDM-based elastomer (Ethylene Propylene Diene Monomer)
- Braid: 304L stainless steel
- Insulation: cellular foam rubber with M1 fire rating (9 mm thick, flexible water pipes).

4.4.2 - Characteristics

- Minimum bend radius (insulated pipes): 106 mm
- The flexible water pipes are designed for treated or untreated water.
- Maximum operating pressure: 16 bar
- 1/2" female flat gas connections for sizes 2, 3, 4 and 5
- 3/4" female flat gas connections for sizes 6 and 7
- Length: 1 m.

4 - OPTIONS SPECIFICATIONS

4.5 - Sensors (option)

4.5.1 - Water temperature sensor

A water temperature sensor can be provided as an option for NTC and WTC controllers.

- For 2-pipe coil: The sensor is installed on a cooling/heating water pipe (for change-over function).
- For 4-pipe coil: The sensor is installed on a heating water pipe (for cold-draft function that prevents the operation of the unit when the heating network is off).

The fan coil unit is delivered with an electricals box, the "water temperature sensor" option is actually a switch that will be connected to the Carrier thermostat.

NOTE:

- *The water sensor option (switch) with electrical box is only available for 2-pipe coil without electrical heater.*
- *A water probe can also be provided as an accessory only in order to use the cold draft function of the thermostat.*

4.5.2 - Air temperature sensors

Two factory-fitted air temperature sensors are available as an option for NTC and WTC controllers. They measure the temperature at the supply and/or return side.

4.5.3 - CO₂ sensor

For indoor air quality control, a CO₂ sensor is available as an option for NTC and WTC controllers. The sensor is factory fitted at the inlet side.

4.6 - Condensate pump (option)

The condensate pump option is designed to fit on the side of the unit drain pan. Electrical power supply 230V-50/60Hz.

Condensate pump discharge performances:

Sizes 2 to 5 : Water flow rate in litres per hour (-15% / +20%)				
Discharge head	Horizontal length of the discharge pipe			
	5 metres	10 metres	20 metres	30 metres
1 metre	10,4	9,1	8,3	7,3
2 metres	8,5	7,8	7	6,4
3 metres	7,9	7,1	6,3	5,8
4 metres	7	6	5,3	4,9

Size 6 & 7 : Water flow rate in litres per hour (-15% / +20%)				
Discharge head	Horizontal length of the discharge pipe			
	5 metres	10 metres	20 metres	30 metres
1 metre	17	17	16	14
2 metres	14	14	13,5	11,2
3 metres	13	13	12	9,5
4 metres	11,5	10,5	10	8,3

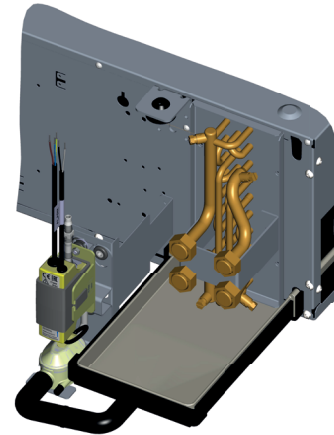

Technical carateristics	Size 2-5	Size 6 & 7
Max. flow rate	10,4 l/h	17 l/h
Max. discharge height	7 m (flow rate 4 l/h)	> 8 m (flow rate 4 l/h)
Maximum pressure	10 m (flow rate 0 l/h)	14 m (flow rate 0 l/h)
Sound level at 1 m as per EN ISO 3744 and 4871 (Measurement taken at LNE, pump in water, outside of application)	20,2 dBA	<28 dBA
Power supply	230V +10%/-15% - 50/60Hz – 19W	230V +10%/-15% - 50/60Hz – 19W
Electrical insulation class	Class 1	Class 1
Detection levels	ON: 14,7 mm, OFF: 10,7 mm, AL: 17 mm	ON: 14,7 mm, OFF: 10,7 mm, AL: 17 mm
Safety switch	BS: 5A resistive – 250V Contacts made from AgNI 90/10, gold-plated	BS: 5A resistive – 250V Contacts made from AgNI 90/10, gold-plated
Heat protection (overheating)	70°C (automatic restart)	70°C (automatic restart)
Operating cycle (duty factor)	100%	100%
Protection (as per BS EN 60529)	IP64	IP64
Safety standard	CE	CE
RoHS directive	Compliant	Compliant
WEEE directive	Compliant	Compliant

5 - CONTROL (OPTION)

The unit can be supplied with a wide range of Carrier controls. These offer functions to suit the various application requirements, summarised in the table below.

	Thermostats	NTC	WTC
Communication protocols			
Carrier Communication Network (CCN) Aquasmart compatible		x	
BACnet MSTP			x
LON			x
Control algorithms			
On-off	x		
Proportional-integral		x	x
Carrier Energy saving algorithm		x	x
Fan control			
3 fixed speeds for AC motors	Types A and B	x	x
Automatic optimum fan speed selection	x	x	x
3 fixed speeds for EC motors	Types C and D	x	x
EC motors Variable speed		x	x
Water valve management			
Air flow control only (no water valve)	x		
230V On-off actuators	x	x	x
230V Modulating actuators (floating 3pts)		x	x
Main functions			
Setpoint control	x	x	x
Occupied/unoccupied mode	x	x	x
Frost protection mode	x	x	x
Window/door contact input	x	x	x
Measurement of water inlet temperature for automatic seasonal changeover (2 pipes)	Type A&C	x	x
Measurement of water inlet temperature to prevent cold-draughts (4 pipes and 2 pipes + electric heater)	Types B and D	x	x
Manual changeover	x	x	x
Frost protection mode	x	x	x
Continuous ventilation within dead-band	x	x	x
Periodical ventilation within dead-band	x	x	x
On-site configuration	x	x	x
Unit grouping Master/Slave	x	x	x
Cassette Louvers control		x	x
Supply air temperature monitoring limiting		x	x
Electrical heater loadshed		x	x
Dirty filter alarm		x	x
Alarm reporting		x	x
Indoor Air Quality control (CO ₂ sensor)		o	o
Demand-controlled ventilation (DCV) (0-10 V fresh air valve)		o	o
Free cooling mode			o
Presence detection			o
User interfaces			
Automatic or manual fan speed control	x	x	x
Setpoint adjustment	x	x	x
Occupancy (eco) button	x	x	o
Digital display		o	o
CO ₂ sensor		o	o
Control kit			
On site control kit solution			o

Key

X Feature available as standard

O Optional

NOTE: For the features and specifications of the Carrier controllers, refer to the technical documentation for each controller.

Upon special request, other controller types can be factory-installed on the units (supplied by Carrier or the customer).

6 - PRODUCT CHARACTERISTICS LIST

Characteristic Name		Digit n° Codification	Value	Description	Pack.	Compatibility		
Range		1-2	42					
		3-4	NH					
			NL					
UNIT SIZE (Digits 5 - 6 - 7)	Chassis size	5	2	Chassis Size 2	Yes	Unit size availability (Digit n° 5-6-7):		
			3	Chassis size 3		2-pipe:	4-pipe:	
			4	Chassis Size 4		NL / NH 225;235;229;239;279	NL / NH 235;239;279	
			5	Chassis Size 5		NL / NH 325;335;329;339	NL / NH 335;339	
			6	Chassis Size 6		NL / NH 425;435;429;439	NL / NH 435;439	
	Efficiency	6	2	Standard efficiency	Yes	NL / NH 525;535;529;539	NL / NH 535;545;539;549	
			3	Medium efficiency		NH 635;645;639;649	NH 645;649	
			4	High efficiency				
	Fan type	7	5	AC multispeed motor	Yes	NH 735;745;739;749	NH 735;745;739;749	
			9	EC low consumption motor				
	Coil hand & type		8	F	2 pipes coil Left Hand	Yes		
				G	2 pipes coil Right Hand			
C				4 pipes coil Left Hand				
D				4 pipes coil Right Hand				
Control		9	-	Bare wires	Yes	Valves and actuators must be selected with NTC		
			E	Electrics box				
			K	NTC				
			L	WTC LON				
			M	WTC BACNET				
Valve body		10	-	Without valve	Yes	Balancing valves are not available for unit sizes 6xx and 7xx		
			G	2-way valve	Yes			
			H	4-way valve	Yes			
			L	2-way balancing valve	No			
			T	2-way balancing valve and pressure points	No			
Electrical heater		11	-	Without electric heater	Yes	Electrical heaters are not compatible with 42NL with plenum.		
			E	500W electric heater		Highest capacity for unit size 2xx		
			F	800W electric heater		Highest capacity for unit sizes 3xx and 4x9		
			G	1000W electric heater		Highest capacity for unit sizes 4x5 and 5xx		
			H	1500W electric heater		Highest capacity for unit sizes 7x9		
			J	1600W electric heater		Highest capacity for unit sizes 6xx and 7x5		
			K	2000W electric heater				
			L	2400W electric heater				
			M	3000W electric heater				
			N	3200W electric heater				
Valve actuator		12	-	Without actuator	Yes	24 V actuators are not available with Carrier controllers. 3-point floating actuators are not available with the electrics box		
			A	230V ON/OFF actuator	Yes			
			C	230V floating actuator (3 points)	No			
			B	24V ON/OFF actuator	Yes			
			D	24V floating actuator (3 points)	No			
			E	24V 0-10V modulating actuator	No			
Rectangular flanges		13	-	Without rectangular flange	Yes			
			A	Outlet rectangular flange only	Yes			
			B	Inlet rectangular flange only	Yes			
			C	Inlet and outlet rectangular flanges	Yes			
Specific (options selection)		14	-	Without specific option	Yes			
			A	With specific options (factory fitted)	Yes			

Key:

Default value for mandatory characteristic

Pack: Available with individual packaging

6 - PRODUCT CHARACTERISTICS LIST

Specific options (can be selected if digit no. 14 = A*)

Characteristic Name	Value	Description	Pack.	Compatibility
Indoor air quality	Without	Filter	Yes	Only available with rect. flanges or plenum
	G3		Yes	
	M5		No	M5 filter only available for 42NH units with plenum
Fan speed wiring for AC motor	654	AC motor speeds arrangement: R6 = minimum speed for 42NL R5 = minimum speed for 42NH R1 = maximum speed When this option is not selected, the standard wiring for all 42NL and 42NH units is always R5-R3-R1	Yes	R6 not available for 42NH range
	653			
	652			
	651			
	643			
	642			
	641			
	632			
	631			
	621			
	543			
	542			
	541			
	532			
	531			
521				
432				
431				
421				
321				
Packaging	Bundle	Filmed on a pallet (shrink wrap)	-	
	Individual	Individual packaging		
Inlet plenum	1_inline	1 spigot in line	No	According to unit sizes, filter and fresh air position Use selection software for more informations
	1_lat_op	1 lateral spigot opposite to coil side		
	1_lat	1 lateral spigot at coil side		
	2	2 spigots		
	2_lat	2 lateral spigots		
	3	3 spigots		
	4	4 spigots		
	5	5 spigots		
6	6 spigots			
7	7 spigots			
Outlet plenum	1_inline	1 spigot in line	No	According to unit sizes, filter and fresh air position Use selection software for more informations
	1_lat_op	1 lateral spigot opposite to coil side		
	1_lat	1 lateral spigot at coil side		
	2	2 spigots		
	2_lat	2 lateral spigots		
	3	3 spigots		
	4	4 spigots		
5	5 spigots			
6	6 spigots			

Key:
 Default value for mandatory characteristic
 Pack: Available with individual packaging

* If digit no. 14 = "-" the default values are selected.
 Boolean: yes or no

6 - PRODUCT CHARACTERISTICS LIST

Characteristic Name	Value	Description	Pack.	Compatibility
Inlet spigots diameter	DN160	Spigot diameter	No	DN160 Not available for unit sizes 6xx to 7xx
	DN200			DN250 Not available for unit sizes 2xx to 5xx
	DN250			
Outlet spigots diameter	DN160	Spigot diameter	No	DN160 Not available for unit sizes 6xx to 7xx
	DN200			DN250 Not available for unit sizes 2xx to 5xx
	DN250			
Fresh air	DN125	Without controller - spigot only	No	Motorized air damper compatible with NTC and WTC only (Position feedback is not available if WTC and CO ₂ sensor are also selected)
	DN125_15_50	15 to 50 m ³ /h controller		
	DN125_50_100	50 to 100 m ³ /h controller		
	DN125_100_180	100 to 180 m ³ /h controller		
	Adaptor_D125	For motorized air damper (to be ordered separately)		
Fresh air position	In_opp	At inlet side opposite to coil hand	No	According to unit sizes, filter and spigots selection Use selection software for more informations
	In_coil	At inlet side same as coil hand		
	In_line	At inlet rear side		
	Optimized	Inlet optimized: opposite to coil hand in base unit for compact design		
	Out_opp	At outlet side opposite to coil hand		
	Out_coil	At outlet side same as coil hand		
Fuse holder	boolean	Fuse holder	Yes	
Plastic cover	boolean	Plastic cover	Yes	For bare wires (without control only)
Condensate pump	boolean	Condensate pump	No	
Flexible	boolean	Flexible hoses	No	
Return air sensor	boolean	Return air temperature sensor	Yes	Compatible with NTC and WTC only
Supply air sensor	boolean	Supply air temperature sensor	Yes	Compatible with NTC and WTC only
Water temperature sensor	boolean	Water temperature sensor	Yes	According to controller and coil type
CO₂ sensor	boolean	CO ₂ sensor	Yes	Compatible with NTC and WTC only

Key:

Pack: Available with individual packaging

* If digit no. 14 = "-" the default values are selected.

Boolean: yes or no

7 - 42NH AND 42NL PERFORMANCE DATA

7.1 - Physical and electrical data at Eurovent conditions - 42NL - Sizes 2 and 3

With G3 filter - without plenum

42NL	225						235						
	R6	R5	R4	R3	R2	R1	R6	R5	R4	R3	R2	R1	
Fan speed													
(Eurovent certification speeds)	(L)	(M)	(H)			(Max)	(L)	(M)	(H)			Max	
Air flow	l/s	59	69	96	109	125	138	59	69	96	109	125	138
	m ³ /h	214	248	346	393	449	496	214	248	346	393	449	496
Available static pressure	Pa	0	0	0	0	0	0	0	0	0	0	0	0
Cooling mode, two pipes⁽¹⁾													
Total cooling capacity	kW	1,17	1,33	1,72	1,87	2,03	2,13	1,35	1,54	2,04	2,25	2,46	2,62
Sensible cooling capacity	kW	0,93	1,06	1,40	1,54	1,69	1,80	1,03	1,18	1,59	1,76	1,96	2,10
Water flow	l/s	0,06	0,06	0,08	0,09	0,10	0,11	0,07	0,08	0,10	0,11	0,12	0,13
	l/h	210	230	300	330	360	380	240	270	360	400	430	460
Water pressure drop	kPa	16,2	20,4	31,4	36,5	42	46,3	12,2	15,6	26,5	31	36,3	40,7
Water volume	l	0,4						0,5					
Heating mode, two pipes⁽²⁾													
Heating capacity	kW	1,39	1,58	2,07	2,28	2,50	2,68	1,57	1,80	2,41	2,69	2,99	3,23
Water flow	l/s	0,07	0,08	0,10	0,11	0,12	0,13	0,08	0,09	0,12	0,13	0,14	0,16
	l/h	240	270	360	400	440	470	270	310	420	470	520	560
Water pressure drop	kPa	17,9	22,1	35	41,3	48,6	54,7	13,9	17,3	28,4	34,2	41	46,8
Water volume	l	0,4						0,5					
Cooling mode, four pipes⁽¹⁾													
Total cooling capacity	kW	NA						1,02	1,16	1,51	1,65	1,80	1,90
Sensible cooling capacity	kW	NA						0,86	0,98	1,30	1,44	1,58	1,69
Water flow	l/s	NA						0,05	0,06	0,08	0,08	0,09	0,09
	l/h	NA						180	200	270	290	320	340
Water pressure drop	kPa	NA						5,4	6,6	10,5	12,4	14,6	16,4
Water volume	l	NA						0,3					
Heating mode, four pipes⁽³⁾													
Heating capacity	kW	NA						1,63	1,84	2,36	2,56	2,76	2,91
Water flow	l/s	NA						0,04	0,04	0,06	0,06	0,07	0,07
	l/h	NA						140	160	210	220	240	260
Water pressure drop	kPa	NA						4,8	5,7	8,3	9,5	10,7	11,6
Water volume	l	NA						0,2					
Electric heater		230V ±10% - 1ph - 50Hz						230V ±10% - 1ph - 50Hz					
Maximum capacity	W	1000						1000					
Current input	A	4,6						4,6					
Sound levels													
Sound power level (global)	dB(A)	38	41	48	51	54	57	38	41	48	51	54	57
Electrical data, motor													
Power input	W	28	31	45	54	65	80	28	31	45	54	65	80
Current input	A	0,12	0,14	0,20	0,23	0,28	0,35	0,12	0,14	0,20	0,23	0,28	0,35
FCEER [energy class] - 2 pipes		42 [E]						48 [E]					
FCCOP [energy class]		50 [E]						56 [E]					
FCEER [energy class] - 4 pipes								37 [E]					
FCCOP [energy class]								58 [E]					

Fan speed: L = Low, M = Medium, H = High



Eurovent certified values

- (1) Eurovent conditions: inlet air temperature = 27 °C db/47 % RH – water inlet temperature = 7 °C, water temperature difference = 5 K.
 (2) Eurovent conditions: inlet air temperature = 20 °C, water inlet temperature = 50 °C, water flow identical to cooling mode.
 (3) Eurovent conditions: inlet air temperature = 20 °C, water inlet temperature = 70 °C, water temperature difference = 10K.

7 - 42NH AND 42NL PERFORMANCE DATA

42NL	229				239				
Fan speed	2V	4V	6V	10V	2V	5V	7V	10V	
(Eurovent certification speeds)	(L)	(M)	(H)	Max	(L)	(M)	(H)	(Max)	
Air flow	43	58	73	102	43	65	81	102	
	l/s								
	m ³ /h	153	210	261	368	153	234	368	
Available static pressure	Pa	0	0	0	0	0	0	0	
Cooling mode, two pipes⁽¹⁾									
Total cooling capacity	kW	0,89	1,17	1,41	1,83	1,00	1,48	1,81	2,17
Sensible cooling capacity	kW	0,70	0,94	1,14	1,50	0,76	1,14	1,40	1,71
Water flow	l/s	0,04	0,06	0,07	0,09	0,05	0,07	0,09	0,11
	l/h	150	200	240	320	170	260	310	380
Water pressure drop	kPa	9,4	15,7	22,1	33,8	7	14,1	20,3	28,7
Water volume	l	0,4				0,5			
Heating mode, two pipes⁽²⁾									
Heating capacity	kW	1,03	1,37	1,65	2,17	1,13	1,70	2,08	2,55
Water flow	l/s	0,05	0,07	0,08	0,11	0,06	0,08	0,10	0,12
	l/h	180	240	290	380	200	300	360	440
Water pressure drop	kPa	11	17,5	23,8	37,9	8,3	15,8	22,2	31,1
Water volume	l	0,4				0,5			
Cooling mode, four pipes⁽¹⁾									
Total cooling capacity	kW	NA				0,76	1,12	1,35	1,61
Sensible cooling capacity	kW	NA				0,65	0,96	1,16	1,40
Water flow	l/s	NA				0,04	0,05	0,06	0,08
	l/h	NA				130	190	230	280
Water pressure drop	kPa	NA				3,4	6,1	8,3	11,4
Water volume	l	NA				0,3			
Heating mode, four pipes⁽³⁾									
Heating capacity	kW	NA				1,21	1,75	2,09	2,46
Water flow	l/s	NA				0,03	0,04	0,05	0,06
	l/h	NA				110	150	180	220
Water pressure drop	kPa	NA				3,3	5,4	6,9	8,9
Water volume	l	NA				0,2			
Electric heater		230V ±10% - 1ph - 50Hz				230V ±10% - 1ph - 50Hz			
Maximum capacity	W	1000				1000			
Current input	A	4,6				4,6			
Sound levels									
Sound power level (global)	dB(A)	32	37	40	48	32	38	41	48
Electrical data, motor									
Power input	W	3	5	7	13	3	5	9	13
Current input	A	0,05	0,06	0,08	0,14	0,05	0,06	0,10	0,14
FCEER [energy class] - 2 pipes		263 [A]				304 [A]			
FCCOP [energy class]		310 [A]				347 [A]			
FCEER [energy class] - 4 pipes						230 [A]			
FCCOP [energy class]						366 [A]			

Fan speed: L = Low, M = Medium, H = High



Eurovent certified values

- (1) Eurovent conditions: inlet air temperature = 27 °C db/47 % RH – water inlet temperature = 7 °C, water temperature difference = 5 K.
 (2) Eurovent conditions: inlet air temperature = 20 °C, water inlet temperature = 50 °C, water flow identical to cooling mode.
 (3) Eurovent conditions: inlet air temperature = 20 °C, water inlet temperature = 70 °C, water temperature difference = 10K.

7 - 42NH AND 42NL PERFORMANCE DATA

42NL	325						335						
Fan speed	R6	R5	R4	R3	R2	R1	R6	R5	R4	R3	R2	R1	
(Eurovent certification speeds)	(L)	(M)	(H)			(Max)	(L)	(M)	(H)			(Max)	
Air flow	l/s	84	94	124	144	154	168	84	94	124	144	154	168
	m ³ /h	302	338	447	517	555	606	302	338	447	517	555	606
Available static pressure	Pa	0	0	0	0	0	0	0	0	0	0	0	0
Cooling mode, two pipes⁽¹⁾													
Total cooling capacity	kW	1,43	1,56	1,90	2,11	2,20	2,33	1,75	1,94	2,48	2,80	2,95	3,16
Sensible cooling capacity	kW	1,21	1,32	1,65	1,84	1,94	2,06	1,38	1,54	1,98	2,24	2,38	2,56
Water flow	l/s	0,07	0,08	0,09	0,11	0,11	0,12	0,09	0,09	0,12	0,14	0,14	0,16
	l/h	250	270	340	380	390	420	310	340	440	490	520	560
Water pressure drop	kPa	10,5	12,2	17,9	21,3	23,1	25,6	11,6	13,9	22	27,5	30,3	33,8
Water volume	l	0,7						0,9					
Heating mode, two pipes⁽²⁾													
Heating capacity	kW	1,97	2,16	2,67	2,96	3,10	3,27	2,23	2,48	3,17	3,57	3,77	4,02
Water flow	l/s	0,09	0,11	0,13	0,14	0,15	0,16	0,11	0,12	0,15	0,17	0,18	0,19
	l/h	340	380	460	510	540	570	390	430	550	620	660	700
Water pressure drop	kPa	17,9	20,6	28,6	33,6	36,2	39,5	15,3	18,1	27,2	33,3	36,6	40,9
Water volume	l	0,7						0,9					
Cooling mode, four pipes⁽¹⁾													
Total cooling capacity	kW	NA						1,75	1,91	2,35	2,60	2,73	2,88
Sensible cooling capacity	kW	NA						1,37	1,50	1,88	2,10	2,21	2,36
Water flow	l/s	NA						0,09	0,09	0,11	0,13	0,13	0,14
	l/h	NA						310	340	410	460	480	510
Water pressure drop	kPa	NA						15,9	18,8	26,9	32	34,7	38,3
Water volume	l	NA						0,6					
Heating mode, four pipes⁽³⁾													
Heating capacity	kW	NA						2,43	2,66	3,21	3,48	3,61	3,78
Water flow	l/s	NA						0,06	0,06	0,08	0,09	0,09	0,09
	l/h	NA						210	230	280	310	320	330
Water pressure drop	kPa	NA						11	12,6	17,2	19,7	20,9	22,5
Water volume	l	NA						0,3					
Electric heater													
		230V ±10% - 1ph - 50Hz						230V ±10% - 1ph - 50Hz					
Maximum capacity	W	1600						1600					
Current input	A	7,3						7,3					
Sound levels													
Sound power level (global)	dB(A)	43	46	54	57	59	61	43	46	54	57	59	61
Electrical data, motor													
Power input	W	38	45	62	74	86	99	38	45	62	74	86	99
Current input	A	0,16	0,20	0,27	0,32	0,37	0,44	0,16	0,20	0,27	0,32	0,37	0,44
FCEER [energy class] - 2 pipes		36 [E]						45 [E]					
FCCOP [energy class]		50 [E]						57 [E]					
FCEER [energy class] - 4 pipes								44 [E]					
FCCOP [energy class]								62 [E]					

Fan speed: L = Low, M = Medium, H = High



Eurovent certified values

(1) Eurovent conditions: inlet air temperature = 27 °C db/47 % RH – water inlet temperature = 7 °C, water temperature difference = 5 K.

(2) Eurovent conditions: inlet air temperature = 20 °C, water inlet temperature = 50 °C, water flow identical to cooling mode.

(3) Eurovent conditions: inlet air temperature = 20 °C, water inlet temperature = 70 °C, water temperature difference = 10K.

7 - 42NH AND 42NL PERFORMANCE DATA

42NL	329				339						
Fan speed	2V	4V	6V	10V	2V	5V	7V	10V			
(Eurovent certification speeds)	(L)	(M)	(H)	(Max)	(L)	(M)	(H)	(Max)			
Air flow	55	88	120	165	55	88	120	165			
	l/s										
	198	318	431	594	198	318	431	594			
	m ³ /h										
Available static pressure	0	0	0	0	0	0	0	0			
	Pa										
Cooling mode, two pipes⁽¹⁾											
Total cooling capacity	1,05	1,52	1,89	2,35	1,21	1,87	2,44	3,16			
	kW										
Sensible cooling capacity	0,87	1,29	1,64	2,08	0,95	1,48	1,95	2,56			
	kW										
Water flow	0,05	0,07	0,09	0,11	0,06	0,09	0,12	0,15			
	l/s										
	180	260	330	410	210	320	420	550			
	l/h										
Water pressure drop	5,9	11,2	17	25	5,9	12,6	20,7	32,9			
	kPa										
Water volume	0,7				0,9						
	l										
Heating mode, two pipes⁽²⁾											
Heating capacity	1,37	2,05	2,60	3,23	1,50	2,34	3,06	3,96			
	kW										
Water flow	0,07	0,10	0,13	0,16	0,07	0,11	0,15	0,19			
	l/s										
	240	360	450	560	260	410	530	690			
	l/h										
Water pressure drop	10,9	19,1	27,3	38,7	8,2	16,5	25,7	39,8			
	kPa										
Water volume	0,7				0,9						
	l										
Cooling mode, four pipes⁽¹⁾											
Total cooling capacity	NA				1,27	1,87	2,36	2,95			
					kW						
Sensible cooling capacity					0,98	1,47	1,89	2,43			
					kW						
Water flow					0,06	0,09	0,11	0,14			
	l/s										
	220	320	400	510							
	l/h										
Water pressure drop	8	16	25	37							
	kPa										
Water volume	0,5984										
	l										
Heating mode, four pipes⁽³⁾											
Heating capacity	NA				1,95	2,90	3,58	4,27			
					kW						
Water flow					0,05	0,07	0,09	0,11			
					l/s						
					170	250	310	380			
	l/h										
Water pressure drop	7	13	19	26							
	kPa										
Water volume	0,3										
	l										
Electric heater											
	230V ±10% - 1ph - 50Hz				230V ±10% - 1ph - 50Hz						
Maximum capacity	1600				1600						
	W										
Current input	7,3				7,3						
	A										
Sound levels											
Sound power level (global)	37	46	53	60	37	46	53	60			
	dB(A)										
Electrical data, motor											
Power input	4	10	20	49	4	10	20	49			
	W										
Current input	0,06	0,10	0,17	0,39	0,06	0,10	0,17	0,39			
	A										
FCEER [energy class] - 2 pipes	187 [A]				223 [A]						
FCCOP [energy class]	254 [B]				284 [A]						
FCEER [energy class] - 4 pipes					228 [A]						
FCCOP [energy class]					360 [A]						

Fan speed: L = Low, M = Medium, H = High



Eurovent certified values

- (1) Eurovent conditions: inlet air temperature = 27 °C db/47 % RH – water inlet temperature = 7 °C, water temperature difference = 5 K.
 (2) Eurovent conditions: inlet air temperature = 20 °C, water inlet temperature = 50 °C, water flow identical to cooling mode.
 (3) Eurovent conditions: inlet air temperature = 20 °C, water inlet temperature = 70 °C, water temperature difference = 10K.

7 - 42NH AND 42NL PERFORMANCE DATA

7.2 - Physical and electrical data at Eurovent conditions - 42NL - Size 4

With G3 filter - without plenum

42NL	425						435						
	R6	R5	R4	R3	R2	R1	R6	R5	R4	R3	R2	R1	
Fan speed													
(Eurovent certification speeds)	(L)	(M)	(H)			(Max)	(L)	(M)	(H)			(Max)	
Air flow	l/s	129	149	209	234	267	301	129	149	209	234	267	301
	m ³ /h	464	537	751	842	960	1085	464	537	751	842	960	1085
Available static pressure	Pa	0	0	0	0	0	0	0	0	0	0	0	0
Cooling mode, two pipes⁽¹⁾													
Total cooling capacity	kW	2,37	2,67	3,44	3,70	4,01	4,26	2,69	3,12	4,25	4,67	5,15	5,59
Sensible cooling capacity	kW	1,93	2,19	2,87	3,13	3,43	3,70	2,12	2,45	3,35	3,70	4,13	4,53
Water flow	l/s	0,12	0,13	0,17	0,18	0,20	0,21	0,13	0,15	0,21	0,23	0,25	0,28
	l/h	420	470	610	660	710	760	470	550	750	820	910	990
Water pressure drop	kPa	14,8	18,5	28,3	32,2	36,8	41,2	19,4	25,7	43,7	51,3	60,8	70,2
Water volume	l	1,0						1,3					
Heating mode, two pipes⁽²⁾													
Heating capacity	kW	2,95	3,40	4,61	5,07	5,60	6,09	3,15	3,64	5,04	5,60	6,29	6,97
Water flow	l/s	0,14	0,16	0,22	0,24	0,27	0,29	0,15	0,18	0,24	0,27	0,30	0,34
	l/h	510	590	800	880	970	1060	550	630	880	970	1090	1210
Water pressure drop	kPa	17,70	22,40	37,50	44,10	52,30	60,50	21,70	27,80	48,20	57,90	70,90	84,70
Water volume	l	1,0						1,3					
Cooling mode, four pipes⁽¹⁾													
Total cooling capacity	kW	NA						2,46	2,77	3,58	3,88	4,23	4,56
Sensible cooling capacity	kW	NA						1,99	2,25	2,97	3,25	3,58	3,90
Water flow	l/s	NA						0,12	0,14	0,18	0,19	0,21	0,23
	l/h	NA						430	490	630	690	750	810
Water pressure drop	kPa	NA						20,1	24,9	38,5	44,2	51,3	58,7
Water volume	l	NA						0,9					
Heating mode, four pipes⁽³⁾													
Heating capacity	kW	NA						3,17	3,68	5,01	5,50	6,05	6,54
Water flow	l/s	NA						0,08	0,09	0,12	0,13	0,15	0,16
	l/h	NA						280	320	440	480	530	570
Water pressure drop	kPa	NA						18,9	24,3	41,2	48,4	57,1	65,4
Water volume	l	NA						0,5					
Electric heater													
		230V ±10% - 1ph - 50Hz						230V ±10% - 1ph - 50Hz					
Maximum capacity	W	2000						2000					
Current input	A	9,1						9,1					
Sound levels													
Sound power level (global)	dB(A)	45	48	55	58	60	63	45	48	55	58	60	63
Electrical data, motor													
Power input	W	57	69	98	113	129	157	57	69	98	113	129	157
Current input	A	0,25	0,30	0,43	0,49	0,57	0,69	0,25	0,30	0,43	0,49	0,57	0,69
FCEER [energy class] - 2 pipes		40 [E]						46 [E]					
FCCOP [energy class]		51 [E]						54 [E]					
FCEER [energy class] - 4 pipes								42 [E]					
FCCOP [energy class]								55 [E]					

Fan speed: L = Low, M = Medium, H = High



Eurovent certified values

- (1) Eurovent conditions: inlet air temperature = 27 °C db/47 % RH – water inlet temperature = 7 °C, water temperature difference = 5 K.
 (2) Eurovent conditions: inlet air temperature = 20 °C, water inlet temperature = 50 °C, water flow identical to cooling mode.
 (3) Eurovent conditions: inlet air temperature = 20 °C, water inlet temperature = 70 °C, water temperature difference = 10K.

7 - 42NH AND 42NL PERFORMANCE DATA

42NL	429						439						
Fan speed	2V	3.5V	4V	6V	8V	10V	2V	3.5V	4V	6V	8V	10V	
(Eurovent certification speeds)	(L)	(M)	(H)			(Max)	(L)	(M)	(H)			(Max)	
Air flow	l/s	67	110	123	169	206	226	67	111	123	169	206	226
	m ³ /h	240	397	444	610	743	814	240	398	444	610	743	814
Available static pressure	Pa	0	0	0	0	0	0	0	0	0	0	0	0
Cooling mode, two pipes⁽¹⁾													
Total cooling capacity	kW	1,33	2,09	2,31	2,99	3,43	3,63	1,34	2,32	2,60	3,56	4,22	4,54
Sensible cooling capacity	kW	1,08	1,71	1,89	2,47	2,87	3,06	1,09	1,84	2,05	2,80	3,33	3,60
Water flow	l/s	0,06	0,10	0,11	0,14	0,17	0,18	0,06	0,11	0,13	0,17	0,21	0,22
	l/h	230	360	400	520	600	640	230	400	450	620	740	800
Water pressure drop	kPa	5,3	11,5	13,8	21,9	27,9	31	5,4	14,3	17,7	32,2	42,9	48,8
Water volume	l	1,0						1,3					
Heating mode, two pipes⁽²⁾													
Heating capacity	kW	1,49	2,52	2,82	3,83	4,57	4,93	1,59	2,68	3,00	4,12	4,98	5,42
Water flow	l/s	0,07	0,12	0,14	0,19	0,22	0,24	0,08	0,13	0,14	0,20	0,24	0,26
	l/h	260	440	490	670	800	860	280	470	520	720	870	940
Water pressure drop	kPa	6,1	13,6	16,4	27,3	36,9	42,0	7,3	16,7	20,1	34,2	47,3	54,7
Water volume	l	1,0						1,3					
Cooling mode, four pipes⁽¹⁾													
Total cooling capacity	kW	NA						1,40	2,18	2,40	3,09	3,57	3,79
Sensible cooling capacity	kW	NA						1,11	1,76	1,94	2,54	2,96	3,17
Water flow	l/s	NA						0,07	0,11	0,11	0,15	0,18	0,19
	l/h	NA						240	380	410	540	630	670
Water pressure drop	kPa	NA						7,0	15,6	18,6	29,6	37,9	42,3
Water volume	l	NA						0,9					
Heating mode, four pipes⁽³⁾													
Heating capacity	kW	NA						1,50	2,68	3,02	4,15	4,96	5,35
Water flow	l/s	NA						0,04	0,07	0,07	0,10	0,12	0,13
	l/h	NA						130	240	260	360	430	470
Water pressure drop	kPa	NA						5,9	14,4	17,5	29,8	40,5	46,1
Water volume	l	NA						0,5					
Electric heater													
		230V ±10% - 1ph - 50Hz						230V ±10% - 1ph - 50Hz					
Maximum capacity	W	1600						1600					
Current input	A	7,3						7,3					
Sound levels													
Sound power level (global)	dB(A)	38	49	52	60	65	67	38	49	52	60	65	67
Electrical data, motor													
Power input	W	6	15	18	42	78	99	6	14	18	42	78	99
Current input	A	0,07	0,15	0,18	0,38	0,65	0,80	0,07	0,15	0,18	0,38	0,65	0,80
FCEER [energy class] - 2 pipes		173 [B]						189 [A]					
FCCOP [energy class]		205 [B]						225 [B]					
FCEER [energy class] - 4 pipes								187 [A]					
FCCOP [energy class]								218 [B]					

Fan speed: L = Low, M = Medium, H = High



Eurovent certified values

- (1) Eurovent conditions: inlet air temperature = 27 °C db/47 % RH – water inlet temperature = 7 °C, water temperature difference = 5 K.
(2) Eurovent conditions: inlet air temperature = 20 °C, water inlet temperature = 50 °C, water flow identical to cooling mode.
(3) Eurovent conditions: inlet air temperature = 20 °C, water inlet temperature = 70 °C, water temperature difference = 10K.

7 - 42NH AND 42NL PERFORMANCE DATA

7.3 - Physical and electrical data at Eurovent conditions - 42NL - Size 5

With G3 filter - without plenum

42NL	525						535						545												
Fan speed	R6	R5	R4	R3	R2	R1	R6	R5	R4	R3	R2	R1	R6	R5	R4	R3	R2	R1							
(Eurovent certification speeds)	(L)		(M)	(H)		(Max)	(L)		(M)	(H)		(Max)	(L)		(M)	(H)		(Max)							
Air flow	l/s		150	170	233	275	313	359	l/s		150	170	233	275	313	359	l/s		150	170	233	275	313	359	
	m ³ /h		540	612	840	991	1127	1291	m ³ /h		540	612	840	991	1127	1291	m ³ /h		540	612	840	991	1127	1291	
Available static pressure	Pa	0	0	0	0	0	0	0	Pa	0	0	0	0	0	0	0	0	0	Pa	0	0	0	0	0	0
Cooling mode, two pipes⁽¹⁾																									
Total cooling capacity	kW		2,69	2,97	3,78	4,23	4,61	5,00	kW		3,14	3,54	4,68	5,32	5,80	6,30	kW		3,14	3,54	4,68	5,32	5,80	6,30	
Sensible cooling capacity	kW		2,21	2,46	3,17	3,59	3,95	4,34	kW		2,47	2,78	3,71	4,26	4,70	5,18	kW		2,47	2,78	3,71	4,26	4,70	5,18	
Water flow	l/s		0,13	0,14	0,19	0,21	0,23	0,25	l/s		0,15	0,17	0,23	0,26	0,28	0,31	l/s		0,15	0,17	0,23	0,26	0,28	0,31	
	l/h		470	520	670	750	810	890	l/h		550	620	820	930	1020	1110	l/h		550	620	820	930	1020	1110	
Water pressure drop	kPa		16,8	20,3	31,3	37,9	43,9	50,8	kPa		21	26,4	43,7	54	62,9	72,7	kPa		21	26,4	43,7	54	62,9	72,7	
Water volume	l		1,4						1,8						NA										
Heating mode, two pipes⁽²⁾																									
Heating capacity	kW		3,45	3,87	5,08	5,75	6,27	6,80	kW		3,56	4,04	5,41	6,14	6,68	7,18	kW		3,56	4,04	5,41	6,14	6,68	7,18	
Water flow	l/s		0,17	0,19	0,24	0,28	0,30	0,33	l/s		0,17	0,19	0,26	0,30	0,32	0,35	l/s		0,17	0,19	0,26	0,30	0,32	0,35	
	l/h		600	670	880	1000	1090	1180	l/h		620	700	940	1070	1160	1250	l/h		620	700	940	1070	1160	1250	
Water pressure drop	kPa		21,6	26,1	41,5	51,3	59,5	68,6	kPa		25,3	31,3	51,4	64	74	83,8	kPa		25,3	31,3	51,4	64	74	83,8	
Water volume	l		1,4						1,8						NA										
Cooling mode, four pipes⁽¹⁾																									
Total cooling capacity	kW		NA						kW		2,70	3,00	3,86	4,33	4,71	5,11	kW		2,92	3,27	4,32	4,93	5,44	5,98	
Sensible cooling capacity	kW		NA						kW		2,20	2,45	3,19	3,62	3,98	4,37	kW		2,35	2,64	3,51	4,04	4,49	4,99	
Water flow	l/s		NA						l/s		0,13	0,15	0,19	0,21	0,23	0,25	l/s		0,14	0,16	0,21	0,24	0,27	0,29	
	l/h		NA						l/h		470	530	680	760	830	910	l/h		510	570	760	870	960	1060	
Water pressure drop	kPa		NA						kPa		17,9	22	34,3	41,8	48,3	55,8	kPa		18	22,4	37,4	47	55,5	65,6	
Water volume	l		NA						1,1						1,4										
Heating mode, four pipes⁽³⁾																									
Heating capacity	kW		NA						kW		2,99	3,29	4,14	4,60	4,95	5,32	kW		3,44	3,86	5,00	5,57	5,96	6,31	
Water flow	l/s		NA						l/s		0,07	0,08	0,10	0,11	0,12	0,13	l/s		0,08	0,09	0,12	0,14	0,14	0,15	
	l/h		NA						l/h		260	290	360	400	430	470	l/h		300	340	440	490	520	550	
Water pressure drop	kPa		NA						kPa		5,9	6,8	9,6	11,4	12,8	14,4	kPa		6,8	8,1	12,1	14,3	16	17,6	
Water volume	l		NA						0,5						0,6										
Electric heater	230V ±10% - 1ph - 50Hz						230V ±10% - 1ph - 50Hz						230V ±10% - 1ph - 50Hz												
Maximum capacity	W						2000						2000												
Current input	A						9,1						9,1												
Sound levels																									
Sound power level (global)	dB(A)		42	46	53	57	59	62	dB(A)		42	46	53	57	59	62	dB(A)		42	46	53	57	59	62	
Electrical data, motor																									
Power input	W		58	67	99	118	137	170	W		58	67	99	118	137	170	W		58	67	99	118	137	170	
Current input	A		0,26	0,30	0,43	0,52	0,60	0,74	A		0,26	0,30	0,43	0,52	0,60	0,74	A		0,26	0,30	0,43	0,52	0,60	0,74	
FCEER [energy class] - 2 pipes	42 [E]						51 [E]						NA												
FCCOP [energy class]	56 [E]						58 [E]						NA												
FCEER [energy class] - 4 pipes	NA						43 [E]						47 [E]												
FCCOP [energy class]	NA						47 [E]						55 [E]												

Fan speed: L = Low, M = Medium, H = High



Eurovent certified values

- (1) Eurovent conditions: inlet air temperature = 27 °C db/47 % RH – water inlet temperature = 7 °C, water temperature difference = 5 K.
- (2) Eurovent conditions: inlet air temperature = 20 °C, water inlet temperature = 50 °C, water flow identical to cooling mode.
- (3) Eurovent conditions: inlet air temperature = 20 °C, water inlet temperature = 70 °C, water temperature difference = 10K.

7 - 42NH AND 42NL PERFORMANCE DATA

42NL	529						539						549						
Fan speed	2V	4V	5V	6V	8V	10V	2V	4V	5.5V	6V	8V	10V	2V	4V	5.5V	6V	8V	10V	
(Eurovent certification speeds)	(L)		(M)	(H)		(Max)	(L)		(M)	(H)		(Max)	(L)		(M)	(H)		(Max)	
Air flow	l/s	82	141	172	188	231	255	82	141	179	187	230	254	81	140	179	187	230	254
	m ³ /h	294	508	618	675	831	918	294	507	645	673	828	915	290	505	644,5	674	829	916
Available static pressure	Pa	0	0	0	0	0	0	0	0	0	0	0	0	0	0	0	0	0	0
Cooling mode, two pipes⁽¹⁾																			
Total cooling capacity	kW	1,65	2,60	3,04	3,26	3,80	4,06	1,70	2,99	3,78	3,93	4,69	5,06	NA					
Sensible cooling capacity	kW	1,33	2,14	2,52	2,71	3,19	3,44	1,36	2,36	2,98	3,10	3,72	4,04						
Water flow	l/s	0,08	0,13	0,15	0,16	0,18	0,20	0,08	0,14	0,18	0,19	0,23	0,24						
	l/h	280	450	530	560	660	710	290	520	650	680	810	880						
Water pressure drop	kPa	6,8	15,3	20,6	23,5	30,8	34,7	6,7	18,6	29,1	31,5	42,9	48,9						
Water volume	l	1,4						1,8											
Heating mode, two pipes⁽²⁾																			
Heating capacity	kW	1,90	3,25	3,90	4,22	5,03	5,43	1,70	3,32	4,26	4,44	5,35	5,79	NA					
Water flow rate	l/s	0,09	0,16	0,19	0,20	0,24	0,26	0,08	0,16	0,21	0,21	0,26	0,28						
	l/h	330	570	680	730	870	940	300	580	740	770	930	1010						
Water pressure drop	kPa	8,3	19,6	26,5	30,3	40,7	46,5	7,6	22,6	34,2	36,7	50,4	57,9						
Water volume	l	1,4						1,8											
Cooling mode, four pipes⁽¹⁾																			
Total cooling capacity	kW	NA						1,59	2,60	3,19	3,31	3,88	4,15	1,64	2,79	3,49	3,63	4,33	4,69
Sensible cooling capacity	kW							1,29	2,12	2,62	2,72	3,21	3,46	1,33	2,25	2,83	2,94	3,53	3,84
Water flow	l/s							0,08	0,13	0,15	0,16	0,19	0,20	0,08	0,13	0,17	0,18	0,21	0,23
	l/h							270	450	550	570	670	720	280	480	605	630	750	810
Water pressure drop	kPa							6,7	16,2	24	25,7	33,8	38,2	6,3	16,1	24,65	26,6	36,7	42,5
Water volume	l							1,1						1,4					
Heating mode, four pipes⁽³⁾																			
Heating capacity	kW	NA						1,80	2,84	3,43	3,54	4,10	4,38	1,76	3,23	4,04	4,20	4,95	5,31
Water flow	l/s							0,04	0,07	0,08	0,09	0,10	0,11	0,04	0,08	0,10	0,10	0,12	0,13
	l/h							160	250	300	310	360	380	150	280	355	370	430	470
Water pressure drop	kPa							3	5,5	7,2	7,6	9,5	10,5	2,7	6,2	8,65	9,2	11,9	13,3
Water volume	l													0,5					
Electric heater																			
		230V ±10% - 1ph - 50Hz						230V ±10% - 1ph - 50Hz						230V ±10% - 1ph - 50Hz					
Maximum capacity	W	2000						2000						2000					
Current input	A	9,1						9,1						9,1					
Sound levels																			
Sound power level (global)	dB(A)	32	43	47	51	55	58	32	43	49	51	55	58	32	43	49	51	55	58
Electrical data, motor																			
Power input	W	4	11	18	24	43	58	4	11	21	24	43	58	4	11	21	24	43	58
Current input	A	0,04	0,09	0,13	0,17	0,28	0,39	0,04	0,09	0,15	0,17	0,28	0,39	0,04	0,09	0,15	0,17	0,28	0,39
FCEER [energy class] - 2 pipes		233 [A]						241 [A]											
FCCOP [energy class]		296 [A]						268 [A]											
FCEER [energy class] - 4 pipes								213 [A]						227 [A]					
FCCOP [energy class]								248 [B]						265 [A]					

Fan speed: L = Low, M = Medium, H = High



Eurovent certified values

- (1) Eurovent conditions: inlet air temperature = 27 °C db/47 % RH – water inlet temperature = 7 °C, water temperature difference = 5 K.
 (2) Eurovent conditions: inlet air temperature = 20 °C, water inlet temperature = 50 °C, water flow identical to cooling mode.
 (3) Eurovent conditions: inlet air temperature = 20 °C, water inlet temperature = 70 °C, water temperature difference = 10K.

7 - 42NH AND 42NL PERFORMANCE DATA

7.4 - Physical and electrical data at Eurovent conditions - 42NH - Sizes 2 and 3

With G3 filter - without plenum

42NH	225					235					229				
	R5	R4	R3	R2	R1	R5	R4	R3	R2	R1	2V	7V	8V	10V	
Fan speed															
(Eurovent certification speeds)	(L)			(M)	(H)	(L)			(M)	(H)	(L)	(M)	(H)		
Air flow	l/s	23	47	58	63	76	23	47	58	63	76	25	64	70	81,11
	m ³ /h	81	170	209	228	272	81	170	209	228	272	91	229	253	292
Available static pressure	Pa	6	28	42	50	71	6	28	42	50	71	8	50	61	81
Cooling mode, two pipes⁽¹⁾															
Total cooling capacity	kW	0,48	0,96	1,14	1,22	1,42	0,54	1,10	1,32	1,42	1,66	0,55	1,26	1,36	1,52
Sensible cooling capacity	kW	0,37	0,76	0,90	0,97	1,14	0,40	0,84	1,00	1,08	1,28	0,43	1,00	1,09	1,23
Water flow	l/s	0,02	0,05	0,06	0,06	0,07	0,03	0,05	0,06	0,07	0,08	0,03	0,06	0,07	0,075
	l/h	80	170	200	220	250	90	190	230	250	290	90	220	240	270
Water pressure drop	kPa	3,6	11,2	15,6	17,9	23,3	3,4	8,5	11,9	13,7	18,2	4,3	18	21,1	25,5
Water volume	l	0,4					0,5					0,4			
Heating mode, two pipes⁽²⁾															
Heating capacity	kW	0,57	1,14	1,37	1,47	1,71	0,62	1,27	1,54	1,67	1,96	0,64	1,48	1,61	1,81
Water flow	l/s	0,03	0,06	0,07	0,07	0,08	0,03	0,06	0,08	0,08	0,09	0,03	0,07	0,08	0,086
	l/h	100	200	240	260	300	110	220	270	290	340	110	260	280	310
Water pressure drop	kPa	4,5	12,9	17,4	19,6	25,2	3,3	10	13,5	15,4	20	5,4	19,8	22,8	27,9
Water volume	l	0,4					0,5					0,4			
Cooling mode, four pipes⁽¹⁾															
Total cooling capacity	kW	NA					0,44	0,84	0,99	1,07	1,24	NA			
Sensible cooling capacity	kW						0,36	0,71	0,84	0,90	1,06				
Water flow	l/s						0,02	0,04	0,05	0,05	0,06				
	l/h						80	150	180	190	220				
Water pressure drop	kPa						2,3	4	5,20	5,9	7,6				
Water volume	l	0,3													
Heating mode, four pipes⁽³⁾															
Heating capacity	kW	NA					0,68	1,35	1,61	1,72	1,98	NA			
Water flow	l/s						0,02	0,03	0,04	0,04	0,05				
	l/h						60	120	140	150	170				
Water pressure drop	kPa						1,8	3,8	4,7	5,2	6,4				
Water volume	l						0,2								
Electric heater															
Maximum capacity	W	230V ±10%					230V ±10%					230V ±10%			
Current input	A	1000					1000					1000			
		4,6					4,6					4,6			
Sound levels															
Sound power level (return and radiated)	dB(A)	32	43	48	49	53	32	43	48	49	53	36	50	52	56
Sound power level (supply)	dB(A)	31	40	46	49	52	31	40	46	49	52	37	51	53	58
Electrical data, motor															
Power input	W	13	20	41	43	44	13	20	41	43	44	3	18	22	33
Current input	A	0,13	0,16	0,22	0,23	0,24	0,13	0,16	0,22	0,23	0,24	0,05	0,22	0,28	0,39
FCEER [energy class] - 2 pipes		37 [D]					43 [C]					95 [A]			
FCCOP [energy class]		46 [C]					51 [C]					117 [A]			
FCEER [energy class] - 4 pipes							33 [D]								
FCCOP [energy class]							54 [C]								

Fan speed: L = Low, M = Medium, H = High



Eurovent certified values

- (1) Eurovent conditions: inlet air temperature = 27 °C db/47 % RH – water inlet temperature = 7 °C, water temperature difference = 5 K.
 (2) Eurovent conditions: inlet air temperature = 20 °C, water inlet temperature = 50 °C, water flow identical to cooling mode.
 (3) Eurovent conditions: inlet air temperature = 20 °C, water inlet temperature = 70 °C, water temperature difference = 10K.

7 - 42NH AND 42NL PERFORMANCE DATA

42NH	239				279				289				
	2V	7V	8V	10V	2V	6V	7V	10V	2V	6V	7V	10V	
Fan speed													
(Eurovent certification speeds)	(L)	(M)	(H)		(L)	(M)	(H)		(L)	(M)	(H)		
Air flow	l/s	25	64	70	81	32	85	97	124	36	96	108	134
	m ³ /h	91	229	253	292	116	305	349	446	128	347	387	481
Available static pressure	Pa	8	50	61	81	7	50	65	107	7	50	62	96
Cooling mode, two pipes⁽¹⁾													
Total cooling capacity	kW	0,62	1,45	1,58	1,78	0,78	1,86	2,07	2,45	1,00	2,44	2,67	3,15
Sensible cooling capacity	kW	0,46	1,11	1,22	1,38	0,59	1,44	1,61	1,94	0,71	1,79	1,97	2,35
Water flow	l/s	0,03	0,07	0,08	0,09	0,04	0,09	0,10	0,12	0,05	0,12	0,13	0,16
	l/h	110	250	280	310	130	320	360	430	170	420	470	560
Water pressure drop	kPa	3,7	13,8	16,2	20,4	4,7	21,9	26,9	36,1	4,4	21	25,1	33,5
Water volume	l	0,5				0,5				0,6			
Heating mode, two pipes⁽²⁾													
Heating capacity	kW	0,70	1,68	1,84	2,09	0,88	2,17	2,44	2,98	1,05	2,78	3,09	3,79
Water flow	l/s	0,03	0,08	0,09	0,10	0,04	0,11	0,12	0,14	0,05	0,13	0,15	0,18
	l/h	120	290	320	360	150	380	420	520	180	480	540	660
Water pressure drop	kPa	3,9	15,5	18	22,2	5,7	23,7	28,9	40,7	4,9	23,3	27,8	39,5
Water volume	l	0,5				0,5				0,6			
Cooling mode, four pipes⁽¹⁾													
Total cooling capacity	kW	0,49	1,10	1,19	1,33	0,60	1,39	1,53	1,79	0,94	2,17	2,35	2,72
Sensible cooling capacity	kW	0,41	0,93	1,01	1,14	0,50	1,19	1,32	1,57	0,68	1,66	1,81	2,13
Water flow	l/s	0,02	0,05	0,06	0,06	0,03	0,07	0,08	0,09	0,04	0,11	0,11	0,13
	l/h	80	190	210	230	100	240	270	320	160	380	410	480
Water pressure drop	kPa	2,4	6	6,8	8,4	2,8	8,9	10,7	14,5	5,9	26	30	39
Water volume	l	0,3				0,3				0,4			
Heating mode, four pipes⁽³⁾													
Heating capacity	kW	0,77	1,73	1,88	2,09	0,96	2,16	2,37	2,75	0,97	2,29	2,53	3,09
Water flow	l/s	0,02	0,04	0,04	0,05	0,02	0,05	0,06	0,07	0,03	0,06	0,06	0,08
	l/h	70	150	160	180	80	190	210	240	90	200	220	270
Water pressure drop	kPa	2	5,3	5,9	6,9	2,5	7,3	8,4	10,6	2,5	7,8	9,1	12,5
Water volume	l	0,2				0,2				0,3			
Electric heater													
Maximum capacity	W	230V ±10%				230V ±10%				230V ±10%			
Current input	A	1000				1000				1000			
		4,6				4,6				4,6			
Sound levels													
Sound power level (return and radiated)	dB(A)	36	50	52	56	34	52	54	61	36	54	57	61
Sound power level (supply)	dB(A)	37	51	53	58	34	55	58	64	35	56	59	65
Electrical data, motor													
Power input	W	3	18	22	33	4	25	36	70	7	36	49	50
Current input	A	0,05	0,22	0,28	0,39	0,06	0,29	0,40	0,75	0,08	0,31	0,40	0,91
FCEER [energy class] - 2 pipes		109 [A]				98 [A]				85 [A]			
FCCOP [energy class]		130 [A]				118 [A]				97 [A]			
FCEER [energy class] - 4 pipes		84 [B]				74 [B]				78 [B]			
FCCOP [energy class]		138 [A]				123 [A]				84 [B]			

Fan speed: L = Low, M = Medium, H = High



Eurovent certified values

- (1) Eurovent conditions: inlet air temperature = 27 °C db/47 % RH – water inlet temperature = 7 °C, water temperature difference = 5 K.
 (2) Eurovent conditions: inlet air temperature = 20 °C, water inlet temperature = 50 °C, water flow identical to cooling mode.
 (3) Eurovent conditions: inlet air temperature = 20 °C, water inlet temperature = 70 °C, water temperature difference = 10K.

7 - 42NH AND 42NL PERFORMANCE DATA

42NH	325					335					
Fan speed	R5	R4	R3	R2	R1	R5	R4	R3	R2	R1	
(Eurovent certification speeds)		(L)	(M)	(H)	Max		(L)	(M)	(H)	Max	
Air flow	l/s	55	79	102	131	160	55	79	102	131	160
	m ³ /h	197	284	366	471	577	197	284	366	471	577
Available static pressure	Pa	14	30	50	83	124	14	30	50	83	124
Cooling mode, two pipes⁽¹⁾											
Total cooling capacity	kW	0,94	1,27	1,55	1,87	2,16	1,10	1,57	1,98	2,48	2,95
Sensible cooling capacity	kW	0,76	1,06	1,31	1,61	1,89	0,84	1,22	1,55	1,96	2,36
Water flow	l/s	0,05	0,07	0,08	0,10	0,11	0,06	0,08	0,10	0,13	0,15
	l/h	180	240	290	350	400	210	290	370	460	540
Water pressure drop	kPa	5,9	9,6	13,6	19,1	24,2	5	9	15	23	31
Water volume	l	0,7					0,9				
Heating mode, two pipes⁽²⁾											
Heating capacity	kW	1,36	1,87	2,30	2,77	3,18	0,57	2,11	2,66	3,30	3,88
Water flow	l/s	0,07	0,09	0,11	0,13	0,15	0,07	0,10	0,13	0,16	0,19
	l/h	240	320	400	480	550	260	370	460	570	680
Water pressure drop	kPa	10,9	16,7	22,7	30,3	37,7	8,2	13,9	20,3	29,2	38,5
Water volume	l	0,7					0,9				
Cooling mode, four pipes⁽¹⁾											
Total cooling capacity	kW	NA					1,15	1,58	1,94	2,34	2,70
Sensible cooling capacity	kW						0,86	1,21	1,51	1,86	2,18
Water flow	l/s						0,06	0,08	0,10	0,12	0,14
	l/h						220	290	360	430	500
Water pressure drop	kPa						8,5	14,5	21,0	28,6	36,3
Water volume	l	0,6									
Heating mode, four pipes⁽³⁾											
Heating capacity	kW	NA					1,71	2,32	2,81	3,31	3,69
Water flow	l/s						0,04	0,06	0,07	0,08	0,09
	l/h						150	200	250	290	320
Water pressure drop	kPa						6,4	10,2	13,8	18	21,6
Water volume	l						0,3				
Electric heater											
		230V ±10% - 1ph - 50Hz					230V ±10% - 1ph - 50Hz				
Maximum capacity	W	1600					1600				
Current input	A	7,3					7,3				
Sound levels											
Sound power level (return and radiated)	dB(A)	42	45	49	56	60	42	45	49	56	60
Sound power level (supply)	dB(A)	46	48	54	61	66	46	48	54	61	66
Electrical data, motor											
Power input	W	109	126	146	168	190	109	126	146	168	190
Current input	A	0,50	0,57	0,65	0,75	0,88	0,50	0,57	0,65	0,75	0,88
FCEER [energy class] - 2 pipes		10 [E]					13 [E]				
FCCOP [energy class]		15 [E]					17 [E]				
FCEER [energy class] - 4 pipes							13 [E]				
FCCOP [energy class]							19 [E]				

Fan speed: L = Low, M = Medium, H = High



Eurovent certified values

(1) Eurovent conditions: inlet air temperature = 27 °C db/47 % RH – water inlet temperature = 7 °C, water temperature difference = 5 K.

(2) Eurovent conditions: inlet air temperature = 20 °C, water inlet temperature = 50 °C, water flow identical to cooling mode.

(3) Eurovent conditions: inlet air temperature = 20 °C, water inlet temperature = 70 °C, water temperature difference = 10K.

7 - 42NH AND 42NL PERFORMANCE DATA

42NH		329				339			
Fan speed		2V	3.7V	4.5V	10V	2V	3.7V	4.5V	10V
(Eurovent certification speeds)		(L)	(M)	(H)	Max	(L)	(M)	(H)	Max
Air flow	l/s	59	125	147	212	59	124	146	212
	m ³ /h	213	450	528	764	212	447	527	763
Available static pressure	Pa	11	50,1	69	143	11	50	70	145
Cooling mode, two pipes⁽¹⁾									
Total cooling capacity	kW	1,11	1,93	2,15	2,64	1,29	2,50	2,85	3,70
Sensible cooling capacity	kW	0,92	1,68	1,89	2,38	1,01	2,00	2,29	3,04
Water flow	l/s	0,05	0,10	0,11	0,13	0,06	0,12	0,14	0,19
	l/h	190	342	380	480	220	433	500	670
Water pressure drop	kPa	6,5	18	22	32,7	6,6	22	28	45,3
Water volume	l	0,7				0,9			
Heating mode, two pipes⁽²⁾									
Heating capacity	kW	1,46	2,68	3,01	3,74	1,61	3,16	3,61	4,70
Water flow	l/s	0,07	0,13	0,14	0,18	0,08	0,15	0,17	0,23
	l/h	250	466	520	650	280	547	625	820
Water pressure drop	kPa	11,9	28,7	34,3	49,2	9,0	27,2	34,1	53,5
Water volume	l	0,7				0,9			
Cooling mode, four pipes⁽¹⁾									
Total cooling capacity	kW	NA				1,22	2,38	2,65	3,30
Sensible cooling capacity	kW					1,03	1,90	2,15	2,75
Water flow	l/s					0,06	0,11	0,13	0,17
	l/h					230	410	470	600
Water pressure drop	kPa					9,5	26,8	32,6	49,6
Water volume	l					0,6			
Heating mode, four pipes⁽³⁾									
Heating capacity	kW	NA				1,82	3,20	3,51	4,34
Water flow	l/s					0,04	0,08	0,08	0,11
	l/h					160	278	305	380
Water pressure drop	kPa					7,0	17,14	19,9	28,6
Water volume	l								
Electric heater		230V ±10% - 1ph - 50Hz				230V ±10% - 1ph - 50Hz			
Maximum capacity	W	1600				1600			
Current input	A	7,3				7,3			
Sound levels									
Sound power level (return and radiated)	dB(A)	37	54	58	67	37	54	58	67
Sound power level (supply)	dB(A)	40	59	63	71	40	59	63	71
Electrical data, motor									
Power input	W	8	37	58,5	174	8	37	58,5	172
Current input	A	0,11	0,57	0,79	1,35	0,11	0,57	0,79	1,35
FCEER [energy class] - 2 pipes		73 [B]				90 [A]			
FCCOP [energy class]		104 [A]				118 [A]			
FCEER [energy class] - 4 pipes						85 [A]			
FCCOP [energy class]						127 [A]			

Fan speed: L = Low, M = Medium, H = High



Eurovent certified values

- (1) Eurovent conditions: inlet air temperature = 27 °C db/47 % RH – water inlet temperature = 7 °C, water temperature difference = 5 K.
 (2) Eurovent conditions: inlet air temperature = 20 °C, water inlet temperature = 50 °C, water flow identical to cooling mode.
 (3) Eurovent conditions: inlet air temperature = 20 °C, water inlet temperature = 70 °C, water temperature difference = 10K.

7 - 42NH AND 42NL PERFORMANCE DATA

7.5 - Physical and electrical data at Eurovent conditions - 42NH - Size 4

With G3 filter - without plenum

42NH	425					435					
Fan speed	R5	R4	R3	R2	R1	R5	R4	R3	R2	R1	
(Eurovent certification speeds)	(L)	(M)	(H)		Max	(L)	(M)	(H)		Max	
Air flow	l/s	89	140	166	189	197	89	140	166	189	197
	m ³ /h	320	505	599	679	709	320	505	599	679	709
Available static pressure	Pa	20	50	70	90	98	20	50	70	90	98
Cooling mode, two pipes⁽¹⁾											
Total cooling capacity	kW	1,72	2,60	3,01	3,30	3,40	1,84	3,07	3,62	4,02	4,14
Sensible cooling capacity	kW	1,37	2,10	2,44	2,71	2,80	1,44	2,36	2,79	3,12	3,22
Water flow	l/s	0,09	0,13	0,15	0,16	0,17	0,09	0,15	0,18	0,20	0,20
	l/h	310	460	530	580	600	330	540	640	710	730
Water pressure drop	kPa	8,7	18	22,6	26,5	28	10	25,1	33,9	40	42,1
Water volume	l	1,0					1,3				
Heating mode, two pipes⁽²⁾											
Heating capacity	kW	1,98	3,16	3,75	4,22	4,39	2,02	3,32	3,99	4,53	4,72
Water flow	l/s	0,09	0,15	0,18	0,20	0,21	0,10	0,16	0,19	0,22	0,23
	l/h	340	550	650	730	760	350	580	690	790	820
Water pressure drop	kPa	9,3	19,8	26,3	32,2	34,5	10,6	23,8	32,4	40,2	43,2
Water volume	l	1,0					1,3				
Cooling mode, four pipes⁽¹⁾											
Total cooling capacity	kW	NA					1,76	2,66	3,06	3,36	3,45
Sensible cooling capacity	kW	NA					1,39	2,14	2,49	2,75	2,84
Water flow	l/s	NA					0,09	0,13	0,15	0,16	0,17
	l/h	NA					320	470	540	590	610
Water pressure drop	kPa	NA					11,3	23,5	29,8	34,7	36,5
Water volume	l	NA					0,9				
Heating mode, four pipes⁽³⁾											
Heating capacity	kW	NA					2,13	3,51	4,14	4,64	4,81
Water flow	l/s	NA					0,05	0,09	0,10	0,11	0,12
	l/h	NA					190	310	360	410	420
Water pressure drop	kPa	NA					10	22,4	29,7	36	38,3
Water volume	l	NA					0,5				
Electric heater											
		230V ±10% - 1ph - 50Hz					230V ±10% - 1ph - 50Hz				
Maximum capacity	W	2000					2000				
Current input	A	9,1					9,1				
Sound levels											
Sound power level (return and radiated)	dB(A)	43	51	55	57	58	43	51	55	57	58
Sound power level (supply)	dB(A)	47	54	58	60	61	47	54	58	60	61
Electrical data, motor											
Power input	W	79	87	94	103	117	79	87	94	103	117
Current input	A	0,43	0,51	0,62	0,67	0,72	0,43	0,51	0,62	0,67	0,72
FCEER [energy class] - 2 pipes		25 [E]					28 [D]				
FCCOP [energy class]		29 [D]					30 [D]				
FCEER [energy class] - 4 pipes							26 [D]				
FCCOP [energy class]							32 [D]				

Fan speed: L = Low, M = Medium, H = High



Eurovent certified values

- (1) Eurovent conditions: inlet air temperature = 27 °C db/47 % RH – water inlet temperature = 7 °C, water temperature difference = 5 K.
 (2) Eurovent conditions: inlet air temperature = 20 °C, water inlet temperature = 50 °C, water flow identical to cooling mode.
 (3) Eurovent conditions: inlet air temperature = 20 °C, water inlet temperature = 70 °C, water temperature difference = 10K.

7 - 42NH AND 42NL PERFORMANCE DATA

42NH		429					439				
Fan speed		2V	3.7V	5V	7V	9V	2V	3.7V	5V	7V	9V
(Eurovent certification speeds)		(L)	(M)	(H)		Max	(L)	(M)	(H)		Max
Air flow	l/s	61	129	159	212	219	61	129	159	212	219
	m ³ /h	218	464,2	574	764	787	218	464,2	574	764	787
Available static pressure	Pa	11	50,4	76	135	143	11	50,4	76	135	143
Cooling mode, two pipes⁽¹⁾											
Total cooling capacity	kW	1,26	2,46	2,90	3,56	3,61	1,22	2,85	3,50	4,31	4,35
Sensible cooling capacity	kW	1,00	1,99	2,37	2,95	2,99	0,99	2,21	2,70	3,38	3,42
Water flow	l/s	0,06	0,12	0,14	0,18	0,18	0,06	0,14	0,17	0,21	0,22
	l/h	220	426	510	640	650	210	494	610	770	780
Water pressure drop	kPa	4,8	15,82	21,3	30,7	31,7	4,8	21,51	31,9	45,6	46,7
Water volume	l	1,0					1,3				
Heating mode, two pipes⁽²⁾											
Heating capacity	kW	1,34	2,91	3,59	4,69	4,80	1,38	3,03	3,81	5,05	5,17
Water flow	l/s	0,06	0,14	0,17	0,23	0,23	0,07	0,15	0,18	0,24	0,25
	l/h	230	504	620	820	830	240	528	660	880	900
Water pressure drop	kPa	5,2	17,31	24,5	38,5	40,1	5,8	20,57	29,9	48,4	50,5
Water volume	l	1,0					1,3				
Cooling mode, four pipes⁽¹⁾											
Total cooling capacity	kW	NA					1,28	2,52	2,97	3,59	3,63
Sensible cooling capacity	kW						1,02	2,03	2,41	2,97	3,01
Water flow	l/s						0,06	0,12	0,14	0,18	0,18
	l/h						220	436	520	640	650
Water pressure drop	kPa						6,1	20,71	28,4	39,6	40,7
Water volume	l						0,9				
Heating mode, four pipes⁽³⁾											
Heating capacity	kW	NA					1,34	3,21	3,97	5,10	5,21
Water flow	l/s						0,03	0,08	0,10	0,13	0,13
	l/h						120	279	350	450	460
Water pressure drop	kPa						5	19,45	27,7	42,5	44,1
Water volume	l						0,5				
Electric heater							230V ±10% - 1ph - 50Hz				
Maximum capacity	W	1600					1600				
Current input	A	7,3					7,3				
Sound levels											
Sound power level (return and radiated)	dB(A)	37	54	60	66	66	37	54	60	66	66
Sound power level (supply)	dB(A)	40	62	67	72	72	40	62	67	72	72
Electrical data, motor											
Power input	W	8	36,3	74	147	174	8	36,3	74	147	174
Current input	A	0,12	0,43	0,98	1,26	1,31	0,12	0,43	0,98	1,26	1,31
FCEER [energy class] - 2 pipes		86 [A]					92 [A]				
FCCOP [energy class]		100 [A]					104 [A]				
FCEER [energy class] - 4 pipes							88 [A]				
FCCOP [energy class]							106 [A]				

Fan speed: L = Low, M = Medium, H = High



Eurovent certified values

- (1) Eurovent conditions: inlet air temperature = 27 °C db/47 % RH – water inlet temperature = 7 °C, water temperature difference = 5 K.
 (2) Eurovent conditions: inlet air temperature = 20 °C, water inlet temperature = 50 °C, water flow identical to cooling mode.
 (3) Eurovent conditions: inlet air temperature = 20 °C, water inlet temperature = 70 °C, water temperature difference = 10K.

7 - 42NH AND 42NL PERFORMANCE DATA

7.6 - Physical and electrical data at Eurovent conditions - 42NH - Size 5

With G3 filter - without plenum

42NH	525					535					545					
Fan speed	R5	R4	R3	R2	R1	R5	R4	R3	R2	R1	R5	R4	R3	R2	R1	
(Eurovent certification speeds)	(L)	(M)	(H)		Max	(L)	(M)	(H)		Max	(L)	(M)	(H)		Max	
Air flow	l/s	213	240	257	268	279	213	240	257	268	279	213	240	257	268	279
	m ³ /h	767	863	924	964	1004	767	863	924	964	1004	767	863	925	964	1004
Available static pressure	Pa	40	50	57	62	68	40	50	57	62	68	40	50	57	62	68
Cooling mode, two pipes⁽¹⁾																
Total cooling capacity	kW	3,52	3,84	4,03	4,15	4,25	4,33	4,77	5,05	5,21	5,36	NA				
Sensible cooling capacity	kW	2,94	3,23	3,41	3,51	3,62	3,41	3,79	4,02	4,16	4,29					
Water flow	l/s	0,17	0,19	0,20	0,20	0,21	0,21	0,23	0,25	0,26	0,26					
	l/h	620	680	710	730	750	760	840	890	920	940					
Water pressure drop	kPa	28,5	32,3	35	36,8	38,5	38,2	45,3	49,6	52,3	55					
Water volume	l	1,4					1,8									
Heating mode, two pipes⁽²⁾																
Heating capacity	kW	4,72	5,19	5,47	5,64	5,81	5,00	5,53	5,84	6,03	6,20	NA				
Water flow rate	l/s	0,23	0,25	0,26	0,27	0,28	0,24	0,27	0,28	0,29	0,30					
	l/h	820	900	950	980	1010	870	960	1020	1050	1080					
Water pressure drop	kPa	36,5	43	47,1	49,7	52,2	45	53,4	58,7	62	65,1					
Water volume	l	1,4					1,8									
Cooling mode, four pipes⁽¹⁾																
Total cooling capacity	kW	NA					3,59	3,93	4,13	4,25	4,36	3,99	4,40	4,66	4,82	4,97
Sensible cooling capacity	kW						2,96	3,25	3,43	3,55	3,65	3,23	3,58	3,81	3,95	4,08
Water flow	l/s						0,18	0,19	0,20	0,21	0,21	0,19	0,22	0,23	0,24	0,24
	l/h						640	690	730	750	770	700	780	820	850	880
Water pressure drop	kPa						30,6	35,5	38,7	40,5	42,5	32,8	38,9	43	45,6	47,9
Water volume	l						1,1					1,4				
Heating mode, four pipes⁽³⁾																
Heating capacity	kW	NA					3,89	4,21	4,41	4,52	4,64	4,67	5,10	5,34	5,48	5,61
Water flow	l/s						0,09	0,10	0,11	0,11	0,11	0,11	0,13	0,13	0,13	0,14
	l/h						340	370	390	400	410	410	450	470	480	490
Water pressure drop	kPa						8,7	9,9	10,6	11,1	11,5	10,8	12,4	13,4	14	14,5
Water volume	l						0,5					0,6				
Electric heater																
		230V ±10% - 1ph - 50Hz					230V ±10% - 1ph - 50Hz					230V ±10% - 1ph - 50Hz				
Maximum capacity	W	2000					2000					2000				
Current input	A	9,1					9,1					9,1				
Sound levels																
Sound power level (return and radiated)	dB(A)	55	56	57	58	58	55	56	57	58	58	55	56	57	58	58
Sound power level (supply)	dB(A)	55	57	59	60	61	55	57	59	60	61	55	57	59	60	61
Electrical data, motor																
Power input	W	105	113	117	124	134	105	113	117	124	134	105	113	117	124	134
Current input	A	0,59	0,64	0,67	0,71	0,76	0,59	0,64	0,67	0,71	0,76	0,59	0,64	0,67	0,71	0,76
FCEER [energy class] - 2 pipes		34 [D]					42 [C]									
FCCOP [energy class]		45 [C]					48 [C]									
FCEER [energy class] - 4 pipes							34 [D]					38 [D]				
FCCOP [energy class]							37 [D]					45 [C]				

Fan speed: L = Low, M = Medium, H = High



Eurovent certified values

- (1) Eurovent conditions: inlet air temperature = 27 °C db/47 % RH – water inlet temperature = 7 °C, water temperature difference = 5 K.
- (2) Eurovent conditions: inlet air temperature = 20 °C, water inlet temperature = 50 °C, water flow identical to cooling mode.
- (3) Eurovent conditions: inlet air temperature = 20 °C, water inlet temperature = 70 °C, water temperature difference = 10K.

7 - 42NH AND 42NL PERFORMANCE DATA

42NH	529					539					549					
Fan speed	2V	5V	6V	8V	10V	2V	5V	6V	8V	10V	2V	5V	6V	8V	10V	
(Eurovent certification speeds)	(L)	(M)	(H)		Max	(L)	(M)	(H)		Max	(L)	(M)	(H)		Max	
Air flow	l/s	85	213	244	307	347	85	213	244	307	347	85	213	244	307	347
	m ³ /h	306	765	878	1105	1249	306	765	878	1105	1249	306	765	878	1105	1249
Available static pressure	Pa	8	50	66	104	133	8	50	66	104	133	8	50	66	104	133
Cooling mode, two pipes⁽¹⁾																
Total cooling capacity	kW	1,70	3,57	3,93	4,54	4,86	1,77	4,37	4,88	5,72	6,13	NA				
Sensible cooling capacity	kW	1,37	2,98	3,31	3,89	4,19	1,41	3,46	3,88	4,63	5,01					
Water flow	l/s	0,08	0,17	0,19	0,22	0,24	0,08	0,21	0,24	0,28	0,30					
	l/h	290	620	690	800	870	300	760	850	1010	1090					
Water pressure drop	kPa	7,2	28,4	33	42,9	49,1	7,2	38,1	46,5	61,6	70,3					
Water volume	l	1,4					1,8									
Heating mode, two pipes⁽²⁾																
Heating capacity	kW	1,98	4,71	5,26	6,20	6,68	1,80	4,99	5,61	6,61	7,07	NA				
Water flow	l/s	0,09	0,23	0,26	0,30	0,32	0,09	0,24	0,27	0,32	0,34					
	l/h	340	820	920	1080	1160	310	870	980	1150	1230					
Water pressure drop	kPa	8,8	36,4	44	58,3	66,4	8,4	44,8	54,8	72,6	81,6					
Water volume	l	1,4					1,8									
Cooling mode, four pipes⁽¹⁾																
Total cooling capacity	kW	NA					1,65	3,64	4,01	4,64	4,97	1,73	4,03	4,51	5,35	6,02
Sensible cooling capacity	kW						1,34	3,00	3,33	3,92	4,23	1,39	3,28	3,68	4,42	5,04
Water flow	l/s						0,08	0,18	0,19	0,23	0,25	0,08	0,19	0,22	0,26	0,29
	l/h						280	630	700	820	890	300	700	790	940	1030
Water pressure drop	kPa						7,2	30,5	36,3	47,3	54	6,8	32,8	40	54,3	62
Water volume	l						1,1					1,4				
Heating mode, four pipes⁽³⁾																
Heating capacity	kW	NA					1,87	3,88	4,26	4,90	5,23	1,88	4,66	5,16	5,91	7,44
Water flow	l/s						0,04	0,09	0,10	0,12	0,13	0,04	0,11	0,13	0,14	0,18
	l/h						160	340	370	430	460	160	410	450	520	650
Water pressure drop	kPa						3,2	8,7	10,1	12,6	14	2,9	10,8	12,7	15,8	22
Water volume	l											0,5				
Electric heater																
		230V ±10% - 1ph - 50Hz					230V ±10% - 1ph - 50Hz					230V ±10% - 1ph - 50Hz				
Maximum capacity	W	2000					2000					2000				
Current input	A	9,1					9,1					9,1				
Sound levels																
Sound power level (return and radiated)	dB(A)	35	53	57	63	66	35	53	57	63	66	35	53	57	63	66
Sound power level (supply)	dB(A)	36	57	61	66	70	36	57	61	66	70	36	57	61	66	70
Electrical data, motor																
Power input	W	9	52	78	146	212	9	52	78	146	212	9	52	78	146	212
Current input	A	0,12	0,67	0,95	1,58	1,88	0,12	0,67	0,95	1,58	1,88	0,12	0,67	0,95	1,58	1,88
FCEER [energy class] - 2 pipes		94 [A]					107 [A]									
FCCOP [energy class]		122 [A]					120 [A]									
FCEER [energy class] - 4 pipes							93 [A]					101 [A]				
FCCOP [energy class]							107 [A]					118 [A]				

Fan speed: L = Low, M = Medium, H = High



Eurovent certified values

- (1) Eurovent conditions: inlet air temperature = 27 °C db/47 % RH – water inlet temperature = 7 °C, water temperature difference = 5 K.
(2) Eurovent conditions: inlet air temperature = 20 °C, water inlet temperature = 50 °C, water flow identical to cooling mode.
(3) Eurovent conditions: inlet air temperature = 20 °C, water inlet temperature = 70 °C, water temperature difference = 10K.

7 - 42NH AND 42NL PERFORMANCE DATA

7.7 - Physical and electrical data at Eurovent conditions - 42NH - Sizes 6 and 7

With G3 filter - without plenum

42NH	635					645					
Fan speed	R5	R4	R3	R2	R1	R5	R4	R3	R2	R1	
(Eurovent certification speeds)		(L)	(M)	(H)	Max		(L)	(M)	(H)	Max	
Air flow	l/s	200	298	397	460	499	200	298	397	460	499
	m ³ /h	720	1072	1428	1657	1796	720	1072	1428	1657	1796
Available static pressure	Pa	13	28	50	67	79	13	28	50	67	79
Cooling mode, two pipes⁽¹⁾											
Total cooling capacity	kW	4,03	5,81	7,31	8,08	8,47	4,57	6,80	8,62	9,52	9,97
Sensible cooling capacity	kW	3,17	4,62	5,94	6,67	7,06	3,44	5,14	6,65	7,49	7,92
Water flow	l/s	0,20	0,29	0,36	0,40	0,42	0,23	0,33	0,42	0,47	0,49
	l/h	720	1030	1290	1430	1500	820	1200	1520	1680	1760
Water pressure drop	kPa	12,3	24	35	41,3	45,1	12,1	25	38,6	45,1	49
Water volume	l	1,5					2				
Heating mode, two pipes⁽²⁾											
Heating capacity	kW	5,21	7,59	9,76	11,00	11,67	5,56	8,21	10,59	11,92	12,64
Water flow	l/s	0,25	0,37	0,47	0,53	0,56	0,27	0,40	0,51	0,58	0,61
	l/h	910	1320	1700	1910	2030	970	1430	1840	2070	2200
Water pressure drop	kPa	15,9	29,7	45,6	56	62,1	14,8	28,1	43,4	53,1	58,8
Water volume	l	1,5					2,0				
Cooling mode, four pipes⁽¹⁾											
Total cooling capacity	kW	NA					3,80	5,38	6,63	7,22	7,52
Sensible cooling capacity	kW	NA					3,05	4,40	5,56	6,18	6,50
Water flow	l/s	NA					0,19	0,27	0,33	0,36	0,37
	l/h	NA					680	960	1180	1280	1340
Water pressure drop	kPa	NA					11,1	20,9	29,9	34,4	37,1
Water volume	l	NA					1,3				
Heating mode, four pipes⁽³⁾											
Heating capacity	kW	NA					4,92	6,79	8,05	8,57	8,82
Water flow	l/s	NA					0,12	0,17	0,20	0,21	0,21
	l/h	NA					430	600	710	750	770
Water pressure drop	kPa	NA					6,6	10,8	14,2	15,7	16,5
Water volume	l	NA					0,7				
Electric heater											
Maximum capacity	W	230V ±10% - 1ph - 50Hz					230V ±10% - 1ph - 50Hz				
Current input	A	3200					3200				
		14,6					14,6				
Sound levels											
Sound power level (return and radiated)	dB(A)	50	56	58	61	62	50	56	58	61	62
Sound power level (supply)	dB(A)	50	59	62	65	66	50	59	62	65	66
Electrical data, motor											
Power input	W	185	217	225	242	286	185	217	225	242	286
Current input	A	0,96	1,11	1,28	1,38	1,55	0,96	1,11	1,28	1,38	1,55
FCEER [energy class] - 2 pipes		29 [D]					34 [D]				
FCCOP [energy class]		38 [D]					41 [C]				
FCEER [energy class] - 4 pipes							26 [D]				
FCCOP [energy class]							33 [D]				

Fan speed: L = Low, M = Medium, H = High



Eurovent certified values

- (1) Eurovent conditions: inlet air temperature = 27 °C db/47 % RH – water inlet temperature = 7 °C, water temperature difference = 5 K.
 (2) Eurovent conditions: inlet air temperature = 20 °C, water inlet temperature = 50 °C, water flow identical to cooling mode.
 (3) Eurovent conditions: inlet air temperature = 20 °C, water inlet temperature = 70 °C, water temperature difference = 10K.

7 - 42NH AND 42NL PERFORMANCE DATA

42NH		639				649			
Fan speed		2V	6V	7V	10V	2V	7V	8V	10V
(Eurovent certification speeds)		(L)	(M)	(H)	Max	(L)	(M)	(H)	Max
Air flow	l/s	102	269	303	389	90	327	364	426
	m ³ /h	368	967	1089	1400	323	1176	1310	1532
Available static pressure	Pa	7	50	63	105	4	50	62	85
Cooling mode, two pipes⁽¹⁾									
Total cooling capacity	kW	1,76	5,44	5,99	7,21	1,87	7,49	8,14	9,04
Sensible cooling capacity	kW	1,40	4,34	4,80	5,85	1,51	5,71	6,25	7,04
Water flow	l/s	0,08	0,26	0,29	0,36	0,09	0,36	0,39	0,44
	l/h	300	950	1050	1280	320	1300	1420	1590
Water pressure drop	kPa	3,5	20,3	24,6	34,2	3,7	29,1	34,4	41,3
Water volume	l	1,5				2			
Heating mode, two pipes⁽²⁾									
Heating capacity	kW	2,19	6,90	7,70	9,60	2,33	8,94	9,84	11,21
Water flow	l/s	0,11	0,33	0,37	0,46	0,11	0,43	0,48	0,54
	l/h	380	1200	1340	1670	410	1550	1710	1950
Water pressure drop	kPa	4,1	25,3	30,4	44,4	3,7	32,5	38,3	47,8
Water volume	l	1,5				2			
Cooling mode, four pipes⁽¹⁾									
Total cooling capacity	kW	NA				1,83	5,90	6,33	6,91
Sensible cooling capacity	kW					1,48	4,87	5,27	5,85
Water flow	l/s					0,09	0,29	0,31	0,34
	l/h					310	1030	1110	1230
Water pressure drop	kPa					3,6	23,9	27,7	32
Water volume	l	1,3							
Heating mode, four pipes⁽³⁾									
Heating capacity	kW	NA				2,17	7,22	7,70	8,30
Water flow	l/s					0,05	0,18	0,19	0,20
	l/h					190	630	670	730
Water pressure drop	kPa					2,3	11,9	13,2	14,9
Water volume	l					0,7			
Electric heater		230V ±10% - 1ph - 50Hz				230V ±10% - 1ph - 50Hz			
Maximum capacity	W	3200				3200			
Current input	A	14,6				14,6			
Sound levels									
Sound power level (return and radiated)	dB(A)	38	58	61	67	38	61	64	67
Sound power level (supply)	dB(A)	46	60	63	69	46	63	66	69
Electrical data, motor									
Power input	W	8	76	106	222	9	111	153	233
Current input	A	0,09	0,71	1,02	2,01	0,09	0,71	1,02	2,01
FCEER [energy class] - 2 pipes		92 [A]				83 [B]			
FCCOP [energy class]		122 [A]				105 [A]			
FCEER [energy class] - 4 pipes						70 [B]			
FCCOP [energy class]						89 [A]			

Fan speed: L = Low, M = Medium, H = High



Eurovent certified values

- (1) Eurovent conditions: inlet air temperature = 27 °C db/47 % RH – water inlet temperature = 7 °C, water temperature difference = 5 K.
 (2) Eurovent conditions: inlet air temperature = 20 °C, water inlet temperature = 50 °C, water flow identical to cooling mode.
 (3) Eurovent conditions: inlet air temperature = 20 °C, water inlet temperature = 70 °C, water temperature difference = 10K.

7 - 42NH AND 42NL PERFORMANCE DATA

42NH	735					745					
Fan speed	R5	R4	R3	R2	R1	R5	R4	R3	R2	R1	
(Eurovent certification speeds)			(L)	(M)	(H)			(L)	(M)	(H)	
Air flow	l/s	148	218	374	533	600	148	218	374	533	600
	m ³ /h	534	785	1346	1918	2161	534	785	1346	1918	2161
Available static pressure	Pa	4	8	25	50	63	4	8	25	50	63
Cooling mode, two pipes⁽¹⁾											
Total cooling capacity	kW	3,19	4,66	7,62	9,97	10,76	3,43	5,09	8,52	11,32	12,25
Sensible cooling capacity	kW	2,42	3,55	5,92	7,98	8,72	2,55	3,77	6,41	8,75	9,60
Water flow	l/s	0,16	0,23	0,38	0,49	0,53	0,17	0,25	0,42	0,56	0,60
	l/h	580	840	1360	1770	1910	620	910	1510	2000	2160
Water pressure drop	kPa	9,1	18,1	42,5	66,4	75,8	7,9	16	41,8	66,2	75,9
Water volume	l	2					2,6				
Heating mode, two pipes⁽²⁾											
Heating capacity	kW	3,81	5,46	9,03	12,49	13,86	3,85	5,62	9,55	13,38	14,88
Water flow	l/s	0,18	0,26	0,44	0,60	0,67	0,19	0,27	0,46	0,65	0,72
	l/h	660	950	1570	2170	2410	670	980	1660	2330	2590
Water pressure drop	kPa	10,7	19,1	44,7	78,2	93,7	9	16,3	39,5	70,5	84,8
Water volume	l	2					2,6				
Cooling mode, four pipes⁽¹⁾											
Total cooling capacity	kW	2,80	3,95	6,29	8,28	8,99	3,33	4,94	8,11	10,46	11,18
Sensible cooling capacity	kW	2,22	3,17	5,16	6,96	7,61	2,50	3,69	6,18	8,25	8,96
Water flow	l/s	0,14	0,20	0,31	0,41	0,44	0,17	0,25	0,40	0,51	0,55
	l/h	510	720	1130	1480	1600	600	890	1440	1850	1980
Water pressure drop	kPa	8,9	16,5	36	56,8	65,6	9,9	20,3	47,6	72,9	81,9
Water volume	l	1,3					1,7				
Heating mode, four pipes⁽³⁾											
Heating capacity	kW	3,64	5,20	8,43	11,16	12,13	4,14	6,31	10,54	13,74	14,80
Water flow	l/s	0,09	0,13	0,21	0,27	0,29	0,10	0,15	0,26	0,33	0,36
	l/h	320	460	740	980	1060	360	550	920	1200	1300
Water pressure drop	kPa	5,1	8,6	18,5	29,7	34,3	5,4	10,2	23,6	36,9	41,9
Water volume	l	0,7					0,9				
Electric heater											
		230V ±10% - 1ph - 50Hz					230V ±10% - 1ph - 50Hz				
Maximum capacity	W	3200					3200				
Current input	A	14,6					14,6				
Sound levels											
Sound power level (return and radiated)	dB(A)	41	48	57	63	64	41	48	57	63	64
Sound power level (supply)	dB(A)	42	48	58	66	68	42	48	58	66	68
Electrical data, motor											
Power input	W	174	227	282	316	356	174	227	282	316	356
Current input	A	0,84	1,08	1,40	1,74	1,86	0,84	1,08	1,40	1,74	1,86
FCEER [energy class] - 2 pipes		29 [D]					32 [D]				
FCCOP [energy class]		34 [D]					37 [D]				
FCEER [energy class] - 4 pipes		24 [E]					30 [D]				
FCCOP [energy class]		32 [D]					39 [D]				

Fan speed: L = Low, M = Medium, H = High



Eurovent certified values

(1) Eurovent conditions: inlet air temperature = 27 °C db/47 % RH – water inlet temperature = 7 °C, water temperature difference = 5 K.

(2) Eurovent conditions: inlet air temperature = 20 °C, water inlet temperature = 50 °C, water flow identical to cooling mode.

(3) Eurovent conditions: inlet air temperature = 20 °C, water inlet temperature = 70 °C, water temperature difference = 10K.

7 - 42NH AND 42NL PERFORMANCE DATA

42NH	739				749			
Fan speed	2V	7V	8V	10V	2V	7V	8V	10V
(Eurovent certification speeds)	(L)	(M)	(H)	Max	(L)	(M)	(H)	Max
Air flow	124	441	477	529	124	441	477	529
	l/s							
	m ³ /h	445	1586	1717	1906	445	1586	1717
Available static pressure	Pa	4	50	59	72	4	50	59
Cooling mode, two pipes⁽¹⁾								
Total cooling capacity	kW	2,79	8,84	9,34	10,00	2,97	9,94	10,56
Sensible cooling capacity	kW	2,16	6,99	7,43	8,01	2,25	7,60	8,11
Water flow	l/s	0,13	0,43	0,45	0,49	0,14	0,48	0,51
	l/h	480	1540	1630	1760	510	1730	1840
Water pressure drop	kPa	6,6	52,7	58,2	65,9	5,8	51,8	57,7
Water volume	l	2			2,6			
Heating mode, two pipes⁽²⁾								
Heating capacity	kW	3,22	10,51	11,31	12,42	3,22	11,19	12,07
Water flow	l/s	0,16	0,51	0,55	0,60	0,16	0,54	0,58
	l/h	560	1830	1970	2160	560	1950	2100
Water pressure drop	kPa	8,3	58	65,8	77,4	6,6	51,8	59,1
Water volume	l	2			2,6			
Cooling mode, four pipes⁽¹⁾								
Total cooling capacity	kW	2,51	7,33	7,75	8,31	2,89	9,36	9,86
Sensible cooling capacity	kW	2,02	6,10	6,48	6,99	2,21	7,27	7,71
Water flow	l/s	0,12	0,36	0,38	0,41	0,14	0,45	0,48
	l/h	430	1280	1360	1470	500	1630	1720
Water pressure drop	kPa	6,7	44,7	49,5	56,4	7,1	58,7	64,6
Water volume	l	1,3			1,7			
Heating mode, four pipes⁽³⁾								
Heating capacity	kW	3,07	9,65	10,28	11,11	3,36	12,02	12,75
Water flow	l/s	0,08	0,24	0,25	0,27	0,08	0,29	0,31
	l/h	270	850	900	970	290	1050	1120
Water pressure drop	kPa	4	23,3	25,9	29,5	4,1	29,4	32,5
Water volume	l	0,7			0,9			
Electric heater		230V ±10% - 1ph - 50Hz			230V ±10% - 1ph - 50Hz			
Maximum capacity	W	3000			3000			
Current input	A	13,7			13,7			
Sound levels								
Sound power level (return and radiated)	dB(A)	45	60	62	63	45	60	62
Sound power level (supply)	dB(A)	44	61	63	65	44	61	63
Electrical data, motor								
Power input	W	10	137	177	240	10	137	177
Current input	A	0,11	1,11	1,38	1,85	0,11	1,11	1,38
FCEER [energy class] - 2 pipes		87 [A]			96 [A]			
FCCOP [energy class]		109 [A]			113 [A]			
FCEER [energy class] - 4 pipes		75 [B]			92 [A]			
FCCOP [energy class]		101 [A]			120 [A]			

Fan speed: L = Low, M = Medium, H = High



Eurovent certified values

- (1) Eurovent conditions: inlet air temperature = 27 °C db/47 % RH – water inlet temperature = 7 °C, water temperature difference = 5 K.
 (2) Eurovent conditions: inlet air temperature = 20 °C, water inlet temperature = 50 °C, water flow identical to cooling mode.
 (3) Eurovent conditions: inlet air temperature = 20 °C, water inlet temperature = 70 °C, water temperature difference = 10K.

7 - 42NH AND 42NL PERFORMANCE DATA

7.8 - Electrical data

7.8.1 - 42NL

42NL 2-5 (AC multi-speed version)

Speed	I	P	Qv	Qv	ESP
	(A)	(W)	(l/s)	(m³/h)	G3 Filter (Pa)
R1	0,35	80	138	495	0
	0,35	80	136	490	3
	0,35	79	131	470	12
	0,35	79	125	450	19
	0,35	78	119	430	26
	0,35	77	114	410	33
	0,34	77	108	390	38
	0,34	76	103	370	44
	0,34	76	97	350	48
	0,34	75	92	330	53
	0,34	75	86	310	57
	0,34	75	81	290	60
R2	0,33	73	56	200	73
	0,28	65	125	450	0
	0,28	65	119	430	7
	0,28	64	114	410	14
	0,28	64	108	390	21
	0,27	63	103	370	27
	0,27	63	97	350	33
	0,27	62	92	330	38
	0,27	62	86	310	43
	0,27	61	81	290	48
	0,26	61	75	270	52
	0,26	60	69	250	56
R3	0,26	59	64	230	60
	0,26	59	58	210	63
	0,26	58	53	190	67
	0,26	58	47	170	70
	0,23	54	110	394	0
	0,23	53	103	370	10
	0,23	53	97	350	18
	0,23	52	92	330	25
	0,23	51	86	310	30
	0,23	51	81	290	35
	0,23	50	75	270	40
	0,22	50	69	250	44
R4	0,22	49	64	230	49
	0,22	49	58	210	53
	0,21	48	53	190	57
	0,21	48	47	170	62
	0,21	48	42	150	68
	0,20	45	96	345	0
	0,20	45	94	340	2
	0,20	45	89	320	9
	0,20	44	83	300	15
	0,19	44	78	280	21
	0,19	43	72	260	27
	R5	0,19	43	67	240
0,19		42	61	220	38
0,18		42	56	200	43
0,18		41	50	180	49
0,18		41	44	160	55
0,14		31	69	247	0
0,14		31	68	245	1
0,14		31	65	235	4
0,13		31	56	200	13
0,13		31	50	180	18
0,13		31	47	170	21
R6		0,13	31	44	160
	0,13	30	42	150	27
	0,13	30	39	140	30
	0,13	30	36	130	33
	0,13	29	33	120	36
	0,13	29	31	110	39
	0,12	28	61	211	0
	0,12	27	50	180	6
	0,12	27	47	170	8
	0,12	27	44	160	11
	0,12	27	42	150	13
	0,12	27	39	140	15
0,12	27	36	130	18	
0,12	27	28	100	26	

Key
I Current drawn by the fan motor
P Power input to the fan motor

42NL 2-9 (EC brushless motor)

Speed	I	P	Qv	Qv	ESP	
	(A)	(W)	(l/s)	(m³/h)	G3 Filter (Pa)	
10V	0,14	13	103	370	0	
	0,13	13	97	350	4	
	0,13	13	90	325	9	
	0,13	13	94	340	6	
	0,13	13	89	320	10	
	0,13	12	83	300	14	
	0,12	12	78	280	18	
	0,11	10	56	200	30	
	0,09	8	28	100	42	
	9V	0,12	12	97	350	0
		0,12	12	90	325	5
		0,12	11	83	300	10
0,12		11	76	275	15	
0,12		10	69	250	19	
0,11		10	63	225	23	
0,11		9	56	200	26	
0,10		9	49	175	29	
0,09		8	28	100	37	
8V		0,11	10	89	320	0
		0,11	10	83	300	4
		0,11	9	75	270	10
	0,10	9	67	240	14	
	0,10	8	58	210	19	
	0,09	8	50	180	22	
	0,09	7	42	150	26	
	0,09	7	33	120	30	
	0,08	7	25	90	33	
	7V	0,10	9	81	292	0
		0,10	8	76	275	3
		0,09	8	69	250	8
0,09		8	64	230	11	
0,09		7	58	210	14	
0,08		7	42	150	21	
0,08		6	28	100	26	
0,07		6	21	75	28	
6V		0,08	7	74	261	0
		0,07	7	69	250	2
		0,07	6	64	230	4
		0,07	6	58	210	7
	0,07	6	53	190	10	
	0,07	6	47	170	13	
	0,07	5	42	150	15	
	0,07	5	31	110	20	
	0,07	5	21	75	23	
	5V	0,06	5	65	235	0
		0,06	5	60	215	2
		0,06	5	56	200	4
0,06		5	50	180	7	
0,06		5	44	160	9	
0,06		5	39	140	11	
0,06		4	33	120	13	
0,06		4	28	100	15	
0,05		4	17	60	18	
4V		0,06	5	58	210	0
		0,06	4	56	200	1
		0,06	4	49	175	4
	0,06	4	42	150	7	
	0,06	4	35	125	10	
	0,06	4	28	100	12	
	0,06	4	21	75	14	
	0,05	3	14	50	16	
	3V	0,06	4	51	182	0
		0,06	3	47	170	1
		0,06	3	42	150	3
		0,05	3	28	100	8
0,05		3	14	50	11	
2V		0,05	3	43	155	0
	0,05	3	38	135	2	
	0,05	3	32	115	3	
	0,05	3	26	95	5	
	0,04	2	11	40	8	

Qv Air flow
ESP Available external static pressure
R Fixed speed

7 - 42NH AND 42NL PERFORMANCE DATA

42NL 3-5 (AC multi-speed version)

Speed	I	P	Qv	Qv	ESP
	(A)	(W)	(l/s)	(m³/h)	G3 Filter (Pa)
R1	0,44	99	168	605	0
	0,44	99	167	600	3
	0,43	98	161	580	11
	0,43	96	156	560	18
	0,42	95	150	540	25
	0,41	94	144	520	31
	0,41	93	139	500	37
	0,41	92	133	480	43
	0,40	91	128	460	48
	0,40	90	122	440	53
	0,39	90	117	420	58
	0,39	89	111	400	62
0,39	89	106	380	66	
0,39	88	100	360	70	
R2	0,37	86	154	555	0
	0,37	85	153	550	2
	0,36	84	147	530	11
	0,35	82	142	510	20
	0,35	81	136	490	27
	0,34	80	131	470	34
	0,34	79	125	450	40
	0,34	78	119	430	46
	0,33	77	114	410	51
	0,33	77	108	390	56
	0,33	76	103	370	61
	0,32	75	97	350	65
0,32	75	92	330	69	
0,32	75	90	325	70	
R3	0,32	74	143	515	0
	0,31	73	139	500	8
	0,31	72	133	480	16
	0,30	71	128	460	24
	0,30	70	122	440	31
	0,29	69	117	420	37
	0,29	68	111	400	43
	0,29	67	106	380	48
	0,28	66	100	360	53
	0,28	65	94	340	57
	0,28	64	89	320	62
	0,27	64	83	300	66
0,27	63	78	280	69	
R4	0,27	62	124	445	0
	0,27	62	122	440	4
	0,26	60	117	420	13
	0,26	59	111	400	22
	0,25	57	106	380	30
	0,25	57	100	360	37
	0,24	56	94	340	43
	0,24	55	89	320	48
	0,24	55	83	300	54
	0,24	54	78	280	58
	0,24	54	72	260	63
	0,23	54	67	240	67
R5	0,20	45	94	340	0
	0,19	44	89	320	7
	0,19	43	83	300	15
	0,18	42	78	280	22
	0,18	42	72	260	29
	0,18	41	67	240	36
	0,18	41	61	220	42
	0,18	41	56	200	48
R6	0,16	38	83	300	0
	0,16	37	78	280	7
	0,16	37	72	260	14
	0,16	37	67	240	20
	0,16	37	61	220	26
	0,16	36	56	200	32
	0,16	36	50	180	38
0,15	36	44	160	44	

Key

I Current drawn by the fan motor

R Fixed speed

P Power input to the fan motor

Qv Air flow rate

ESP Available external static pressure

42NL 3-9 (EC brushless motor)

Speed	I	P	Qv	Qv	ESP
	(A)	(W)	(l/s)	(m³/h)	G3 Filter (Pa)
10V	0,39	49	168	605	0
	0,39	49	167	600	2
	0,38	48	161	580	8
	0,37	47	156	560	14
	0,37	46	150	540	20
	0,36	45	144	520	27
	0,35	44	139	500	33
	0,34	43	133	480	39
	0,31	39	111	400	64
	9V	0,35	41	153	550
0,34		40	147	530	9
0,33		39	142	510	17
0,31		38	136	490	24
0,30		37	131	470	31
0,30		37	125	450	37
8V	0,29	36	119	430	43
	0,28	35	114	410	49
	0,27	33	103	370	59
	0,30	34	144	517	0
	0,30	34	142	510	3
	0,28	33	136	490	11
7V	0,27	32	131	470	19
	0,26	31	125	450	25
	0,25	31	119	430	31
	0,24	30	114	410	37
	0,23	27	97	350	51
	0,22	26	89	320	56
	0,27	33	133	480	0
	0,26	32	128	460	6
6V	0,25	31	122	440	13
	0,24	30	117	420	19
	0,24	29	111	400	24
	0,23	29	106	380	29
	0,23	28	100	360	33
	0,22	25	83	300	44
	0,20	23	69	250	53
	0,17	20	119	430	0
5V	0,16	19	111	400	8
	0,16	18	106	380	13
	0,16	18	100	360	17
	0,15	17	94	340	21
	0,15	16	83	300	28
	0,14	15	69	250	37
	0,13	14	56	200	46
	0,12	14	53	190	48
4V	0,14	15	103	370	0
	0,13	14	97	350	5
	0,13	14	92	330	10
	0,13	13	86	310	14
	0,12	13	81	290	18
	0,12	12	75	270	22
	0,12	12	69	250	25
	0,11	11	56	200	33
	0,09	10	42	150	42
	0,10	10	89	320	0
3V	0,10	9	83	300	4
	0,10	9	78	280	9
	0,09	9	72	260	12
	0,09	8	67	240	15
	0,09	8	61	220	18
	0,09	8	56	200	21
	0,09	7	42	150	26
	0,08	7	28	100	32
2V	0,08	7	69	250	0
	0,08	6	56	200	10
	0,07	6	42	150	16
	0,07	5	28	100	21
	0,05	4	14	50	26
	0,06	4	54	195	0
2V	0,06	4	42	150	6
	0,06	4	28	100	10
	0,05	3	14	50	13
	0,05	3	7	25	15

7 - 42NH AND 42NL PERFORMANCE DATA

42NL 4-5 (AC multi-speed version)

Speed	I	P	Qv	Qv	ESP
	(A)	(W)	(l/s)	(m ³ /h)	G3 Filter (Pa)
R1	0.69	157	299	1075	0
	0.69	156	292	1050	6
	0.68	155	278	1000	17
	0.68	154	264	950	26
	0.67	152	250	900	35
	0.67	150	236	850	42
	0.66	149	222	800	50
	0.65	147	208	750	56
	0.65	145	194	700	62
	0.64	144	181	650	68
0.63	142	167	600	73	
0.63	141	153	550	78	
R2	0.57	129	267	960	0
	0.57	129	264	950	3
	0.56	128	257	925	10
	0.56	127	250	900	16
	0.55	126	242	870	23
	0.55	125	233	840	29
	0.54	123	225	810	35
	0.54	122	217	780	40
	0.53	121	208	750	45
	0.52	118	181	650	59
0.51	116	167	600	65	
0.50	114	153	550	70	
R3	0.49	113	233	840	0
	0.49	111	228	820	7
	0.48	110	222	800	14
	0.48	109	217	780	20
	0.47	107	211	760	26
	0.47	106	206	740	31
	0.46	105	200	720	35
	0.46	104	194	700	39
	0.46	103	189	680	43
	0.45	103	183	660	46
0.45	102	178	640	49	
0.44	99	153	550	60	
R4	0.43	98	208	750	0
	0.42	96	201	725	9
	0.41	94	194	700	17
	0.40	92	188	675	24
	0.40	91	181	650	30
	0.39	89	174	625	35
	0.39	89	167	600	40
	0.38	88	160	575	44
	0.38	87	153	550	48
	0.38	87	146	525	51
0.38	86	139	500	55	
0.37	86	132	475	58	
R5	0.30	68	149	535	0
	0.30	68	147	530	3
	0.29	66	139	500	14
	0.29	65	133	480	20
	0.28	65	128	460	24
	0.28	64	122	440	28
	0.28	64	119	430	30
	0.28	64	117	420	31
	0.28	64	114	410	33
	0.28	64	111	400	35
0.28	64	108	390	36	
0.28	63	106	380	37	
R6	0.25	57	129	465	0
	0.25	57	125	450	5
	0.25	56	119	430	11
	0.25	56	114	410	17
	0.24	56	108	390	21
	0.24	55	103	370	25
	0.24	55	97	350	28
	0.24	55	92	330	31
	0.24	55	86	310	33

Key

I Current drawn by the fan motor
P Power input to the fan motor

42NL 4-9 (EC brushless motor)

Speed	I	P	Qv	Qv	ESP
	(A)	(W)	(l/s)	(m ³ /h)	G3 Filter (Pa)
10V	0.80	99	226	815	0
	0.79	99	222	800	7
	0.79	99	215	775	19
	0.79	99	208	750	31
	0.78	98	201	725	43
	0.77	97	194	700	54
	0.76	95	188	675	64
	0.74	93	181	650	74
	0.73	91	174	625	83
	0.75	91	217	780	0
9V	0.72	89	208	750	14
	0.70	87	201	725	26
	0.69	85	194	700	36
	0.67	83	188	675	46
	0.66	81	181	650	56
	0.64	79	174	625	65
	0.63	77	167	600	73
	0.61	75	160	575	81
	0.65	78	207	745	0
	0.63	76	201	725	8
8V	0.60	73	194	700	19
	0.58	71	188	675	29
	0.57	70	181	650	38
	0.56	68	174	625	46
	0.55	66	167	600	53
	0.54	65	160	575	60
	0.53	64	153	550	67
	0.54	58	192	690	0
	0.53	58	188	675	5
	0.50	57	181	650	13
7V	0.48	55	174	625	21
	0.46	54	167	600	28
	0.44	53	160	575	35
	0.43	52	153	550	42
	0.42	51	146	525	49
	0.41	49	139	500	55
	0.38	42	169	610	0
	0.37	42	167	600	3
	0.35	41	160	575	10
	0.33	40	153	550	17
6V	0.32	39	146	525	24
	0.31	38	139	500	31
	0.30	36	132	475	37
	0.30	35	125	450	44
	0.29	34	118	425	49
	0.29	30	150	540	0
	0.28	29	146	525	3
	0.27	28	139	500	9
	0.25	28	132	475	15
	0.24	27	125	450	21
5V	0.23	26	118	425	27
	0.22	25	111	400	32
	0.22	24	104	375	37
	0.21	23	97	350	41
	0.18	18	124	445	0
	0.17	18	118	425	4
	0.16	17	111	400	8
	0.15	17	104	375	13
	0.14	16	97	350	17
	0.14	15	90	325	21
4V	0.13	15	83	300	25
	0.13	14	76	275	28
	0.13	13	69	250	32
	0.12	11	97	350	0
	0.11	10	83	300	8
	0.10	9	69	250	15
	0.10	9	56	200	21
	0.09	8	42	150	26
	0.07	6	67	240	0
	0.07	5	56	200	4
3V	0.07	5	42	150	9
	0.06	4	28	100	12
	0.06	4	14	50	15
2V	0.07	5	42	150	9
	0.06	4	28	100	12
	0.06	4	14	50	15

Qv Air flow
ESP Available external static pressure
R Fixed speed

7 - 42NH AND 42NL PERFORMANCE DATA

42NL 5-5 (AC multi-speed version)

Speed	I	P	Qv	Qv	ESP
	(A)	(W)	(l/s)	(m ³ /h)	G3 Filter (Pa)
R1	0,74	170	358	1290	0
	0,74	169	354	1275	2
	0,73	168	347	1250	6
	0,73	167	340	1225	10
	0,73	166	333	1200	14
	0,72	164	319	1150	21
	0,71	162	306	1100	28
	0,70	160	292	1050	35
	0,69	158	278	1000	41
	0,69	156	264	950	48
	0,68	155	250	900	54
	0,66	150	208	750	71
R2	0,60	137	313	1125	0
	0,60	136	306	1100	5
	0,59	135	299	1075	9
	0,59	134	292	1050	13
	0,58	132	278	1000	21
	0,57	129	264	950	29
	0,56	128	250	900	37
	0,55	126	236	850	44
	0,54	124	222	800	51
	0,54	122	208	750	58
	0,53	121	194	700	64
	0,52	119	181	650	70
R3	0,52	118	275	990	0
	0,51	116	264	950	8
	0,50	115	257	925	13
	0,50	113	250	900	18
	0,49	112	243	875	23
	0,49	111	236	850	28
	0,48	110	229	825	32
	0,48	109	222	800	37
	0,47	108	215	775	41
	0,47	107	208	750	45
	0,46	106	194	700	53
	0,45	103	167	600	66
R4	0,43	99	233	840	0
	0,43	97	222	800	10
	0,42	95	215	775	15
	0,42	94	208	750	21
	0,41	94	201	725	26
	0,41	93	194	700	31
	0,40	92	188	675	35
	0,40	91	181	650	39
	0,40	90	174	625	43
	0,40	90	167	600	47
	0,39	89	160	575	51
	0,39	89	153	550	54
R5	0,30	67	169	610	0
	0,30	67	167	600	2
	0,30	67	160	575	8
	0,29	66	153	550	13
	0,29	66	146	525	17
	0,29	66	139	500	22
	0,29	65	132	475	26
	0,29	65	125	450	30
	0,28	64	118	425	34
	0,28	64	111	400	37
	0,28	64	104	375	41
	0,28	63	97	350	45
R6	0,26	58	149	535	0
	0,25	58	139	500	8
	0,25	57	132	475	12
	0,25	57	125	450	16
	0,25	57	118	425	20
	0,25	57	111	400	24
	0,25	56	104	375	27
	0,25	56	97	350	31
0,25	56	90	325	35	

Key

- I Current drawn by the fan motor
- P Power input to the fan motor

42NL 5-9 (EC brushless motor)

Speed	I	P	Qv	Qv	ESP
	(A)	(W)	(l/s)	(m ³ /h)	G3 Filter (Pa)
10V	0,39	58	254	915	0
	0,39	57	250	900	3
	0,37	55	236	850	11
	0,36	54	222	800	18
	0,35	52	208	750	26
	0,34	50	194	700	33
	0,33	49	181	650	41
	0,32	47	167	600	48
	0,29	44	139	500	62
	0,34	51	243	875	0
9V	0,34	50	236	850	4
	0,32	48	222	800	11
	0,31	46	208	750	18
	0,30	44	194	700	25
	0,28	42	181	650	32
	0,27	41	167	600	38
	0,26	39	153	550	45
8V	0,24	36	125	450	58
	0,28	43	229	825	0
	0,28	42	222	800	4
	0,26	39	208	750	10
	0,25	37	194	700	16
	0,24	36	181	650	23
	0,23	34	167	600	29
7V	0,22	33	153	550	35
	0,22	32	139	500	42
	0,20	30	111	400	54
	0,22	33	208	750	0
	0,21	31	194	700	6
	0,20	29	181	650	13
	0,19	28	167	600	19
6V	0,19	27	153	550	25
	0,18	26	139	500	31
	0,17	25	125	450	36
	0,17	24	111	400	42
	0,15	22	83	300	52
	0,17	24	186	670	0
	0,16	23	181	650	3
5V	0,16	22	167	600	9
	0,15	21	153	550	14
	0,14	20	139	500	20
	0,14	19	125	450	24
	0,13	18	111	400	29
	0,13	17	97	350	34
	0,11	15	69	250	42
4V	0,13	18	169	610	0
	0,13	17	167	600	1
	0,12	16	153	550	5
	0,12	16	139	500	10
	0,11	15	125	450	14
	0,11	14	111	400	19
	0,10	13	97	350	23
3V	0,10	13	83	300	27
	0,09	11	56	200	35
	0,09	11	139	500	0
	0,08	10	125	450	4
	0,08	10	111	400	8
	0,08	9	97	350	12
	0,07	9	83	300	16
2V	0,07	8	69	250	20
	0,07	8	56	200	23
	0,06	7	42	150	26
	0,06	7	28	100	29
	0,06	7	111	400	0
	0,06	7	97	350	4
	0,06	6	83	300	8
2V	0,06	6	69	250	11
	0,05	5	28	100	19
	0,04	4	83	295	0
	0,04	4	69	250	2
2V	0,04	4	56	200	5
	0,04	3	42	150	7
	0,04	3	28	100	9

- Qv Air flow
- ESP Available external static pressure
- R Fixed speed

7 - 42NH AND 42NL PERFORMANCE DATA

7.8.2 - 42NH

42NH 2-5 (AC multi-speed version)

Speed	I	P	Qv	Qv	ESP
	(A)	(W)	(l/s)	(m ³ /h)	G3 Filter (Pa)
R1	0,24	54	143	515	0
	0,24	54	142	510	3
	0,24	53	136	490	12
	0,24	53	131	470	20
	0,23	52	125	450	28
	0,23	51	119	430	35
	0,23	51	114	410	41
	0,22	50	108	390	47
	0,22	49	103	370	52
	0,21	48	97	350	57
	0,21	47	92	330	61
	0,19	43	69	250	74
R2	0,18	41	56	200	80
	0,17	39	42	150	85
	0,23	50	99	355	0
	0,22	48	93	335	12
	0,22	46	88	315	23
	0,21	45	82	295	32
	0,20	43	76	275	41
	0,20	42	71	255	49
	0,19	40	65	235	56
	0,18	39	60	215	62
	0,18	38	57	205	65
	0,18	37	54	195	68
R3	0,18	36	51	185	70
	0,17	36	49	175	72
	0,17	35	46	165	74
	0,17	35	43	155	76
	0,16	34	40	145	78
	0,16	33	38	135	80
	0,22	48	79	285	0
	0,22	47	74	265	12
	0,21	45	68	245	24
	0,20	44	65	235	29
	0,20	42	63	225	35
	0,20	41	60	215	39
R4	0,19	40	57	205	44
	0,19	39	54	195	49
	0,18	38	51	185	53
	0,18	37	49	175	56
	0,18	36	46	165	60
	0,17	35	43	155	63
	0,17	34	40	145	67
	0,16	33	38	135	69
	0,16	32	35	125	72
	0,16	20	54	195	0
	0,16	20	53	190	7
	R5	0,16	20	51	185
0,16		20	50	180	18
0,16		20	49	175	23
0,15		20	47	170	28
0,15		20	46	165	33
0,15		20	44	160	37
0,15		19	42	150	46
0,14		19	39	140	53
0,14		19	36	130	59
0,14		19	33	120	65
0,13		13	35	125	0
R5		0,13	13	32	115
	0,13	13	31	110	13
	0,13	13	29	105	17
	0,13	13	28	100	21
	0,13	13	26	95	25
	0,13	13	25	90	29
	0,12	13	24	85	33
	0,12	13	22	80	36
	0,12	13	21	75	40
	0,12	13	19	70	43
	0,12	13	18	65	46
	0,12	13	17	60	49

42NH 229 & 239 (EC brushless motor)

Speed	I	P	Qv	Qv	ESP	
	(A)	(W)	(l/s)	(m ³ /h)	G3 Filter (Pa)	
10V	0,39	47	169	610	0	
	0,38	47	167	600	2	
	0,36	44	153	550	15	
	0,35	42	139	500	29	
	0,33	40	125	450	43	
	0,31	37	111	400	57	
	0,29	35	97	350	70	
	0,26	32	69	250	90	
	0,25	30	42	150	101	
	9V	0,34	40	161	580	0
		0,31	37	139	500	19
		0,28	33	111	400	45
0,26		31	97	350	58	
0,25		29	83	300	70	
0,24		28	69	250	79	
0,23		26	56	200	86	
0,22		26	49	175	89	
0,22		26	42	150	91	
8V		0,28	32	147	530	0
		0,27	31	139	500	7
		0,26	30	133	480	12
	0,25	29	128	460	17	
	0,25	29	122	440	22	
	0,24	28	117	420	26	
	0,21	24	83	300	53	
	0,19	21	56	200	70	
	0,18	20	42	150	75	
	7V	0,22	24	133	480	0
		0,21	24	125	450	8
		0,20	23	111	400	20
0,19		21	97	350	30	
0,18		20	83	300	40	
0,16		18	69	250	48	
0,15		17	56	200	56	
0,14		15	42	150	62	
0,13		15	35	125	66	
6V		0,16	18	119	430	0
		0,16	18	111	400	6
		0,15	16	97	350	16
	0,14	15	83	300	25	
	0,13	14	69	250	34	
	0,12	13	56	200	41	
	0,11	12	42	150	47	
	0,11	11	35	125	50	
	0,10	11	28	100	52	
	5V	0,12	13	106	380	0
		0,12	13	97	350	5
		0,11	12	83	300	14
0,10		11	69	250	22	
0,09		10	56	200	29	
0,09		9	42	150	34	
0,08		8	35	125	37	
0,08		8	28	100	39	
0,08		7	25	90	40	
4V		0,09	10	90	325	0
		0,09	9	83	300	4
		0,09	9	78	280	7
	0,09	8	72	260	10	
	0,09	8	67	240	13	
	0,08	8	56	200	19	
	0,08	7	42	150	24	
	0,07	6	28	100	28	
	0,06	6	21	75	29	
	3V	0,07	6	72	260	0
		0,07	5	56	200	7
		0,07	5	39	140	14
0,06		4	28	100	17	
0,06		4	22	80	19	
2V		0,05	4	50	180	0
		0,05	3	44	160	4
		0,05	3	39	140	6
		0,05	3	28	100	9
		0,05	3	17	60	11

Key

I Current drawn by the fan motor
P Power input to the fan motor

Qv Air flow
ESP Available external static pressure

R Fixed speed

7 - 42NH AND 42NL PERFORMANCE DATA

42NH 279 (EC brushless motor)

Speed	I	P	Qv	Qv	ESP
	(A)	(W)	(l/s)	(m ³ /h)	G3 Filter (Pa)
10V	0,75	93	225	810	0
	0,75	93	222	800	3
	0,71	88	194	700	31
	0,69	85	181	650	46
	0,66	82	167	600	62
	0,63	78	153	550	77
	0,60	74	139	500	93
	0,57	71	125	450	109
0,55	67	111	400	124	
9V	0,65	81	213	767	0
	0,65	80	208	750	6
	0,63	78	194	700	20
	0,61	76	181	650	34
	0,59	73	167	600	49
	0,57	70	153	550	63
	0,54	66	139	500	78
	0,49	60	111	400	106
0,46	56	97	350	120	
8V	0,51	63	196	705	0
	0,51	63	194	700	1
	0,50	61	181	650	14
	0,48	59	167	600	27
	0,46	56	153	550	40
	0,44	53	139	500	54
	0,42	50	125	450	67
	0,37	45	97	350	93
0,34	40	69	250	117	
7V	0,40	48	176	635	0
	0,39	47	167	600	10
	0,38	45	153	550	22
	0,36	43	139	500	34
	0,34	41	125	450	46
	0,32	38	111	400	57
	0,30	36	97	350	67
	0,29	33	83	300	78
0,25	29	56	200	98	
6V	0,29	33	150	540	0
	0,27	32	139	500	11
	0,26	30	125	450	24
	0,24	28	111	400	34
	0,23	26	97	350	44
	0,21	24	83	300	53
	0,20	23	69	250	61
	0,19	21	56	200	70
0,18	20	42	150	78	
5V	0,20	22	129	465	0
	0,20	22	125	450	4
	0,18	21	111	400	15
	0,17	19	97	350	24
	0,16	18	83	300	32
	0,15	16	69	250	40
	0,14	15	56	200	47
	0,13	14	42	150	54
0,12	13	28	100	60	
4V	0,13	15	110	395	0
	0,12	14	97	350	8
	0,12	13	83	300	16
	0,11	12	69	250	24
	0,10	11	56	200	30
	0,10	11	49	175	33
	0,10	10	42	150	36
	0,09	9	35	125	38
0,09	9	28	100	40	
3V	0,08	8	83	300	0
	0,08	8	69	250	7
	0,07	7	56	200	13
	0,07	6	42	150	19
	0,06	5	14	50	27
2V	0,06	5	61	200	0
	0,05	5	47	170	4
	0,05	4	33	120	8
	0,05	4	19	70	12
0,05	3	6	20	14	

42NH 289 (EC brushless motor)

Speed	I	P	Qv	Qv	ESP
	(A)	(W)	(l/s)	(m ³ /h)	G3 Filter (Pa)
10V	0,91	116	207	745	0
	0,90	114	201	725	8
	0,88	112	194	700	17
	0,84	107	181	650	37
	0,80	102	167	600	56
	0,75	96	153	550	75
	0,71	91	139	500	93
	0,64	82	111	400	123
	0,60	76	83	300	142
	0,85	108	203	725	0
	0,83	105	194	700	9
	0,79	101	181	650	26
9V	0,75	95	167	600	45
	0,70	90	153	550	64
	0,66	85	139	500	83
	0,62	80	125	450	100
	0,59	76	111	400	115
	0,55	71	83	300	132
	0,68	85	194	680	0
	0,67	84	181	650	10
	0,65	82	167	600	24
	0,62	78	153	550	40
	0,58	73	139	500	58
	0,54	69	125	450	76
8V	0,50	64	111	400	93
	0,47	60	97	350	107
	0,45	56	83	300	118
	0,51	64	164	595	0
	0,49	62	153	550	13
	0,46	58	139	500	28
	0,43	54	125	450	45
	0,40	50	111	400	61
	0,37	46	97	350	76
	0,34	42	83	300	89
	0,32	40	69	250	100
	0,31	38	56	200	106
7V	0,38	47	140	505	0
	0,36	45	132	475	11
	0,34	42	118	425	28
	0,31	38	104	375	44
	0,28	35	90	325	58
	0,26	32	76	275	70
	0,25	30	63	225	80
	0,24	29	49	175	85
	0,18	20	42	150	78
	0,27	33	124	445	0
	0,26	32	118	425	6
	0,25	31	111	400	12
6V	0,23	28	97	350	26
	0,21	25	83	300	39
	0,19	23	69	250	50
	0,18	21	56	200	59
	0,17	20	42	150	64
	0,12	13	28	100	60
	0,18	21	100	360	0
	0,18	21	97	350	3
	0,16	19	83	300	15
	0,15	17	69	250	26
	0,14	16	63	225	31
	0,14	16	56	200	35
0,13	15	49	175	39	
0,12	14	42	150	43	
0,12	13	35	125	46	
5V	0,12	13	72	260	0
	0,11	12	56	200	10
	0,10	11	42	150	19
	0,09	9	28	100	28
	0,08	8	22	80	31
	0,08	7	46	165	0
4V	0,08	7	42	150	3
	0,07	7	35	125	8
	0,07	6	28	100	13
	0,06	5	14	50	20
3V	0,08	7	46	165	0
	0,08	7	42	150	3
	0,07	7	35	125	8
	0,07	6	28	100	13
2V	0,06	5	14	50	20

7 - 42NH AND 42NL PERFORMANCE DATA

42NH 3-5 (AC multi-speed version)

Speed	I	P	Qv	Qv	ESP
	(A)	(W)	(l/s)	(m³/h)	G3 Filter (Pa)
R1	0,88	201	199	716	0
	0,88	201	194	700	12
	0,88	200	192	690	20
	0,88	200	189	680	28
	0,87	199	186	670	37
	0,87	198	183	660	46
	0,87	197	181	650	56
	0,85	195	174	625	80
	0,84	192	167	600	105
	0,82	190	160	575	129
	0,81	186	153	550	151
	0,79	183	146	525	170
0,77	179	139	500	186	
0,76	175	132	475	198	
0,75	173	159	572	0	
0,75	173	158	570	2	
0,75	173	153	550	16	
0,75	172	147	530	32	
0,75	171	142	510	49	
R2	0,74	170	136	490	66
	0,73	168	131	470	84
	0,72	166	125	450	101
	0,71	164	119	430	118
	0,70	161	114	410	133
	0,69	158	108	390	146
	0,68	155	103	370	157
	0,67	152	97	350	166
	0,64	145	86	310	172
	0,65	150	124	448	0
0,65	150	124	445	2	
0,65	148	111	400	30	
0,64	147	106	380	41	
0,64	146	100	360	52	
0,63	144	94	340	64	
0,63	143	89	320	77	
0,62	141	83	300	91	
0,62	140	81	290	99	
0,61	139	78	280	108	
0,61	138	75	270	115	
0,61	137	72	260	121	
0,57	129	94	340	0	
0,57	128	88	315	16	
0,57	127	83	300	23	
0,56	127	81	290	27	
0,56	126	78	280	31	
0,56	125	75	270	35	
0,56	125	72	260	38	
0,56	124	69	250	43	
0,55	124	67	240	47	
0,55	124	64	230	51	
0,55	123	61	220	55	
0,55	123	58	210	61	
0,55	124	50	180	75	
0,50	111	65	233	0	
0,49	110	63	225	4	
0,49	109	56	200	15	
0,49	109	53	190	18	
0,49	109	50	180	21	
0,49	108	47	170	24	
0,49	108	44	160	27	
0,48	107	39	140	34	
0,48	107	33	120	42	
0,48	107	28	100	50	

Key

- I Current drawn by the fan motor
- P Power input to the fan motor
- Qv Air flow rate
- ESP Available external static pressure
- R Fixed speed

42NH 3-9 (EC brushless motor)

Speed	I	P	Qv	Qv	ESP		
	(A)	(W)	(l/s)	(m³/h)	G3 Filter (Pa)		
10V	1,34	174	278	1000	0		
	1,34	174	264	950	35		
	1,34	174	250	900	66		
	1,34	174	236	850	95		
	1,34	174	222	800	124		
	1,33	173	208	750	151		
	1,33	173	194	700	177		
	1,32	172	181	650	201		
	1,32	172	153	550	242		
	1,34	174	278	1000	0		
	1,34	174	264	950	35		
	1,34	174	250	900	66		
9V	1,34	174	236	850	95		
	1,34	174	222	800	124		
	1,33	173	208	750	151		
	1,33	173	194	700	177		
	1,32	172	167	600	223		
	1,32	172	153	550	242		
	1,34	174	278	1000	0		
	1,34	174	264	950	35		
	1,34	174	250	900	66		
	1,34	174	236	850	95		
	1,34	174	222	800	124		
	1,33	173	208	750	151		
1,33	173	194	700	177			
1,32	172	167	600	223			
1,32	172	153	550	242			
8V	1,34	174	278	1000	0		
	1,34	174	264	950	35		
	1,34	174	250	900	66		
	1,34	174	236	850	95		
	1,34	174	222	800	124		
	1,33	173	208	750	151		
	1,33	173	194	700	177		
	1,32	172	167	600	223		
	1,32	172	139	500	258		
	1,23	167	275	989	0		
	1,23	167	271	975	7		
	1,22	165	264	950	20		
1,20	161	250	900	45			
1,11	151	222	800	93			
1,01	140	194	700	137			
0,95	129	167	600	174			
0,91	122	139	500	201			
0,90	120	111	400	216			
7V	0,98	136	263	945	0		
	0,95	128	236	850	36		
	0,91	123	222	800	56		
	0,89	118	208	750	75		
	0,82	113	194	700	93		
	0,70	103	167	600	125		
	0,68	93	139	500	149		
	0,61	86	111	400	161		
	0,58	81	83	300	159		
	0,69	100	235	845	0		
	0,68	92	222	800	12		
	0,59	82	194	700	42		
0,55	75	167	600	73			
0,50	69	139	500	102			
0,45	62	111	400	127			
0,33	45	69	250	149			
0,31	41	63	225	150			
0,28	36	56	200	151			
6V	0,41	57	197	710	0		
	0,41	57	194	700	3		
	0,35	51	167	600	28		
	0,35	44	139	500	52		
	0,31	38	111	400	73		
	0,27	34	83	300	90		
	0,25	32	56	200	101		
	0,24	32	42	150	105		
	0,24	32	36	130	105		
	0,25	30	153	550	0		
	0,24	28	139	500	10		
	0,22	24	111	400	30		
0,17	19	69	250	54			
0,14	15	28	100	63			
5V	0,08	9	83	300	0		
	0,08	8	69	250	7		
	0,08	8	56	200	13		
	0,07	7	42	150	18		
	0,07	7	28	100	23		
	4V	0,08	9	83	300	0	
		0,08	8	69	250	7	
		0,08	8	56	200	13	
		0,07	7	42	150	18	
		0,07	7	28	100	23	
		3V	0,08	9	83	300	0
			0,08	8	69	250	7
0,08			8	56	200	13	
0,07			7	42	150	18	
0,07			7	28	100	23	
2V			0,08	9	83	300	0
			0,08	8	69	250	7
	0,08		8	56	200	13	
	0,07		7	42	150	18	
	0,07		7	28	100	23	

7 - 42NH AND 42NL PERFORMANCE DATA

42NH 4-5 (AC multi-speed version)

Speed	I	P	Qv	Qv	ESP
	(A)	(W)	(l/s)	(m³/h)	G3 Filter (Pa)
R1	0,72	161	369	1330	0
	0,71	158	361	1300	6
	0,67	150	333	1200	25
	0,63	142	306	1100	42
	0,60	134	278	1000	58
	0,58	128	250	900	73
	0,56	125	236	850	80
	0,55	122	222	800	87
	0,54	119	208	750	93
	0,53	117	194	700	99
	0,52	114	181	650	106
	0,50	112	167	600	111
	0,49	109	153	550	117
	0,47	105	125	450	128
R2	0,67	148	325	1170	0
	0,65	145	319	1150	5
	0,60	134	292	1050	27
	0,55	123	264	950	47
	0,52	115	236	850	64
	0,49	107	208	750	80
	0,47	104	194	700	87
	0,46	101	181	650	94
	0,44	98	167	600	101
	0,43	95	153	550	107
	0,42	93	139	500	113
	0,40	90	125	450	120
	0,40	89	118	425	123
	0,39	88	111	400	126
R3	0,62	133	246	885	0
	0,57	124	236	850	16
	0,54	119	229	825	26
	0,52	114	222	800	36
	0,50	110	215	775	44
	0,48	107	208	750	51
	0,46	101	194	700	63
	0,44	97	181	650	73
	0,43	94	167	600	80
	0,41	91	153	550	87
	0,40	88	139	500	95
	0,38	84	125	450	103
	0,37	82	118	425	107
	0,36	79	111	400	113
R4	0,51	109	171	615	0
	0,49	104	167	600	12
	0,46	98	160	575	29
	0,44	94	153	550	44
	0,42	90	146	525	55
	0,40	86	139	500	65
	0,39	84	132	475	72
	0,38	82	125	450	79
	0,37	80	118	425	84
	0,36	78	111	400	89
	0,35	76	104	375	94
	0,34	74	97	350	99
	0,33	71	90	325	104
	0,31	68	83	300	111
R5	0,43	87	115	415	0
	0,42	86	111	400	8
	0,41	85	108	390	15
	0,40	84	106	380	21
	0,39	82	103	370	28
	0,39	81	100	360	36
	0,38	79	97	350	43
	0,37	78	94	340	50
	0,36	76	92	330	57
	0,35	75	89	320	63
	0,35	73	86	310	69
	0,34	72	83	300	74
	0,33	71	81	290	78
	0,32	70	78	280	81

Key

- I Current drawn by the fan motor
- P Power input to the fan motor
- Qv Air flow rate
- ESP Available external static pressure
- R Fixed speed

42NH 4-9 (EC brushless motor)

Speed	I	P	Qv	Qv	ESP
	(A)	(W)	(l/s)	(m³/h)	G3 Filter (Pa)
10V	1,34	174	292	1050	0
	1,34	174	278	1000	25
	1,34	173	264	950	54
	1,34	174	250	900	82
	1,34	174	236	850	109
	1,33	174	222	800	136
	1,33	173	208	750	163
	1,32	173	194	700	188
	1,32	172	181	650	214
	9V	1,34	174	292	1050
1,34		174	278	1000	25
1,34		173	264	950	54
1,34		174	250	900	82
1,34		174	236	850	109
1,33		174	222	800	136
1,33		173	208	750	163
1,32		173	194	700	188
1,32		172	181	650	214
8V		1,34	174	292	1050
	1,34	174	278	1000	25
	1,34	173	264	950	54
	1,34	174	250	900	82
	1,34	174	236	850	109
	1,33	174	222	800	136
	1,33	173	208	750	163
	1,32	173	194	700	188
	1,32	172	181	650	214
	7V	1,29	169	291	1046
1,28		167	271	975	40
1,25		165	264	950	54
1,12		157	236	850	103
1,10		145	208	750	140
1,02		134	181	650	168
0,94		125	153	550	190
0,93		122	139	500	198
0,92		120	125	450	206
6V		1,04	140	275	991
	1,01	133	250	900	38
	0,98	128	236	850	58
	0,93	123	222	800	76
	0,90	118	208	750	93
	0,86	113	194	700	108
	0,78	103	167	600	135
	0,71	93	139	500	158
	0,65	86	111	400	177
	5V	0,82	108	252	906
0,71		92	222	800	33
0,69		89	215	775	41
0,66		87	208	750	48
0,60		79	181	650	72
0,56		72	153	550	92
0,51		66	125	450	109
0,49		62	111	400	117
0,46		58	97	350	125
4V		0,46	58	211	759
	0,41	51	181	650	26
	0,39	49	167	600	38
	0,37	46	153	550	48
	0,35	43	139	500	58
	0,32	40	125	450	66
	0,30	37	111	400	74
	0,30	35	104	375	77
	0,29	34	97	350	81
	3V	0,25	31	167	600
0,23		27	139	500	18
0,22		24	111	400	34
0,19		20	83	300	46
0,18		19	76	275	49
2V	0,10	10	91	327	0
	0,10	9	69	250	8
	0,09	8	56	200	12
	0,08	7	42	150	16
	0,08	7	35	125	17

7 - 42NH AND 42NL PERFORMANCE DATA

42NH 5-5 (AC multi-speed version)

Speed	I	P	Qv	Qv	ESP
	(A)	(W)	(l/s)	(m³/h)	G3 Filter (Pa)
R1	0,76	168	403	1450	0
	0,74	163	389	1400	9
	0,70	154	361	1300	26
	0,67	147	333	1200	41
	0,64	140	306	1100	55
	0,61	134	278	1000	68
	0,59	128	250	900	80
	0,57	123	222	800	92
	0,54	118	194	700	105
	0,53	113	167	600	117
	0,51	108	139	500	131
	0,50	105	125	450	138
0,49	103	111	400	146	
R2	0,71	156	378	1360	0
	0,69	152	361	1300	11
	0,65	143	333	1200	28
	0,61	135	306	1100	43
	0,57	126	278	1000	57
	0,54	119	250	900	71
	0,51	112	222	800	85
	0,48	106	194	700	98
	0,48	103	167	600	112
	0,48	101	139	500	127
	0,49	102	125	450	135
	0,50	103	111	400	143
R3	0,67	147	343	1235	0
	0,65	143	333	1200	8
	0,63	137	319	1150	18
	0,60	132	306	1100	28
	0,58	128	292	1050	37
	0,56	123	278	1000	45
	0,54	119	264	950	53
	0,52	115	250	900	60
	0,51	111	236	850	67
	0,49	108	222	800	74
	0,47	101	194	700	88
	0,44	95	167	600	103
0,41	90	139	500	119	
0,39	85	111	400	137	
R4	0,64	137	299	1075	0
	0,63	134	292	1050	7
	0,59	127	278	1000	20
	0,56	122	264	950	32
	0,54	116	250	900	43
	0,51	111	236	850	52
	0,49	107	222	800	61
	0,47	103	208	750	70
	0,46	100	194	700	77
	0,45	97	181	650	85
	0,43	92	153	550	98
	0,41	89	111	400	122
R5	0,59	123	247	890	0
	0,55	116	236	850	15
	0,51	109	222	800	31
	0,48	104	208	750	45
	0,46	99	194	700	56
	0,44	95	181	650	66
	0,42	92	167	600	75
	0,41	89	153	550	83
	0,39	86	139	500	91
	0,38	84	132	475	95
	0,37	82	125	450	99
	0,35	77	111	400	108

Key
I Current drawn by the fan motor
P Power input to the fan motor
Qv Air flow rate
ESP Available external static pressure
R Fixed speed

42NH 5-9 (EC brushless motor)

Speed	I	P	Qv	Qv	ESP	
	(A)	(W)	(l/s)	(m³/h)	G3 Filter (Pa)	
10V	1,88	252	513	1845	0	
	1,88	252	500	1800	17	
	1,88	252	472	1700	51	
	1,88	249	444	1600	77	
	1,87	242	417	1500	98	
	1,80	232	389	1400	114	
	1,72	219	361	1300	127	
	1,52	190	306	1100	151	
	1,31	159	250	900	181	
	9V	1,85	236	506	1820	0
		1,84	235	500	1800	5
		1,79	228	472	1700	30
1,73		221	444	1600	53	
1,68		213	417	1500	74	
1,62		205	389	1400	92	
8V	1,49	187	333	1200	125	
	1,35	167	278	1000	152	
	1,21	147	222	800	176	
	1,58	198	481	1730	0	
	1,56	195	472	1700	6	
	1,49	187	444	1600	24	
7V	1,43	178	417	1500	42	
	1,31	162	361	1300	75	
	1,20	146	306	1100	105	
	1,08	130	250	900	132	
	0,97	115	194	700	154	
	0,85	100	139	500	172	
6V	1,27	156	431	1550	0	
	1,22	150	417	1500	9	
	1,15	139	389	1400	26	
	1,08	130	361	1300	43	
	1,03	123	333	1200	58	
	0,98	116	306	1100	72	
5V	0,93	110	278	1000	86	
	0,84	98	222	800	108	
	0,65	73	139	500	134	
	0,95	112	383	1380	0	
	0,92	108	375	1350	5	
	0,89	103	361	1300	12	
4V	0,77	89	306	1100	39	
	0,73	83	278	1000	52	
	0,69	79	250	900	63	
	0,66	74	222	800	74	
	0,62	70	194	700	84	
	0,45	49	111	400	108	
3V	0,69	100	235	845	0	
	0,68	92	222	800	12	
	0,59	82	194	700	42	
	0,55	75	167	600	73	
	0,50	69	139	500	102	
	0,45	62	111	400	127	
2V	0,33	45	69	250	149	
	0,31	41	63	225	150	
	0,28	36	56	200	151	
	0,49	54	281	1010	0	
	0,48	53	278	1000	1	
	0,39	42	250	900	11	
1V	0,32	34	222	800	21	
	0,28	29	194	700	29	
	0,25	26	167	600	37	
	0,24	25	139	500	44	
	0,25	25	111	400	49	
	0,26	26	83	300	54	
0.5V	0,24	25	213	765	0	
	0,24	24	208	750	2	
	0,22	23	194	700	6	
	0,19	18	139	500	21	
	0,14	14	69	250	33	
	0,12	11	143	515	0	
0.2V	0,12	11	139	500	1	
	0,11	10	111	400	7	
	0,10	9	83	300	12	
	0,09	7	42	150	18	

7 - 42NH AND 42NL PERFORMANCE DATA

42NH 6-5 (AC multi-speed version)

Speed	I	P	Qv	Qv	ESP
	(A)	(W)	(l/s)	(m ³ /h)	G3 Filter (Pa)
R1	1,55	350	643	2315	0
	1,55	348	639	2300	4
	1,48	334	611	2200	23
	1,43	321	583	2100	40
	1,37	309	556	2000	55
	1,32	297	528	1900	67
	1,27	286	500	1800	78
	1,22	276	472	1700	88
	1,18	266	444	1600	96
	1,14	257	417	1500	103
	1,10	248	389	1400	109
	1,06	239	361	1300	115
0,95	215	278	1000	132	
R2	1,38	298	556	2000	1
	1,29	280	528	1900	31
	1,22	263	500	1800	52
	1,15	248	472	1700	66
	1,08	234	444	1600	77
	1,03	222	417	1500	85
	0,97	211	389	1400	92
	0,92	200	361	1300	99
	0,88	190	333	1200	107
	0,83	180	306	1100	116
	0,79	170	278	1000	125
	0,74	161	250	900	133
0,70	151	222	800	139	
R3	1,28	274	454	1635	0
	1,24	264	444	1600	13
	1,12	240	417	1500	41
	1,07	229	403	1450	51
	1,03	220	389	1400	60
	0,99	211	375	1350	66
	0,95	203	361	1300	73
	0,92	196	347	1250	78
	0,88	189	333	1200	84
	0,86	183	319	1150	90
	0,83	177	306	1100	95
	0,78	167	278	1000	107
0,67	144	222	800	126	
R4	1,11	227	305	1097	0
	1,06	218	299	1075	31
	1,02	209	292	1050	53
	0,98	201	285	1025	65
	0,95	194	278	1000	72
	0,92	188	271	975	76
	0,89	183	264	950	80
	0,87	179	257	925	85
	0,86	175	250	900	89
	0,84	172	243	875	94
	0,83	169	236	850	99
	0,81	166	229	825	104
R5	0,96	188	201	723	0
	0,94	183	199	715	23
	0,89	175	194	700	50
	0,87	170	192	690	59
	0,85	166	189	680	65
	0,83	163	186	670	69
	0,82	160	183	660	73
	0,81	158	181	650	77
	0,79	155	178	640	82
	0,78	153	175	630	87
	0,77	151	172	620	91
	0,76	149	169	610	96

Key

- I Current drawn by the fan motor
- P Power input to the fan motor
- Qv Air flow rate
- ESP Available external static pressure
- R Fixed speed

42NH 6-9 (EC brushless motor)

Speed	I	P	Qv	Qv	ESP	
	(A)	(W)	(l/s)	(m ³ /h)	G3 Filter (Pa)	
10V	2,01	280	522	1880	0	
	1,97	275	514	1850	8	
	1,91	266	500	1800	21	
	1,80	251	472	1700	45	
	1,72	239	444	1600	67	
	1,65	229	417	1500	87	
	1,59	221	389	1400	105	
	1,54	213	361	1300	121	
	1,35	183	278	1000	157	
	9V	1,77	238	506	1820	0
		1,75	235	500	1800	4
		1,64	221	472	1700	26
1,56		209	444	1600	45	
1,49		200	417	1500	63	
1,44		192	389	1400	80	
1,34		177	333	1200	110	
1,22		161	278	1000	138	
1,13		150	250	900	151	
8V		1,42	194	450	1620	0
		1,39	190	444	1600	4
		1,22	167	403	1450	37
	1,11	152	361	1300	64	
	1,04	141	319	1150	86	
	0,98	133	278	1000	105	
	0,92	124	236	850	121	
	0,83	111	194	700	137	
	0,69	92	153	550	152	
	7V	1,02	141	403	1450	0
		0,97	133	389	1400	10
		0,89	121	361	1300	29
0,83		112	333	1200	46	
0,79		106	306	1100	61	
0,75		102	278	1000	74	
0,72		98	250	900	86	
0,67		92	208	750	101	
0,43		54	111	400	124	
6V		0,71	93	361	1300	0
		0,68	88	333	1200	18
		0,64	83	306	1100	33
	0,60	78	278	1000	46	
	0,55	73	250	900	56	
	0,51	68	222	800	65	
	0,47	63	194	700	75	
	0,44	58	167	600	85	
	0,39	45	97	350	105	
	5V	0,50	69	319	1150	0
		0,49	65	306	1100	6
		0,46	59	278	1000	19
0,43		54	250	900	30	
0,40		50	222	800	40	
0,38		47	194	700	48	
0,35		43	167	600	56	
0,32		39	139	500	63	
0,24		28	83	300	72	
4V		0,35	46	256	920	0
		0,33	44	250	900	3
		0,28	36	222	800	14
	0,25	31	194	700	23	
	0,23	29	167	600	30	
	0,22	28	139	500	36	
	0,21	25	111	400	42	
	0,18	21	83	300	47	
	0,17	19	75	270	49	
	3V	0,19	22	194	700	0
		0,16	19	167	600	9
		0,14	17	139	500	16
0,13		15	111	400	21	
0,11		12	56	200	29	
2V		0,09	10	139	500	0
		0,09	10	125	450	3
		0,08	9	97	350	8
		0,08	8	69	250	12
		0,07	7	42	150	15

7 - 42NH AND 42NL PERFORMANCE DATA

42NH7-5 (AC multi-speed version)

Speed	I	P	Qv	Qv	ESP
	(A)	(W)	(l/s)	(m³/h)	G3 Filter (Pa)
R1	2,03	456	785	2830	0
	2,01	451	778	2800	3
	1,94	435	750	2700	14
	1,87	419	722	2600	24
	1,80	404	694	2500	34
	1,73	390	667	2400	43
	1,61	361	611	2200	60
	1,49	335	556	2000	76
	1,38	311	500	1800	90
	1,27	287	444	1600	103
	1,18	266	389	1400	115
	1,09	246	333	1200	127
1,00	227	278	1000	138	
R2	1,74	385	629	2265	0
	1,68	371	611	2200	10
	1,59	350	583	2100	24
	1,50	331	556	2000	38
	1,42	313	528	1900	50
	1,34	296	500	1800	61
	1,27	281	472	1700	72
	1,20	266	444	1600	81
	1,14	252	417	1500	90
	1,09	240	389	1400	98
	1,03	228	361	1300	106
	0,98	217	333	1200	113
0,82	180	222	800	138	
R3	1,40	302	390	1405	0
	1,39	300	389	1400	2
	1,24	267	361	1300	39
	1,11	239	333	1200	67
	1,00	216	306	1100	88
	0,91	197	278	1000	102
	0,87	189	264	950	108
	0,84	182	250	900	113
	0,81	175	236	850	118
	0,78	169	222	800	122
	0,76	164	208	750	127
	R4	1,08	229	219	790
1,06		224	217	780	16
1,04		219	214	770	30
1,01		215	211	760	43
0,99		210	208	750	54
0,97		206	206	740	64
0,95		202	203	730	72
0,93		198	200	720	80
0,93		196	199	715	83
0,92		194	197	710	86
0,90		190	194	700	92
0,83		175	181	650	108
0,77	163	167	600	114	
R5	0,84	175	149	537	0
	0,83	172	147	530	9
	0,81	169	144	520	21
	0,80	165	142	510	32
	0,78	162	139	500	42
	0,77	159	136	490	52
	0,75	156	133	480	60
	0,74	153	131	470	68
	0,73	151	128	460	75
	0,71	148	125	450	81
	0,70	146	122	440	87

Key
I Current drawn by the fan motor
P Power input to the fan motor
Qv Air flow rate
ESP Available external static pressure
R Fixed speed

42NH 7-9 (EC brushless motor)

Speed	I	P	Qv	Qv	ESP
	(A)	(W)	(l/s)	(m³/h)	G3 Filter (Pa)
10V	1,85	247	635	2285	0
	1,79	247	625	2250	9
	1,78	246	583	2100	40
	1,71	236	528	1900	72
	1,60	219	472	1700	94
	1,38	185	389	1400	114
	1,11	148	306	1100	126
	0,86	114	222	800	136
9V	1,78	247	635	2285	0
	1,79	247	625	2250	9
	1,78	246	583	2100	40
	1,71	236	528	1900	72
	1,60	219	472	1700	94
	1,38	185	389	1400	114
	1,11	148	306	1100	126
	0,86	114	222	800	136
8V	1,38	187	547	1980	0
	1,38	186	542	1960	6
	1,36	185	528	1900	19
	1,30	176	472	1700	59
	1,23	166	417	1500	86
	1,15	154	361	1300	104
	1,04	140	306	1100	117
	0,93	123	250	900	128
0,86	114	222	800	134	
7V	1,11	142	517	1860	0
	1,11	142	514	1850	2
	1,11	142	500	1800	13
	1,06	137	444	1600	48
	0,98	129	389	1400	70
	0,89	119	333	1200	85
	0,80	107	278	1000	97
	0,71	94	222	800	109
0,67	88	194	700	115	
6V	0,85	106	469	1690	1
	0,84	106	458	1650	8
	0,84	105	444	1600	16
	0,82	103	417	1500	30
	0,79	100	389	1400	42
	0,76	96	361	1300	51
	0,73	91	333	1200	59
	0,66	82	278	1000	71
0,51	61	167	600	95	
5V	0,59	72	406	1460	0
	0,58	72	389	1400	10
	0,57	70	361	1300	22
	0,54	67	333	1200	32
	0,52	64	306	1100	40
	0,49	59	278	1000	45
	0,46	55	250	900	49
	0,42	51	222	800	53
0,34	41	139	500	69	
4V	0,38	45	329	1185	0
	0,37	44	319	1150	5
	0,35	41	278	1000	21
	0,33	39	250	900	28
	0,31	36	222	800	32
	0,29	34	194	700	36
	0,27	31	167	600	41
	0,22	25	111	400	50
0,26	26	83	300	54	
3V	0,22	25	247	890	1
	0,21	23	222	800	11
	0,18	20	167	600	21
	0,16	18	111	400	28
2V	0,16	17	83	300	31
	0,11	11	164	590	0
	0,11	11	153	550	4
	0,10	10	139	500	8
	0,10	9	111	400	12
	0,08	7	56	200	18

7 - 42NH AND 42NL PERFORMANCE DATA

7.9 - Air flow data

Static pressure available (Pa) as a function of the air flow, m³/h (l/s)

7.9.1 - 42NL range

42NL 2-5 (with G3 filter)

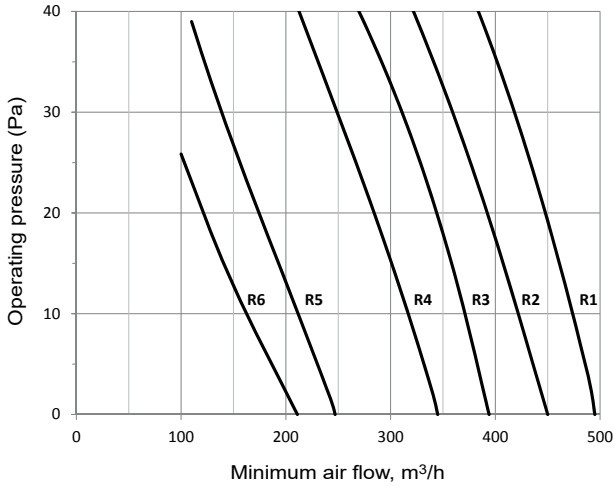

42NL 2-9 (with G3 filter)

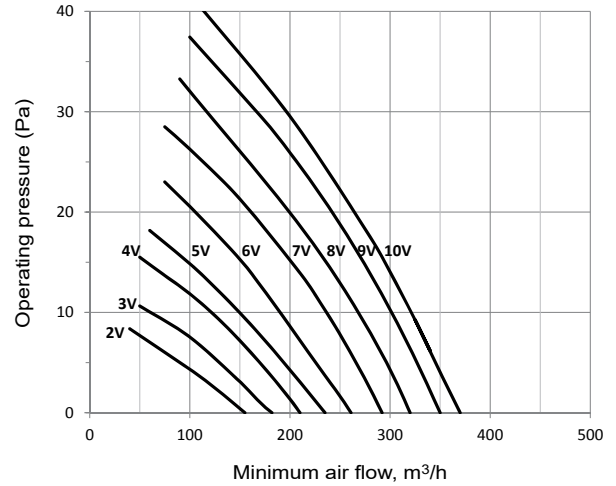

42NL 3-5 (with G3 filter)

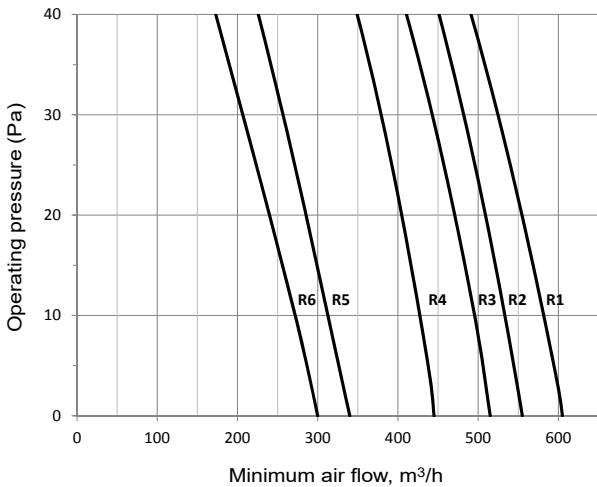

42NL 3-9 (with G3 filter)

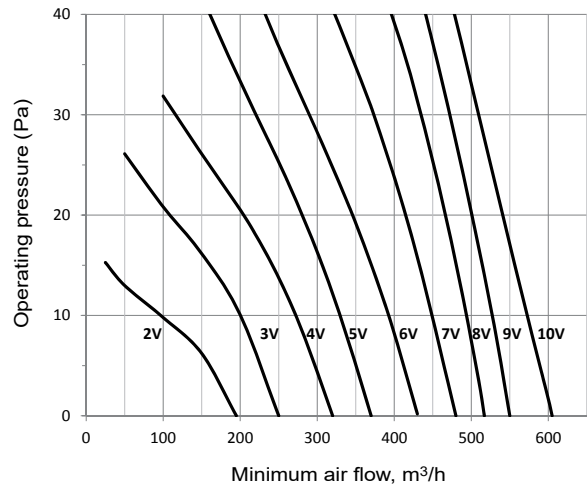

42NL 4-5 (with G3 filter)

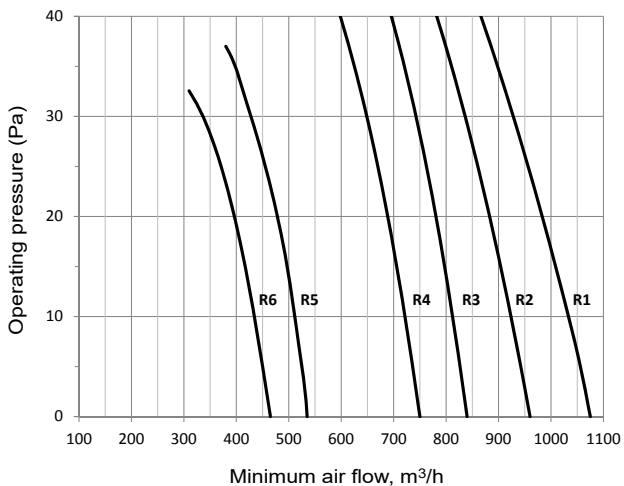

42NL 4-9 (with G3 filter)

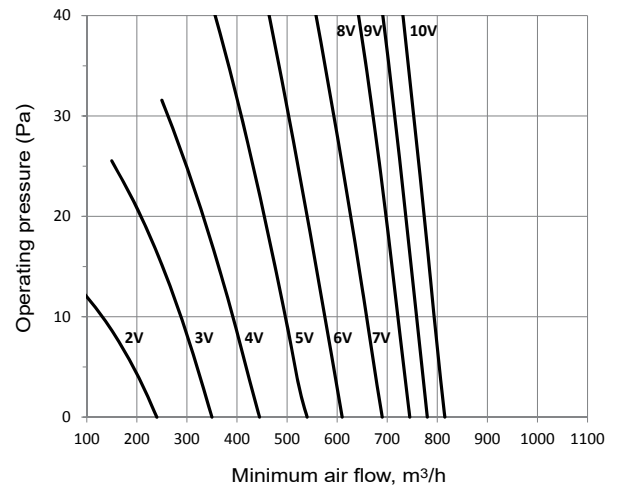

7 - 42NH AND 42NL PERFORMANCE DATA

42NL 5-5 (with G3 filter)

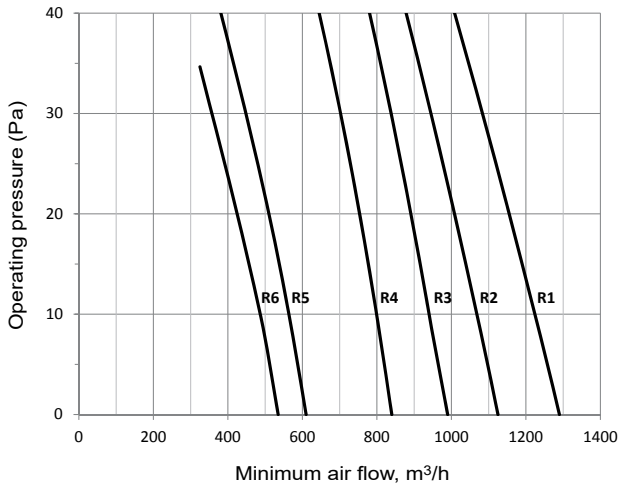

42NL 5-9 (with G3 filter)

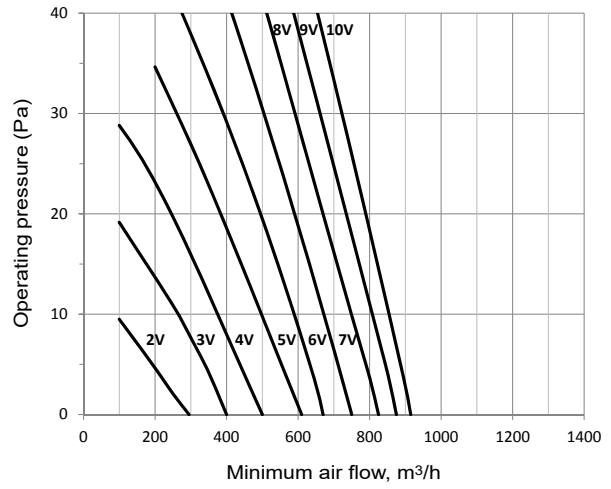

7.11.2 - 42NH Range

42NH 2-5 (with G3 filter)

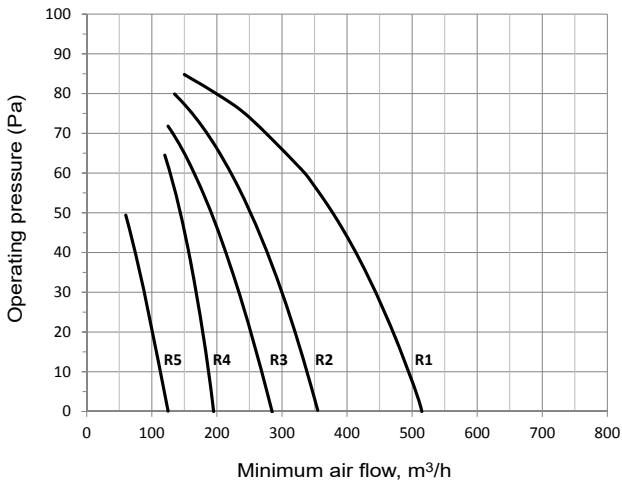

42NH 229 & 239 (with G3 filter)

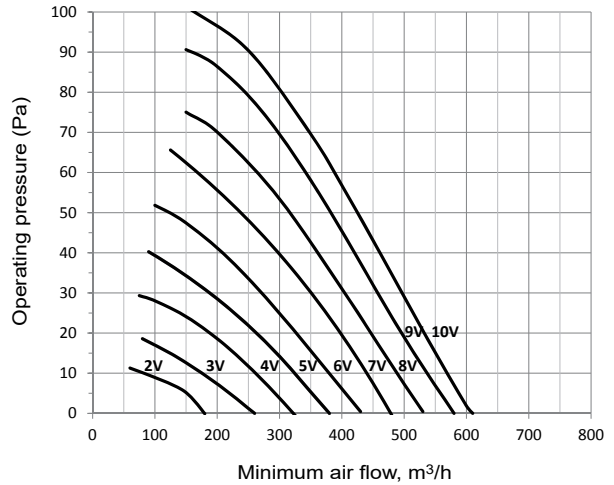

42NH 279 (with G3 filter)

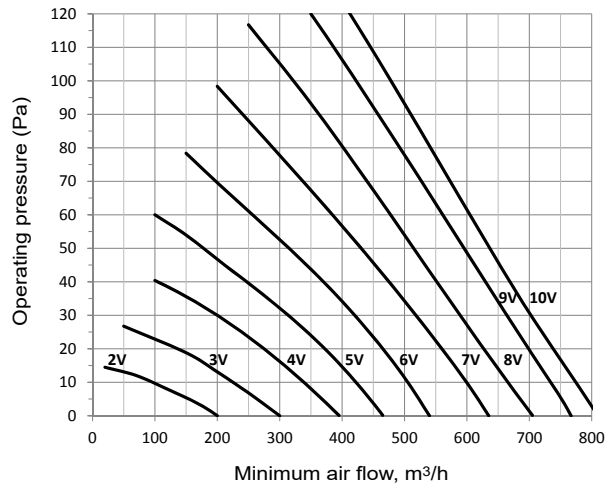

42NH 289 (with G3 filter)

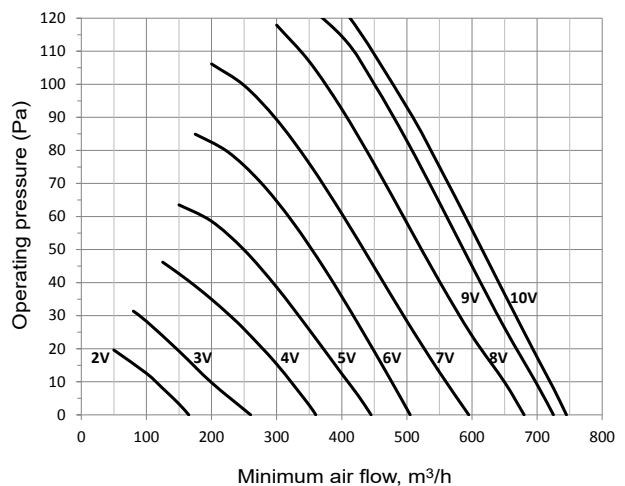

7 - 42NH AND 42NL PERFORMANCE DATA

42NH 3-5 (with G3 filter)

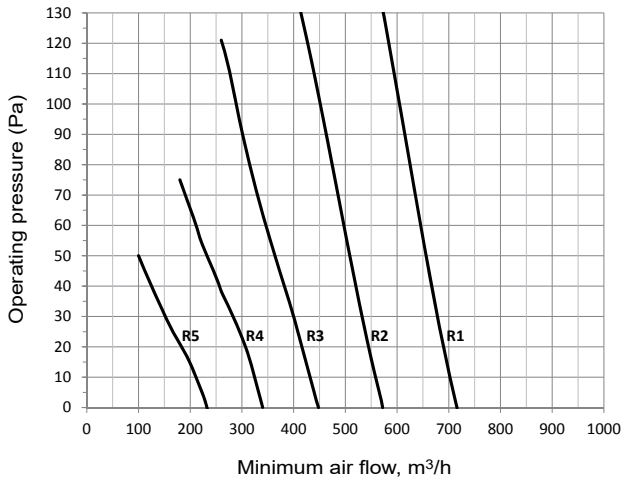

42NH 3-9 (with G3 filter)

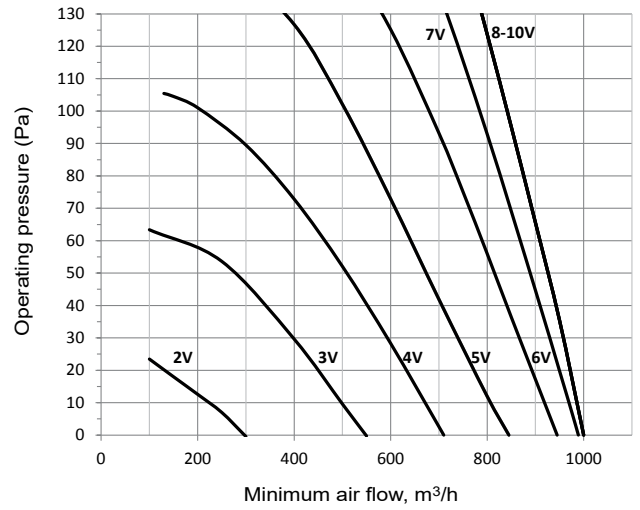

42NH 4-5 (with G3 filter)

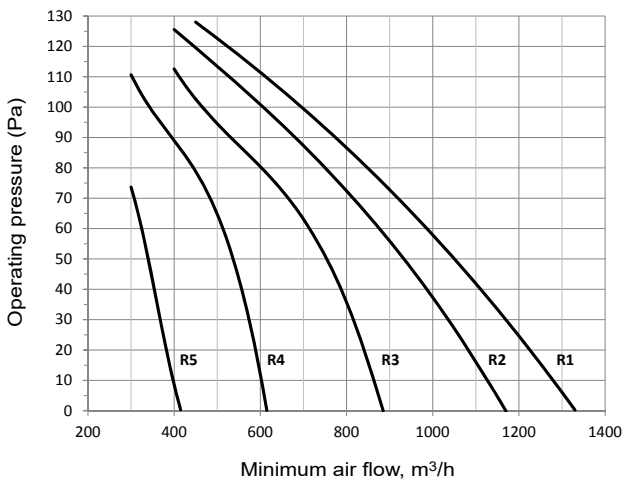

42NH 4-9 (with G3 filter)

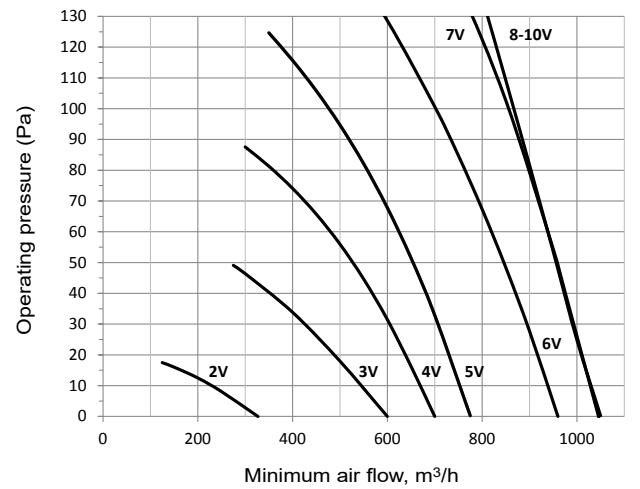

42NH 5-5 (with G3 filter)

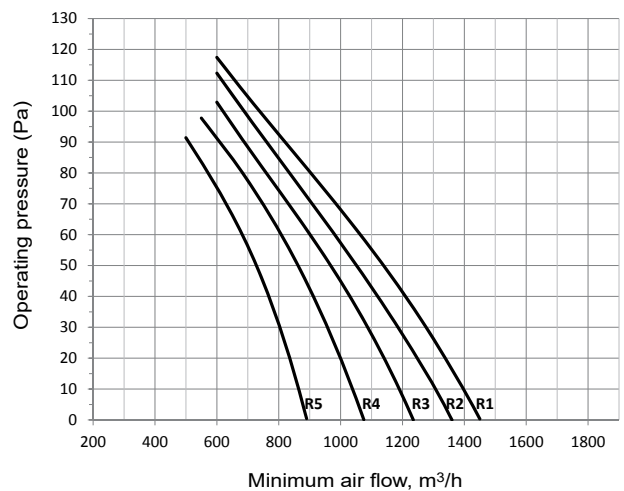

42NH 5-9 (with G3 filter)

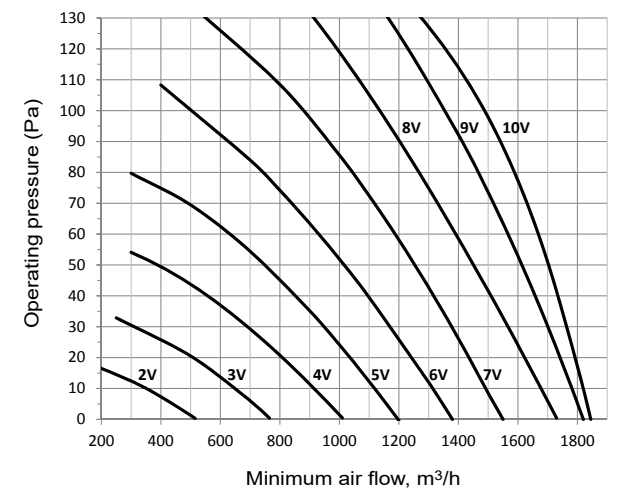

7 - 42NH AND 42NL PERFORMANCE DATA

42NH 6-5 (with G3 filter)

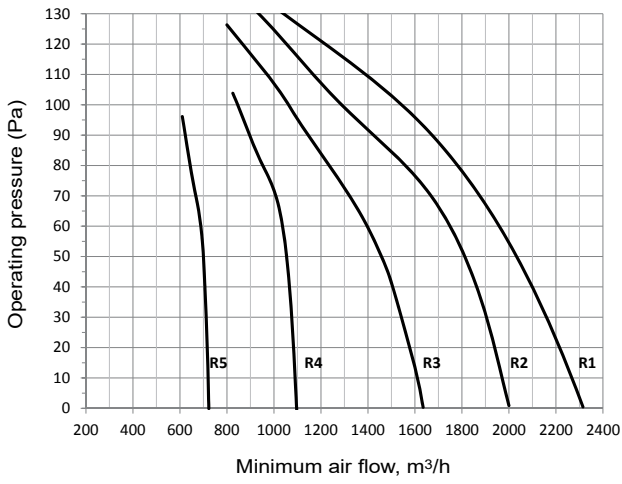

42NH 6-9 (with G3 filter)

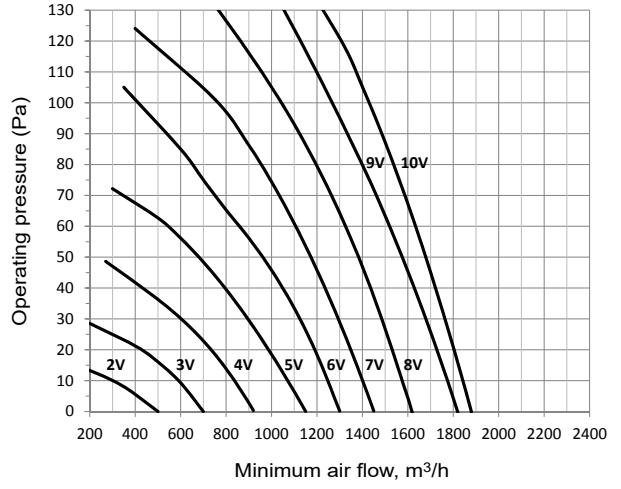

42NH 7-5 (with G3 filter)

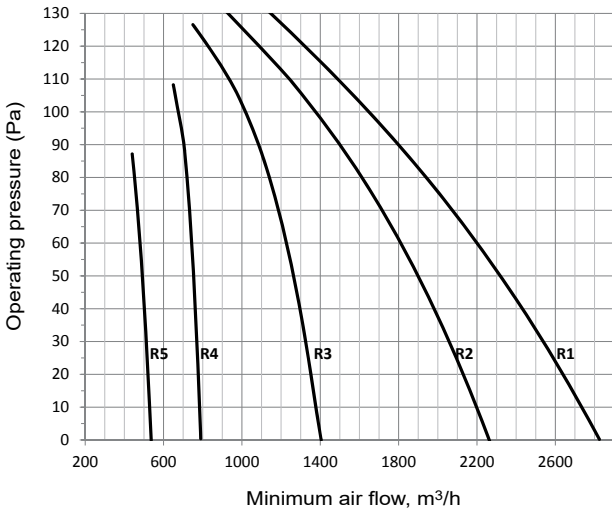

42NH 7-9 (with G3 filter)

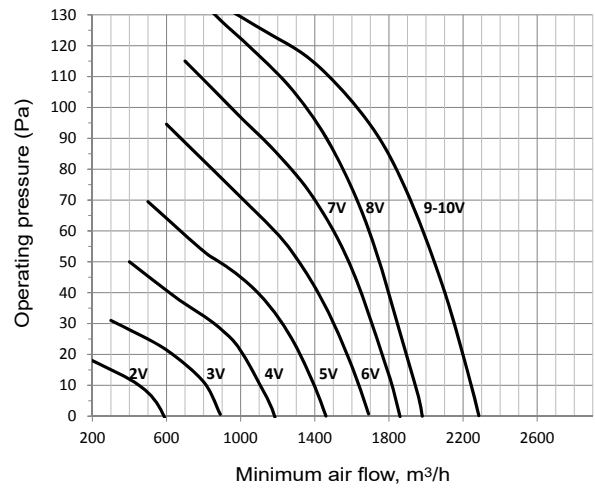

7 - 42NH AND 42NL PERFORMANCE DATA

Pressure drop (Pa) in the supply and return plenums as a function of the number of spigots

42NH & NL - Size 2

Air flow, l/s	28	56	83	97	111	125	139
Air flow, m ³ /h	100	200	300	350	400	450	500
Diameter 160 mm		Pressure drop (Pa)					
1 spigot	Return	3	6	10	13	16	20
	Supply	4	7	12	15	18	22
2 spigots	Return	1	3	4	5	7	8
	Supply	2	3	5	6	7	9
3 spigots	Return	1	1	2	2	3	3
	Supply	1	1	2	3	3	4
Diameter 200 mm		Pressure drop (Pa)					
1 spigot	Return	0	2	4	6	7	9
	Supply	3	5	8	10	12	15
2 spigots	Return	0	1	1	2	2	3
	Supply	1	1	2	2	3	4
3 spigots	Return	0	0	1	1	1	1
	Supply	0	0	1	1	1	2

42NH & NL - Size 3

Air flow, l/s	28	83	139	194	222	250	278
Air flow, m ³ /h	100	300	500	700	800	900	1000
Diameter 160 mm		Pressure drop (Pa)					
2 spigots	Return	1	3	6	9	11	13
	Supply	4	12	23	36	44	52
3 spigots	Return	1	2	4	7	8	10
	Supply	3	9	17	28	34	40
4 spigots	Return	0	1	2	4	4	5
	Supply	2	5	9	14	18	21
Diameter 200 mm		Pressure drop (Pa)					
1 spigot	Return	0	2	5	10	13	16
	Supply	1	5	15	30	39	49
2 spigots	Return	1	2	4	6	7	9
	Supply	3	8	15	24	29	35
3 spigots	Return	0	1	2	3	3	4
	Supply	1	3	7	10	13	15
4 spigots	Return	0	0	1	1	2	2
	Supply	1	2	4	6	7	8

42NH & NL - Size 4

Air flow, l/s	56	83	139	194	250	306	375
Air flow, m ³ /h	200	300	500	700	900	1100	1350
Diameter 160 mm		Pressure drop (Pa)					
3 spigots	Return	0	1	2	4	6	9
	Supply	1	2	6	11	17	26
4 spigots	Return	0	0	1	2	3	5
	Supply	1	1	3	6	10	15
5 spigots	Return	0	0	1	1	2	3
	Supply	0	1	2	4	6	9
Diameter 200 mm		Pressure drop (Pa)					
2 spigots	Return	0	1	2	3	5	8
	Supply	1	2	5	10	16	24
3 spigots	Return	0	0	1	1	2	4
	Supply	1	1	2	4	7	10
4 spigots	Return	0	0	0	1	1	2
	Supply	0	1	1	2	4	6

42NH & NL - Size 5

Air flow, l/s	56	139	208	278	347	417	486
Air flow, m ³ /h	200	500	750	1000	1250	1500	1750
Diameter 160 mm		Pressure drop (Pa)					
3 spigots	Return	2	7	11	16	21	27
	Supply	6	13	22	35	50	69
4 spigots	Return	1	3	5	8	12	16
	Supply	6	10	15	20	26	34
5 spigots	Return	1	2	4	7	9	12
	Supply	5	8	12	16	21	27
6 spigots	Return	1	2	3	4	6	8
	Supply	3	5	8	11	14	18
Diameter 200 mm		Pressure drop (Pa)					
2 spigots	Return	2	6	9	14	18	23
	Supply	5	11	19	30	45	62
3 spigots	Return	1	3	5	7	10	14
	Supply	5	9	13	18	23	30
4 spigots	Return	0	2	3	4	6	8
	Supply	3	5	7	10	13	17
5 spigots	Return	0	1	2	3	4	5
	Supply	2	3	4	6	8	10
6 spigots	Return	0	1	1	2	2	3
	Supply	1	2	3	4	6	7

42NH - Size 6

Air flow, l/s	83	167	278	361	444	556	639
Air flow, m ³ /h	300	600	1000	1300	1600	2000	2300
Diameter 200 mm		Pressure drop (Pa)					
3 spigots	Return	2	3	6	8	11	15
	Supply	3	7	12	16	20	26
4 spigots	Return	1	2	3	5	6	9
	Supply	2	4	6	9	11	14
5 spigots	Return	1	1	2	3	4	5
	Supply	1	2	4	5	7	9
Diameter 250 mm		Pressure drop (Pa)					
2 spigots	Return	2	3	6	8	10	14
	Supply	3	6	11	14	18	24
3 spigots	Return	1	1	2	3	4	6
	Supply	1	3	5	6	8	10
4 spigots	Return	0	1	1	2	2	3
	Supply	1	1	2	3	4	6

42NH - Size 7

Air flow, l/s	139	278	417	500	556	694	778
Air flow, m ³ /h	500	1000	1500	1800	2000	2500	2800
Diameter 200 mm		Pressure drop (Pa)					
4 spigots	Return	1	2	3	5	6	8
	Supply	1	5	12	18	22	35
5 spigots	Return	0	1	2	3	4	5
	Supply	1	3	8	11	14	22
6 spigots	Return	0	1	2	2	2	3
	Supply	1	2	5	8	10	15
Diameter 250 mm		Pressure drop (Pa)					
3 spigots	Return	1	1	3	3	4	6
	Supply	1	4	9	13	16	25
4 spigots	Return	0	1	1	2	2	3
	Supply	1	2	5	7	9	14
5 spigots	Return	0	0	1	1	1	2
	Supply	0	1	3	4	5	9

8 - OPERATING LIMITS

	Cooling mode	Heating mode
Water circuit	Min. inlet Temperature > 5°C	Max. inlet Temperature < 80°C
	< 40% ethylene / propylene glycol	< 40% ethylene / propylene glycol
	Water side pressure < 15.5 bar (1550 kPa)	Water side pressure < 15.5 bar (1550 kPa)
Ambient temperature and humidity	T < 27°C / 65% relative humidity	T < 40°C
	or Humidity weight < 14.7 g/kg dry air	
Supply air temperature	T > 12°C with maximum ambient humidity conditions (14.7 g/kg dry air)	T < 60°C with supply plenum and spigots application
		Recommendation to avoid stratification T < 35°C
EC Motor - Electrical input	Min: 216V	Min: 216V
	Max: 244 V	Max: 244 V
	60 or 50 Hz -1ph	60 or 50 Hz -1ph
AC motor - Electrical input	Min: 207V	Min: 207V
	Max: 253 V	Max: 253 V
	60 or 50 Hz -1ph	60 or 50 Hz -1ph
	(60Hz not available for 42NH325 & 335)	(60Hz not available for 42NH325 & 335)

NOTE: All performances data certified by Eurovent are based on 50Hz application.
Carrier doesn't ensure the same performances when the unit operates at 60 Hz; the RPM and power input of the fan-motor are usually higher.

9 - SPECIFICATION GUIDE 42NL/42NH

The Carrier 42NL/H is a new hydraulic ducted fan coil unit suitable for all applications and available in two versions:

- 42NL: low pressure mainly for hotel application
- 42NH: high pressure mainly for office application

This new range is available with 6 chassis sizes:

- Sizes 2/3/4/5: low height of 235 mm cooling capacity up to 6 kW
- Sizes 6/7: medium height of 285 mm cooling capacity from 5 to 12 kW

The 42NL/H_AC/LEC unit complies with the provisions of the following European directives:

- 2006/42/EC (Machinery),
- 2014/35/EU (LVD),
- 2014/30/EU (EMC),
- 2011/65/EU (RoHS),
- 2009/125/EC (Eco Design) & regulation 327/2011/UE,
- Regulation (EC) no. 1907/2006 (REACH),

And the corresponding UK legislation:

- Supply of Machinery (Safety) Regulations 2008,
- Electrical Equipment (Safety) Regulations 2016,
- Electromagnetic Compatibility Regulations 2016,
- The Restriction of the Use of Certain Hazardous Substances in Electrical and Electronic Equipment Regulations 2012,
- The Ecodesign for Energy-Related Products and Energy Information Regulations 2019, and following amendments,
- UK REACH Regulations 2019.

General description

The unit(s) must be designed, manufactured and tested in a facility with an ISO 9001 certified quality assurance system and an ISO 14001 certified environmental management system.

The unit(s) must be certified by Eurovent.

The unit(s) must be tested in operation at the factory before shipment

Technical specifications

Casing

- The 42NL/H is made of galvanized sheet metal with full high efficiency insulation to optimized the thermal and phonic performances of the unit .
- In order to comply with the various local regulations (fireclass) the 42NL/H unit is available with both class M1 type insulation (according to NF P 92-507) and Euroclass level B-s3-d0 (according to EN 13501).
- It is also equipped with antivibration-mounts as standard.

Fan-motor assembly

- The 42NL/H shall be equipped with centrifugal forward-curved , double inlet, simple, double or triple wheel fans with either:
 - Low Energy Consumption motor (LEC) EC motor that meet the new building energy performance objectives thanks to auto-adaptive air flow rate adjustment from 0 to 100% ensuring perfect cooling and heating conditions in the room.
 - Multi-speed asynchronous motor compliant with Erp2015 regulation, with internal overload protection.

Heating or cooling coil

- 42NL/42NH units shall be equipped with either a cooling/heating changeover coil, a monobloc heating and cooling coil or a cooling coil and an electric heater. The water coils shall be provided with manual air purge valves
- The cooling and heating coils shall be made from copper tubes and aluminum fins. The maximum water side working pressure shall not exceed 15.5 bar (1550 kPa).

Filter

- The 42NL/H shall at least be provided with filter G3 class according to EN 779.
- Other filtration available: pleated filter M5 class according to EN779.

Controller range

- A-B-C-D type electronic thermostats for all applications
 - Type A: 2 pipes with AC motor
 - Type B: 4 pipes or 2 pipes with electric heaters and AC motor
 - Type C: 2 pipes with EC motor
 - Type D: 4 pipes or 2 pipes with electric heaters and EC motor
- NTC controller
 - Communication PID controller compatible with Aquasmart Evolution System package (proprietary CCN protocol)
 - Manages the motorised louvres of the grille in manual or automatic mode
 - Manages the EC motor to optimise comfort
 - Manages a CO₂ sensor to improve air quality
- WTC controller
 - BACnet or LON open communication protocol
 - Communication PID controller
 - Large range of user interfaces, wall mounted or remote
 - Manages the motorised louvres of the grille in manual or automatic mode
 - Manages the EC motor to optimise comfort
 - Manages a CO₂ sensor to improve air quality
 - Optional light and/or blinds management modules from the same user interface
 - Large range of sensors (light, presence, etc.)

Valve options

- Control Two or four-ways bodies with 230V power supply:
 - On/Off 230V actuator
 - Floating 3-point 230 V actuator
- Control and balancing Two-way valves. Two-in-one designed valves enabling both the setting of the nominal waterflow in the fan-coil and the waterflow control with the NTC or the WTC, with 230 V power supply:
 - On/Off 230V actuator
 - Floating 3-point 230V actuator

The quality management system of this product's assembly site has been certified in accordance with the requirements of the ISO 9001 standard (latest current version) after an assessment conducted by an authorized independent third party.

The environmental management system of this product's assembly site has been certified in accordance with the requirements of the ISO 14001 standard (latest current version) after an assessment conducted by an authorized independent third party.

The occupational health and safety management system of this product's assembly site has been certified in accordance with the requirements of the ISO 45001 standard (latest current version) after an assessment conducted by an authorized independent third party.

Please contact your sales representative for more information.

Order No.: 10008, 12.2022. Supersedes order No.: 10008, 02.2021.

Carrier S.C.S, Rte de Thil - 01120 Montluel, France.

Manufacturer reserves the right to change any product specifications without notice.

The illustrations in this document are for illustrative purposes only and not part of any offer for sale or contract. The manufacturer reserves the right to change the design at any time without notice.