



PRODUCT SELECTION DATA

DUCTABLE FAN COIL UNIT



Ductable unit for suspended ceiling or raised floor

Extra flat unit for better integration in renovation or new build projects

Optimised energy consumption level

Flexible configuration to meet the different requirements of buildings

Managed comfort

42EP



The Carrier 42EP range is available in 3 casing sizes with a 2-pipe coil, 2-pipe coil plus electric heater or 4-pipe coil. The total cooling capacity range is from 0.4 to 4.2 kW and the heating capacity range is 0.5 to 5 kW in the 2-pipe configuration and 0.5 to 4.8 kW with 4 pipes (Eurovent conditions)



CARRIER participates in the ECP programme for FC/FCP
Check ongoing validity of certificate:
www.eurovent-certification.com

1 - FUNCTIONS AND CONFIGURATIONS

- New generation slimline ductable fan coil (150 mm high) which can be adapted to both the new build and renovation markets to gain height underneath the suspended ceiling and improve the well-being of occupants.
- Equipped with an innovative fan combined with a low energy consumption (LEC) electronically commutated motor that meets the new building energy performance objectives thanks to auto-adaptive adjustment of the air flow rate from 0 to 100% ensuring perfect cooling and heating conditions in the room.
- G3 filter as standard.
- Safe factory installed electric heater with a wide choice of output levels.
- Low water pressure drop with factory installed valves.
- Factory-fitted options (valves and controllers) for fast and easy installation in suspended ceilings.
- The 42EP is available for fitting either in a suspended ceiling or a raised floor
- High operating pressure (above 150 Pa) with managed flow rate losses

1.1 - Configuration and flexibility

Each size of the 42EP can be supplied:

- with free return and/or direct air supply
- with a rectangular sleeve on the return and/or on the supply air
- with return plenums and/or supply air plenums to meet the requirements of installations with spigots with a diameter of 125 mm.

The illustration below shows the available plenum configurations with spigots with a diameter of 125 mm.

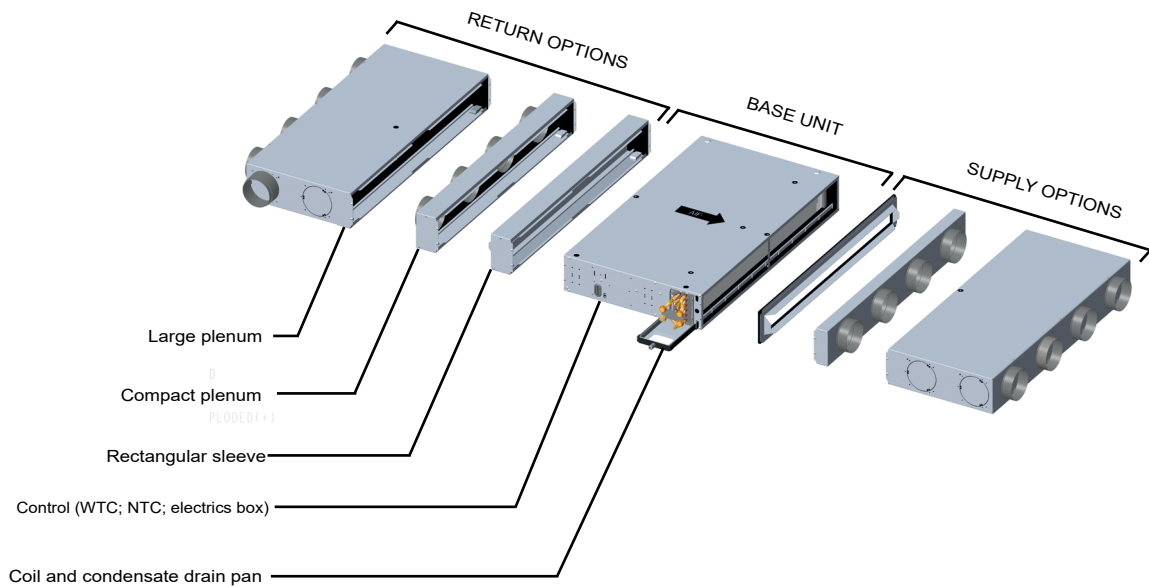

1 - FUNCTIONS AND CONFIGURATIONS

1.2 - Configuration with plenum with linear arrangement

Option of a Compact or Large plenum with spigots with a diameter of 125 mm
 (*) = Minimum number of spigots required to ensure sufficient available static pressure and fan reliability.

Ø125 mm	Number of spigots		
	42EP0xx	42EP1xx	42EP2xx
	2	3	4

Large plenum with or without fresh air on the return

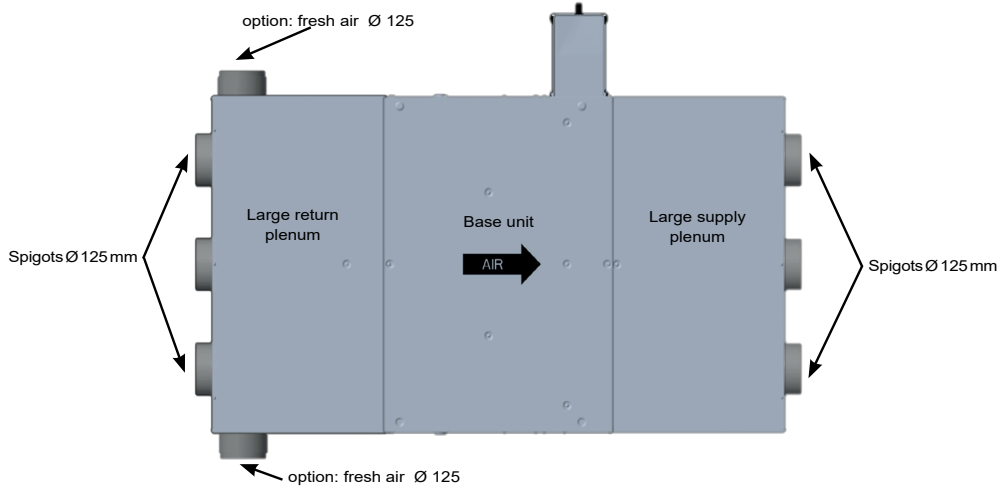

Large plenum with or without fresh air on the supply air

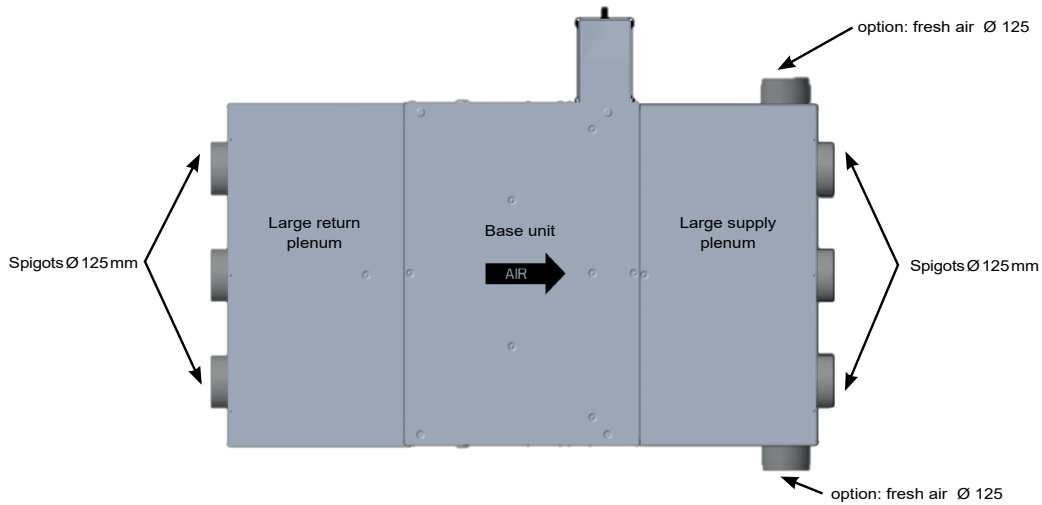

Compact plenum (fresh air not available)

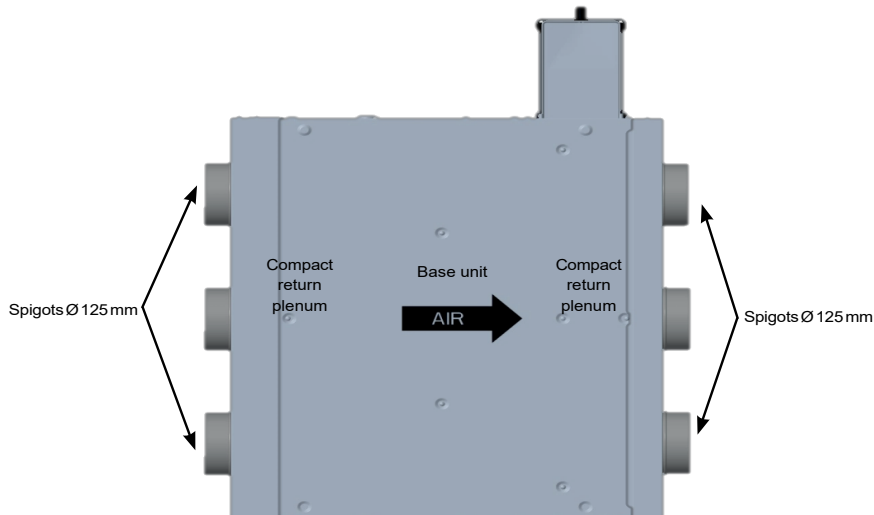

1 - FUNCTIONS AND CONFIGURATIONS

1.3 - Configurations with lateral plenum (U-shaped)

Ø125 mm	Number of spigots		
	42EP0xx	42EP1xx	42EP2xx
	2	2	2

Large plenum with or without fresh air on the return

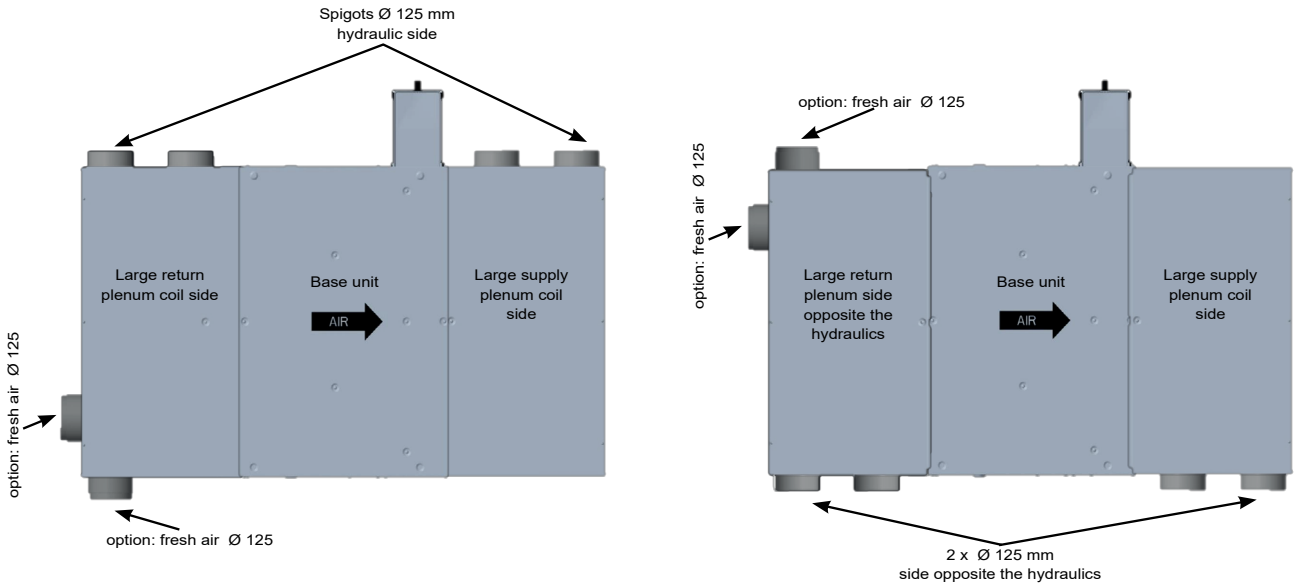

Large plenum with or without fresh air on the supply air (Fresh air pressure available on the supply air must be greater than 200 Pa)

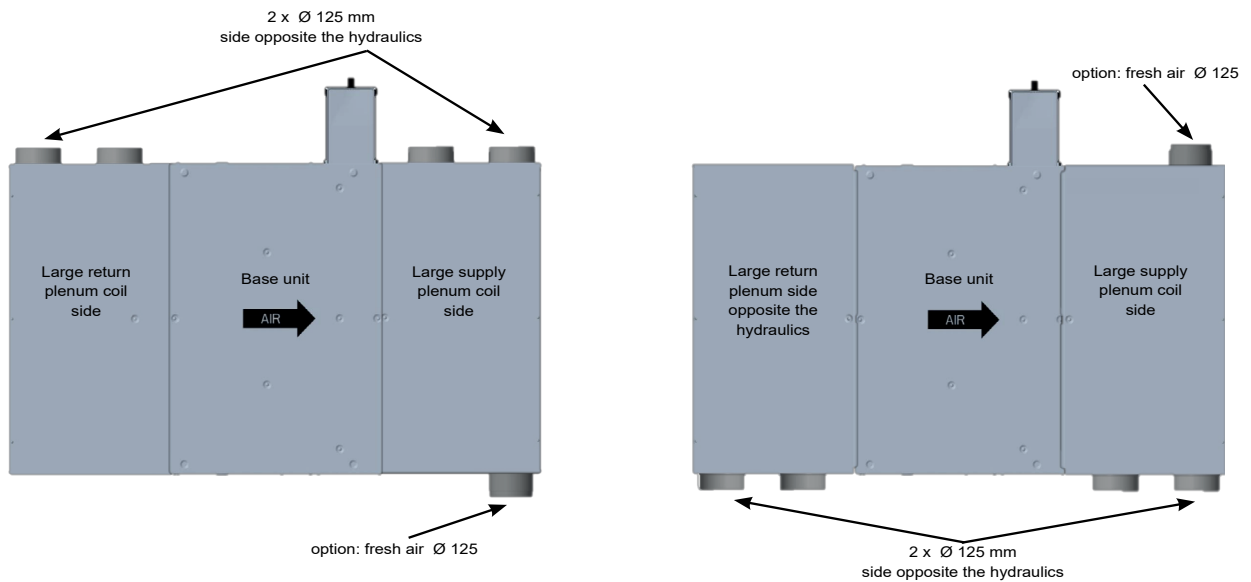

2 - DIMENSIONAL DRAWINGS

NOTE: All the plans shown are set up with the coil on the right; units set up with the coil on the left are strict symmetrical. The unit is shown in a suspended ceiling; it is available in a raised floor depending on the configuration (see type key on page 16)

Standard unit with return and supply without rectangular sleeves fitted

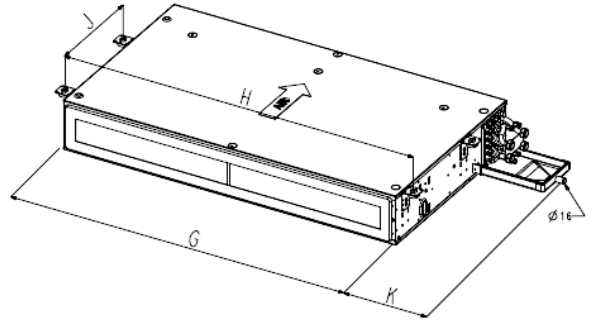
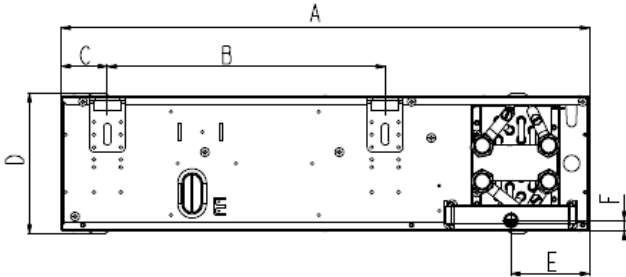

Dimensions in mm			
Size	0xx	1xx	2xx
A	589	589	589
B	310	310	310
C	51	51	51
D	156	156	156
E	87	87	87
F	15	15	15

Dimensions in mm			
Size	2xx	3xx	4xx
G	520	820	1020
H	569	869	1069
J	310	310	310
K	329	228	228
G + K	849	1048	1248
Weight* [kg]	12	16	21

Standard unit with rectangular sleeves on the return and supply

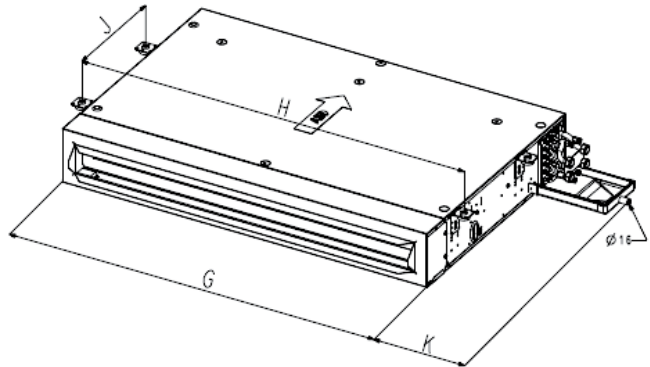
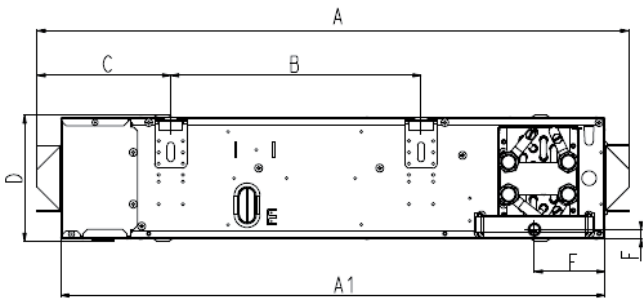

Dimensions in mm			
Size	0xx	1xx	2xx
A	733	733	733
B	310	310	310
C	165	165	165
D	156	156	156
E	87	87	87
F	15	15	15
Sleeves	451 x 81	751 x 81	951 x 81

Dimensions in mm			
Size	0xx	1xx	2xx
A1	674	674	674
G	520	820	1020
H	569	869	1069
J	310	310	310
K	329	228	228
G + K	849	1048	1248
Weight* [kg]	13	18	25

KEY

* Maximum weight - without option - without water
 Air flow direction

2 - DIMENSIONAL DRAWINGS

Standard unit with compact plenum with linear arrangement on the return and supply air (optimised length)

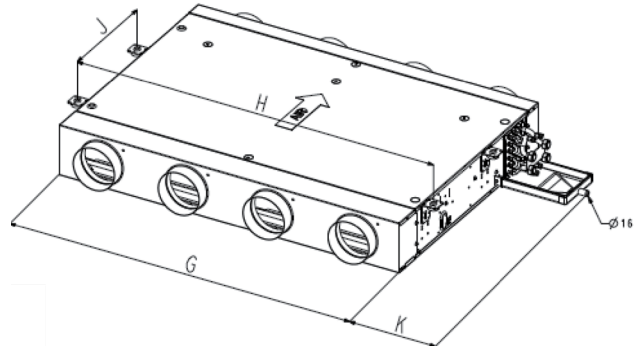
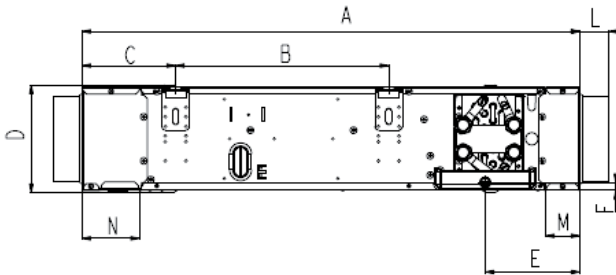

Dimensions in mm			
Size	0xx	1xx	2xx
A	724	724	724
B	310	310	310
C	136	136	136
D	156	156	156
E	138	138	138
F	15	15	15
M	50	50	50
N	83	83	83
L	42	42	42

Dimensions in mm			
Size	0xx	1xx	2xx
G	520	820	1020
H	569	869	1069
J	310	310	310
K	329	228	228
G + K	849	1048	1248
Weight* [kg]	15	21	28

Standard unit with large plenum with linear arrangement on the return and supply air

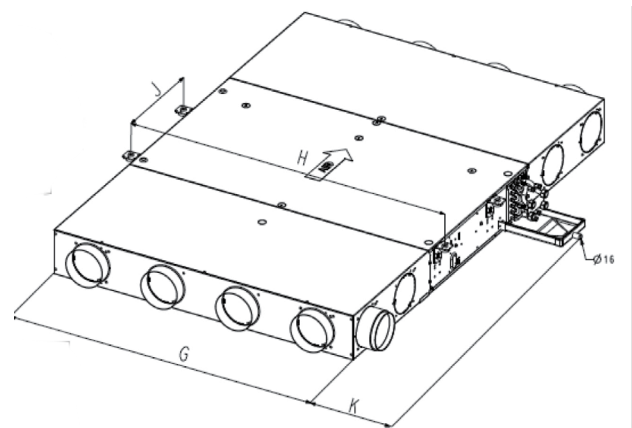
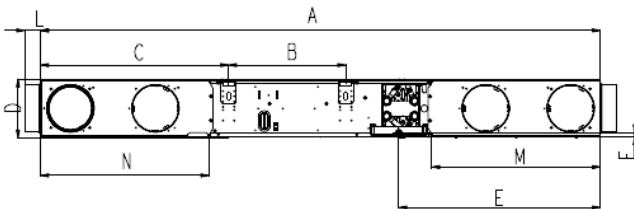

Dimensions in mm			
Size	0xx	1xx	2xx
A	1482	1482	1482
B	310	310	310
C	498	498	498
D	156	156	156
E	534	534	534
F	15	15	15
M	446	446	446
N	446	446	446
L	62	62	62

Dimensions in mm			
Size	0xx	1xx	2xx
G	520	820	1020
H	569	869	1069
J	310	310	310
K	329	228	228
G + K	849	1048	1248
Weight* [kg]	24	33	42

KEY

* Maximum weight - without option - without water



Air flow direction

2 - DIMENSIONAL DRAWINGS

Water coil

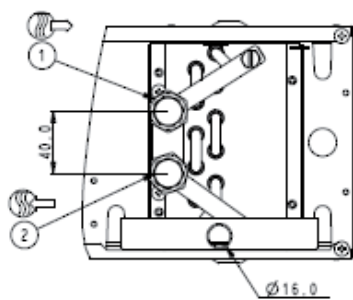

2-pipe air coil type 029 or 129 or 229

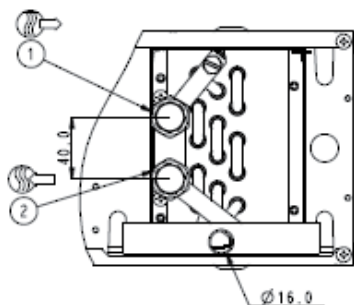

2-pipe air coil type 039 or 139 or 239

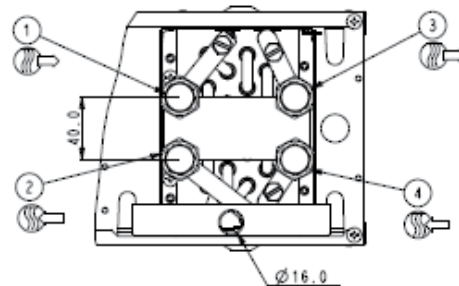

4-pipe air coil type 049 or 149 or 249

- 1 Cooling water outlet for 4-pipe coil and heating or cooling for 2-pipe coil
- 2 Cold water inlet for 4-pipe coil and hot or cold for 2-pipe coil
- 3 Heating water outlet for 4-pipe coil
- 4 Heating water inlet for 4-pipe coil

3 - MAIN MODULES AND COMPONENTS

3.1 - Casing

In order to further enhance occupant comfort, this product range offers especially low noise levels. The casing is made of galvanised sheet steel with full high-efficiency internal lining for optimised thermal and sound insulation of the unit.

In order to comply with the various local regulations (fire class) the fan-coil unit is available with both class M1 type insulation (according to NF P 92-507) and Euroclass level B-s3-d0 (according to EN 13501). It is also equipped with anti-vibration mounts as standard.

In order to reduce the dimensions to the minimum, the units are equipped with high-efficiency heat exchangers with very high cooling capacity/treated air flow ratios. The condensate drain pan height is optimised.

3.2 - Fan motor assemblies.

3.2.1 - Low-consumption fan motor (variable-speed LEC motor)

Motor description

- Permanent magnet brushless motor
- Electronically commutated
- Class B winding insulation, varnish class F
- See operating limits in section 8

42EP units are equipped with LEC fan motors, controlled by a 0-10 V signal, which can be actuated by Carrier NTC or WTC controllers.

NOTE: In this case, the minimum control signal that allows the motor to start is 2 V for the two- and four-pipe versions; for versions equipped with electric heaters, please refer to section 9.

If the product is supplied without a Carrier control device, verification of EMC conformity is the responsibility of the installer.

3.3 - Fan wiring solutions

3.3.1 - Unit with bare wires (standard)

The motor cable is left for the customer to connect up using its own resources.

The variable-speed low energy consumption (LEC) motor must be actuated by a 0-10 VDC signal.

3.3.2 - Variable-speed low energy consumption (LEC) fan motor with electrics box

This option allows the installer to connect the unit directly to the electrical terminal strip installed in the electrics box. The electrics box can be opened with a screwdriver.

The 0-10 VDC signal that controls the variable-speed fan is directly accessible at the terminal strip.

3.3.3 - Fuse holder or circuit breaker option

A fuse holder or a circuit breaker can be fitted to the units as an option.

3.4 - Hydraulic coil

- Aluminium fins mechanically bonded by expansion onto copper pipes
- 1/2-inch threaded female water inlet and outlet couplings
- Air bleed valves and drain valves as standard.
- Operating pressure 1600 kPa.

The coil, condensate drain pan and coil access door form a drawer which is easy to remove.

3.5 - Single unit condensate drain pan

As standard, the unit is equipped with a single unit condensate drain pan made from polypropylene and insulated with 5 mm of foam.

Drain connection diameter: Ø 16 mm external

HB fire rating (as per standard UL94).

As an option, the unit can be equipped with an aluminium pan insulated with 5 mm of foam.

This pan is compulsory if an electric heater is to be used

3.6 - Filter

3.6.1 - Specifications

42EP units include a non-regenerative G3 filter as standard in compliance with EN 779.

The "without filter" option is only available for units with a plenum or a rectangular sleeve on the return side to ensure that a duct can be connected when the unit is operating.

To prevent fouling of the coil, Carrier recommends the use of a filter installed either in the fan coil unit or in the return air grille.

4 - OPTIONS SPECIFICATIONS

4.1 - Electric heater (option for 2-pipe coil)

Resistive wire type heater

- Supply voltage: 230 V - 1 ph - 50 Hz
- Heater size and capacity per unit (+5% ; -10%):

Electric heater capacity	Low	Medium	High	Very High
42EP 0x9	1 x 500 W	1 x 800 W	NA	NA
42EP 1x9	1 x 500 W	1 x 800 W	1 x 1000 W	NA
42EP 2x9	1 x 500 W	1 x 800 W	1 x 1000 W	1 x 1600 W

- The heater is protected with a dual safety device:
 - a) Self-holding automatically reset integrated safety thermostat
 - b) Destructive thermofuse link
- Available for 2-pipe coil only.

WARNING: A minimum supply air flow rate must be maintained to avoid damaging the electric heaters.

A minimum control signal of 3 V is selected by default with the Carrier electronic controller (NTC / WTC).

4.2 - Fresh air controller (option)

4.2.1 - Constant volume fresh air controller

The coil can be fitted with a constant fresh air flow controller adjustable from 15 m³/h to 180 m³/h to allow the fresh air intake and the air change rate to be controlled.

The fresh air supply may be located in the supply plenum, or in the return plenum.

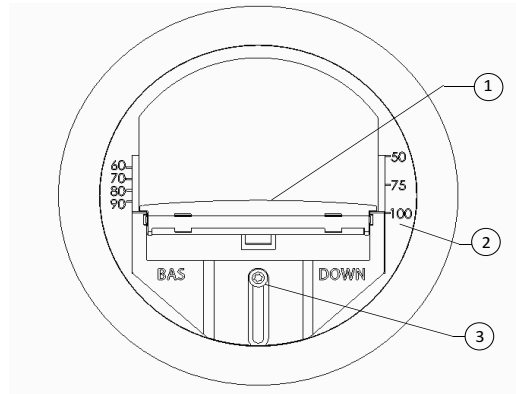

Example: Range 50-100 m³/h

- 1 Air Damper
- 2 Fresh airflow damper position setting (in m³/h)
- 3 Airflow adjustment screw

The fresh air controller may be modified on site by relocating the damper (adjustable screw). Three ranges of air-controller are provided: 15 to 50m³/h, 60 to 100m³/h and 110 to 180m³/h.

IMPORTANT: If an optional return air temperature sensor is provided, the constant fresh air flow rate must not exceed 50 % of the unit supply air flow rate at minimum speed.

NOTE: To operate correctly, the fresh air flow controller requires a differential pressure in the range of 60 Pa to 210 Pa.

4.2.2 - Variable volume fresh air controller

The unit can be equipped with an optional variable fresh air flow controller from 0-55 l/s (0-200 m³/h). It is connected to the numeric Carrier controller and can regulate the fresh air intake in two ways:

- Either using a fixed rate set by the installer that can be reconfigured as required
- Or based on the CO₂ level; in this case it is connected to a CO₂ sensor via the Carrier numeric controller.



NOTE: with the variable fresh air flow controller, the pressure upstream of the fresh air duct must be 180 Pa. The fresh air flow controller is not supplied fitted.

4 - OPTIONS SPECIFICATIONS

4.3 - Valves and actuators

NOTE: The motor/valve assembly is normally closed.

4.3.1 - Valve actuators

A wide choice of actuators is available with two- or four-way valve bodies (three-way with integral bypass) to offer the right solution for any controller type and customer requirement, from on/off to proportional types, with either 230 V or 24 V power supply:

- On/off 230 V actuator
- On/off 24 V actuator
- Floating 3-point 230 V actuator
- Floating 3-point 24 V actuator
- Modulating 0-10 V/24 V actuator

When combined with LEC motors and WTC or NTC controllers, floating 3-point 230 V actuators are recommended to increase energy savings and enhance comfort.

NOTE: 24 V power supply actuators are not compatible with Carrier controllers (Thermostats A/B/C/D, WTC and NTC).

4.3.2 - Standard two-way valve body and three-way valve body (with integral bypass)

Specifications of 1/2" two-way and three-way valves

- 1/2" male BSP connection for union nuts
- Straight valve body with arrow indicating direction of flow embossed on valve body
- Nominal size DN15 for 1/2" valve
- Nominal pressure: PN 16 bar

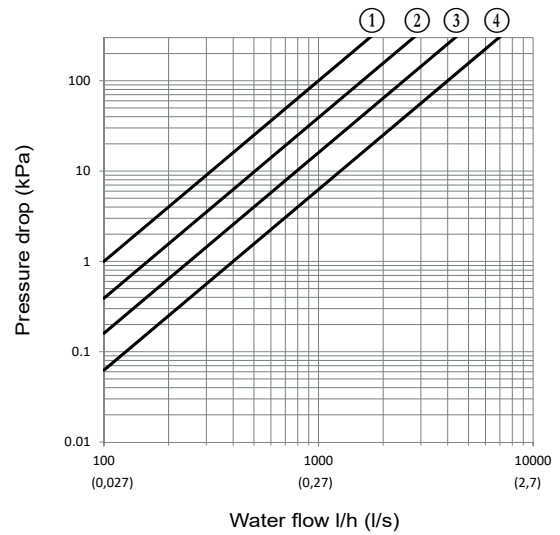
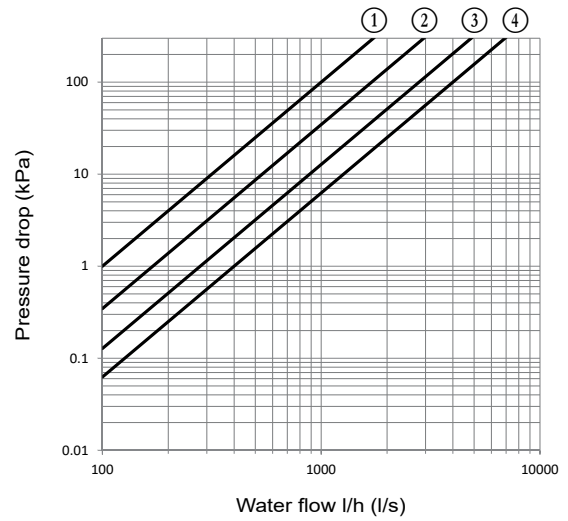

4 - OPTIONS SPECIFICATIONS

4.3.3 - Two way balancing valve body

Two-way valves with embedded balancing technology are available as an option. The CARRIER automatic balancing two-way valve combines the functionality of a dynamic balancing valve and a control valve in one product.



The dynamic balancing function maintains a constant differential pressure over the control valve.

The control valve regulates the flow by means of a variable orifice which is controlled by the actuator.

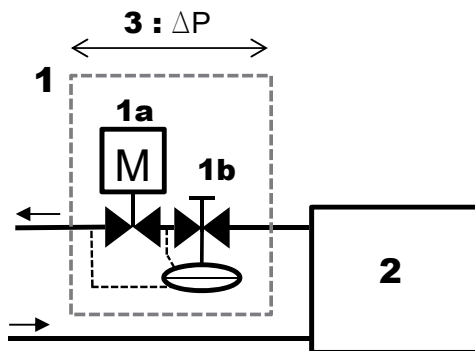

Key

1. Two-way valve with balancing function
 - 1a. Valve actuator for waterflow control
 - 1b. Differential pressure controller & balancing feature
2. Fan-coil unit
3. Minimum operating pressure drop at nominal waterflow:
20 kPa for sizes 4 and 5

The constant differential pressure across the control valve ensures accurate control and maximises valve authority, independently of the pressure conditions inside the system.

Advantages compared to the two-way valve

- Improved and reliable commissioning. The water flow can be set and controlled on site.
- Higher energy efficiency due to optimal waterflow and maximized valve authority.
- Enhanced comfort thanks to stable and precise ambient temperature control.

Specifications for automatic balancing 2-way valves

- 1" male BSP connection for union nuts
- Straight valve body with arrow indicating direction of flow embossed on valve body
- Nominal size DN 20 for 1" valve
- Nominal pressure: PN 16 bar
- Minimum operating differential pressure = 20 kPa at nominal flow.

4.4 - Water hoses (option)

4.4.1 - Materials

- Pipes: EPDM-based elastomer (Ethylene Propylene Diene Monomer)
- Braid: 304L stainless steel
- Insulation: cellular foam rubber with M1 fire rating (9 mm thick, flexible water pipes).

4.4.2 - Specifications

- Minimum bend radius (insulated pipes): 106 mm
- The water hoses are designed for treated or untreated water.
- Maximum operating pressure: 16 bar
- 1/2" female gas couplings with flat gaskets
- Length: 1 m.

4 - OPTIONS SPECIFICATIONS

4.5 - Sensors (option)

4.5.1 - Water temperature sensor

A water temperature sensor can be provided as an option for NTC and WTC controllers.

- For 2-pipe coil: The sensor is installed on a cooling/heating water pipe (for change-over function).
- For 4-pipe coil: The sensor is installed on a heating water pipe (for cold-draft function that prevents the operation of the unit when the heating network is off).

While the fan coil unit is delivered with an electricals box, the "water temperature sensor" option is actually a switch that will be connected to the Carrier thermostat.

NOTE:

- *The water sensor option (switch) with electrical box is only available for 2-pipe coil without electric heater.*
- *A water probe can also be provided as an accessory only in order to use the cold draft function of the thermostat.*

4.5.2 - Air temperature sensors

Two factory-fitted air temperature sensors are available as an option for NTC and WTC controllers. They measure the temperature at the supply and/or return side.

4.6 - Condensate pump (option)

The condensate pump option is designed to fit on the side of the unit drain pan. Electrical power supply 230V-50/60Hz.

Condensate pump discharge performances:

Discharge head	Water flow rate in litres per hour (-15% / +20%)			
	Horizontal length of the discharge pipe			
	5 metres	10 metres	20 metres	30 metres
1 metre	10,4	9,1	8,3	7,3
2 metres	8,8	7,8	7	6,4
3 metres	7,9	7,1	6,3	5,8
4 metres	7	6	5,3	4,9

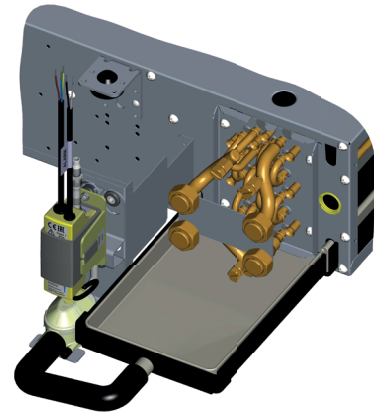

Technical characteristics	
Max. flow rate	10,4 l/h
Max. discharge height	7 m (flow rate 4 l/h)
Maximum pressure	10 m (flow rate 0 l/h)
Sound level at 1 m as per EN ISO 3744 and 4871 (Measurement taken at LNE, pump in water, outside of application)	20,2 dBA
Electrical supply	230V +10%/-15% - 50/60Hz – 19W
Electrical insulation class	Class 1
Detection levels	ON: 14,7 mm, OFF: 10,7 mm, AL: 17 mm
Safety switch	BS: 5A resistive – 250V Contacts made from AgNI 90/10, gold-plated
Heat protection (overheating)	70°C (automatic restart)
Operating cycle (duty factor)	100%
Protection (as per BS EN 60529)	IP64
Safety standard	CE
RoHS directive	Compliant
WEEE directive	Compliant

5 - CONTROL

The unit can be supplied with a wide range of Carrier controls. These offer functions to suit the various application requirements, summarised in the table below.

	Thermostats	NTC	WTC
Communication Protocols			
Carrier Communication Network (CCN) Aquasmart compatible		x	
BACnet MSTP			x
LON			x
Control algorithms			
On-off	x		
Proportional-integral		x	x
Carrier Energy saving algorithm		x	x
Fan control			
AC motors 3 speeds descreet	Type A&B	x	x
Automatic optimum fan speed selection	x	x	x
EC motors 3 speeds descreet	Type C&D	x	x
EC motors Variable speed		x	x
Water Valve management			
Air flow control only (no water valve)	x		
230V On-off actuators	x	x	x
230V Modulating actuators (floating 3pts)		x	x
Main functions			
Setpoint control	x	x	x
Occupied/unoccupied mode	x	x	x
Frost protection mode	x	x	x
Window / Door contact input	x	x	x
Measurement of water inlet temperature for automatic seasonal changeover (2 pipes)	Type A&C	x	x
Measurement of water inlet temperature to prevent cold-draft (4 pipes and 2 pipes + electric heater)	Type B&D	x	x
Manual changeover	x	x	x
Frost protection mode	x	x	x
Continuous ventilation within dead-band	x	x	x
Periodical ventilation within dead-band	x	x	x
On-site configuration	x	x	x
Unit grouping Master/Slave	x	x	x
Cassette Louvers control		x	x
Supply air temperature monitoring limiting		x	x
Electric heater loadshed		x	x
Dirty filter alarm		x	x
Alarm reporting		x	x
Indoor Air Quality control (CO ₂ sensor)		o	o
Demand control ventilation (DCV) (0-10V fresh air valve)		o	o
Free cooling mode			o
Presence detection			o
User interfaces			
Automatic or manual fan speed control	x	x	x
Setpoint adjustment	x	x	x
Occupancy (eco) button	x	x	o
Digital display		o	o
CO ₂ sensor		o	o
Control kit			
On site control kit solution			o

Key

X Feature available as standard

O Optional

NOTE: for the features and specifications of the Carrier controllers outlined above, refer to the technical documentation for each controller. Upon special request, other controller types can be factory-installed on the units (supplied by Carrier or the customer).

6 - LIST OF PRODUCT SPECIFICATIONS

Feature name	Digit no. type key	Value	Description	Compatibility
Range	1-2	42		
	3-4	EP		
Chassis size	5	0	Chassis size 0	
		1	Chassis size 1	
		2	Chassis size 2	
Coil efficiency	6	2	Standard	in 2-pipe only
		3	Medium	in 2-pipe only
		4	Medium	in 4-pipe only
Motor type	7	9	LEC low consumption motor	
Connection and coil type	8	F	2-pipe coil left-hand	connection: in the air flow direction
		G	2-pipe coil right-hand	
		C	4-pipe coil left-hand	
		D	4-pipe coil right-hand	
Control	9	-	Bare wires	
		E	Electrics box	
		K	NTC	
		L	WTC LON	
		M	WTC BACNET	
Valve body	10	-	Without valve	
		G	2-way valve	
		H	3-way valve with by-pass	
		L	Automatic balancing 2-way valve without pressure tappings	changeover sensor not compatible with two-way valve and automatic balancing 2-way valve
		T	Automatic balancing 2-way valve with pressure tappings	
Electric heater	11	-	Without electric heater	
		E	500 W electric heater	
		F	800 W electric heater	
		G	1000 W electric heater	Not available in Size 0
		H	1600 W electric heater	Not available in Size 0 & 1
Valve actuator	12	-	Without actuator	
		A	230 V ON/OFF actuator	
		C	3-point 230 V actuator	
		B	24 V ON/OFF actuator	not available with CARRIER control
		D	3-point 24 V actuator	not available with CARRIER control
		E	Modulating 0-10 V/24 V actuator	not available with CARRIER control
		P	Modulating PWM 230 V actuator	only for electrics box or WTC
Return plenum	13	-	Without	
		A	Rectangular sleeve	
		B	Compact plenum	number of spigots according to size see sect.1.2
		C	Large plenum (linear arrangement)	
		D	Large plenum (lateral arrangement) hydraulic side	
		E	Large plenum (lateral arrangement) opposite the hydraulics	
Supply plenum	14	-	Without	
		A	Rectangular sleeve	
		B	Compact plenum	number of spigots according to size see sect.1.2
		C	Large plenum (linear arrangement)	
		D	Large plenum (lateral arrangement) hydraulic side	
		E	Large plenum (lateral arrangement) opposite the hydraulics	
Spigot diameter on the return	15	-	Without	
		A	Ø 125 mm	
Spigot diameter on the supply air	16	-	Without	
		A	Ø 125 mm	

Key:

Basic configuration

6 - LIST OF PRODUCT SPECIFICATIONS

Feature name	Digit no. type key	Value	Description	Compatibility
Filtration	17	-	Without	compulsory plenum or sleeve on the return
		V	G3	
Condensate pan	18	P	Plastic	
		A	Aluminium	Compulsory with electric heater
Fresh air	19	-	Without	
		A	DN125 spigot only	Only available with Large plenum
		B	Module MR DN125 15-50 m ³ /h	
		C	Module MR DN125 50-100 m ³ /h	
		D	Module MR DN125 100-125 m ³ /h	
E	DN 125 adapter for fresh air valve (must be ordered separately)			
Fresh air position	20	-	Without	
		A	On the return, hydraulic side	Only available with Large plenum
		B	On the return, opposite the hydraulics	
		C	On the linear return	
		D	On the supply air, opposite the hydraulics	
F	On the supply air, hydraulic side			
Relay for electric heater	21	-	Without	
		R	with relay	Only for "electrics box" option
Electrical protection	22	-	Without	
		F	Fuse disconnect switch	
		C	Circuit breaker	
Air sensor	23	-	Without	
		A	Return sensor	only for Control = NTC or WTC
		B	Supply air sensor	
		C	Return air sensor & supply air sensor	
Water temperature sensor	24	-	Without	
		A	With water temperature sensor	changeover sensor with four-way valve
Spigot protection	25	-	Without	
		A	Hose protection	
Hose	26	-	Without	
		F	With hoses	
Specific labelling	27	-	Without specific labelling	
		A	Individual specific labelling	
		B	Specific labelling for the pallet	
		C	Individual and pallet specific labelling	
Application	28	C	Suspended ceiling	
		F	Raised floor	

Key:

Basic configuration

7 - 42EP PERFORMANCE DATA

7.1 - Physical and electrical data at Eurovent conditions - 42EP - Size 0

With G3 filter - without plenum

42EP 2-Pipe	029									039								
	2	3	4	5	6	7	8	9		2	3	4	5	6	7	8	9	
Fan speed	LS		MS			HS				LS		MS			HS			
Débit d'air m ³ /h	67	115	157	197	231	273	305	324		74	128	177	222	266	317	355	379	
Operating pressure Pa	9	27	50	78	107	150	187	211		6	17	32	50	72	102	128	146	
Cooling mode, 2-pipe*																		
Total cooling capacity kW	0,4	0,6	0,8	0,9	1,1	1,2	1,3	1,3		0,5	0,8	1,0	1,2	1,4	1,6	1,7	1,8	
Sensible cooling capacity kW	0,3	0,5	0,7	0,8	0,9	1,0	1,1	1,2		0,4	0,6	0,8	1,0	1,2	1,4	1,5	1,6	
Water flow rate l/h	71	106	136	161	181	203	217	222		87	137	178	214	245	278	300	310	
Water pressure drop kPa	1	3	5	6	8	10	12	12		1	2	3	5	6	8	10	11	
Water volume l	1,0									1,3								
Heating mode, 2-pipe*																		
Heating capacity kW	0,5	0,8	1,0	1,2	1,4	1,6	1,8	1,9		0,6	1,0	1,3	1,6	1,8	2,1	2,3	2,5	
Water flow rate l/h	91	136	176	212	241	277	304	322		103	165	219	268	312	363	400	426	
Water pressure drop kPa	2	4	6	8	9	11	13	14		1	3	4	6	7	9	11	12	
Water volume l																		
Electric heater	230V ±10% - 1ph - 50Hz									230V ±10% - 1ph - 50Hz								
Maximum capacity W	800									800								
Input current A	3,7									3,7								
Low capacity	500									500								
Input current A	2,3									2,3								
Sound levels																		
Supply air sound power level dB(A)	31	41	48	53	56	59	62	64		32	42	48	53	57	60	63	65	
Radiated+sound power level dB(A)	30	40	46	51	54	57	60	62		31	40	47	51	55	58	61	63	
Motor electrical data																		
Power input W	4	8	13	22	38	59	82	86		4	8	13	21	34	53	73	86	
Current A	0,043	0,063	0,094	0,147	0,223	0,335	0,447	0,553		0,043	0,063	0,094	0,147	0,223	0,335	0,447	0,553	
FCEER [energy class] 2-pipe	60	C								68	B							
FCCOP [energy class] 2-pipe	78	B								84	B							

Declared speeds: LS = Low Speed | MS = Medium Speed | HS = High Speed



Eurovent certified values

- * Eurovent conditions: Air inlet = 27 °C (19 °C wb) – water inlet = 7 °C, ΔT 5K
- ** Eurovent conditions: Air inlet = 20 °C (15 °C wb max) – water inlet = 45 °C, ΔT 5K
- *** Eurovent conditions: Air inlet = 20 °C (15 °C wb max) – water inlet = 65 °C, ΔT 10K

7 - 42EP PERFORMANCE DATA

42EP 4-Pipe		049							
Fan speed		2	3	4	5	6	7	8	9
		LS			MS		HS		
Air flow	m ³ /h	78	122	173	214	255	308	345	368
Operating pressure	Pa	7	16	33	50	72	104	131	148
Cooling mode, 4-pipe*									
Total cooling capacity	kW	0,5	0,8	1,0	1,2	1,4	1,6	1,7	1,8
Sensible cooling capacity	kW	0,4	0,6	0,8	1,0	1,1	1,3	1,5	1,6
Water flow rate	l/h	93	133	176	208	238	274	295	305
Water pressure drop	kPa	1	2	3	5	6	8	9	10
Water volume	l	1,3							
Heating mode, 4-pipe***									
Heating capacity	kW	0,8	1,1	1,3	1,5	1,7	2,0	2,2	2,3
Water flow rate	l/h	139	183	229	266	300	342	371	391
Water pressure drop	kPa	3	6	8	11	13	16	18	19
Water volume	l	0,5							
Sound levels									
Supply air sound power level	dB(A)	32	41	48	53	57	60	62	65
Intake+radiated sound power level	dB(A)	31	40	47	51	55	58	60	62
Motor electrical data									
Power input	W	4	8	13	22	38	59	82	86
Current	A	0,043	0,063	0,094	0,147	0,223	0,335	0,447	0,553
FCEER [energy class]	4-pipe	69	B						
FCCOP [energy class]	4-pipe	97	A						

Declared speeds: LS = Low Speed | MS = Medium Speed | HS = High Speed



Eurovent certified values

* Eurovent conditions: Air inlet = 27 °C (19 °C wb) – water inlet = 7 °C, ΔT 5K

** Eurovent conditions: Air inlet = 20 °C (15 °C wb max) – water inlet = 45 °C, ΔT 5K

*** Eurovent conditions: Air inlet = 20 °C (15 °C wb max) – water inlet = 65 °C, ΔT 10K

7 - 42EP PERFORMANCE DATA

7.2 - Physical and electrical data at Eurovent conditions - 42EP - Size 1

With G3 filter - without plenum

42EP 2-Pipe	129									139								
	2	3	4	5	6	7	8	9		2	3	4	5	5,7	7	8	9	
Fan speed	LS		MS			HS				LS		MS			HS			
Air flow m ³ /h	85	137	182	220	267	310	346	365		97	171	218	271	310	378	420	446	
Operating pressure Pa	11	28	50	73	108	145	180	202		5	15	25	38	50	74	92	104	
Cooling mode, 2-pipe*																		
Total cooling capacity kW	0,6	0,9	1,2	1,3	1,5	1,7	1,8	1,9		0,7	1,2	1,5	1,8	2,0	2,4	2,5	2,6	
Sensible cooling capacity kW	0,4	0,7	0,9	1,0	1,2	1,3	1,4	1,5		0,5	0,9	1,1	1,4	1,5	1,8	2,0	2,1	
Water flow rate l/h	120	180	230	260	310	350	380	390		128	212	261	313	346	406	436	452	
Water pressure drop kPa	4	9	14	18	23	28	32	34		3	7	11	15	19	24	28	30	
Water volume l	1,4									2,0								
Heating mode, 2-pipe*																		
Heating capacity kW	0,7	1,0	1,3	1,5	1,8	2,0	2,2	2,3		0,8	1,3	1,7	2,0	2,3	2,7	3,0	3,1	
Water flow rate l/h	120	180	230	260	310	350	380	390		136	230	287	349	389	466	510	540	
Water pressure drop kPa	4	8	13	17	22	27	31	33		2	6	10	13	16	21	25	27	
Water volume l	1,4									2,0								
Electric heater																		
	230V ±10% - 1ph - 50Hz									230V ±10% - 1ph - 50Hz								
Maximum capacity W	1000									1000								
Input current A	4,6									4,6								
Medium capacity																		
Input current A	3,7									3,7								
Low capacity																		
Input current A	2,3									2,3								
Sound levels																		
Supply air sound power level dB(A)	32	43	50	55	59	62	65	67		33	43	50	55	58	63	65	68	
Radiated+sound power level dB(A)	33	41	48	52	57	60	63	64		30	42	47	52	55	60	62	64	
Motor electrical data																		
Power input W	5	8	16	25	39	60	80	88		5	8	16	25	39	60	80	88	
Current A	0,05	0,08	0,14	0,22	0,33	0,47	0,60	0,68		0,05	0,08	0,14	0,22	0,33	0,47	0,60	0,68	
FCEER [energy class] 2-pipe	75	B								88	A							
FCCOP [energy class] 2-pipe	76	B								100	A							

Declared speeds: LS = Low Speed | MS = Medium Speed | HS = High Speed



Eurovent certified values

- * Eurovent conditions: Air inlet = 27 °C (19 °C wb) – water inlet = 7 °C, ΔT 5K
- ** Eurovent conditions: Air inlet = 20 °C (15 °C wb max) – water inlet = 45 °C, ΔT 5K
- *** Eurovent conditions: Air inlet = 20 °C (15 °C wb max) – water inlet = 65 °C, ΔT 10K

7 - 42EP PERFORMANCE DATA

42EP 4-Pipe		149							
Fan speed		2	3	4	5	5,8	7	8	9
		LS				MS	HS		
Air flow	m ³ /h	88	151	217	262	306	368	410	437
Operating pressure	Pa	4	12	25	37	50	73	90	102
Cooling mode, 4-pipe*									
Total cooling capacity	kW	0,7	1,1	1,5	1,8	2,0	2,3	2,5	2,6
Sensible cooling capacity	kW	0,5	0,8	1,1	1,3	1,5	1,8	2,0	2,1
Water flow rate	l/h	119	191	259	302	339	396	428	444
Water pressure drop	kPa	2	6	11	14	18	24	27	29
Water volume	l	1,4							
Heating mode, 4-pipe***									
Heating capacity	kW	1,0	1,5	1,9	2,2	2,4	2,7	2,9	3,1
Water flow rate	l/h	174	252	325	371	411	470	505	528
Water pressure drop	kPa	7	15	23	29	33	41	46	50
Water volume	l	0,7							
Electric heater		230V ±10% - 1ph - 50Hz							
Maximum capacity	W	1000							
Input current	A	4,6							
Sound levels									
Supply air sound power level	dB(A)	33	43	50	55	59	63	65	68
Intake+radiated sound power level	dB(A)	30	40	47	52	55	59	62	64
Motor electrical data									
Power input	W	5	8	16	25	39	60	80	88
Current	A	0,05	0,08	0,14	0,22	0,33	0,47	0,6	0,684
FCEER [energy class]	4-pipe	82	B						
FCCOP [energy class]	4-pipe	112	A						

Declared speeds: LS = Low Speed | MS = Medium Speed | HS = High Speed



Eurovent certified values

* Eurovent conditions: Air inlet = 27 °C (19 °C wb) – water inlet = 7 °C, ΔT 5K

** Eurovent conditions: Air inlet = 20 °C (15 °C wb max) – water inlet = 45 °C, ΔT 5K

*** Eurovent conditions: Air inlet = 20 °C (15 °C wb max) – water inlet = 65 °C, ΔT 10K

7 - 42EP PERFORMANCE DATA

7.3 - Physical and electrical data at Eurovent conditions - 42EP - Size 2

42EP 2-Pipe	229									239								
	2	3	4	4,8	6	7	8	9		2	3	4	5	6	7	8	9	
Fan speed	LS			MS		HS				LS			MS		HS			
Air flow m ³ /h	147	264	394	458	567	677	748	797		141	247	364	453	542	649	719	766	
Operating pressure Pa	5	17	37	50	77	109	134	152		5	15	32	50	72	103	127	144	
Cooling mode, 2-pipe*																		
Total cooling capacity kW	1,02	1,61	2,23	2,48	2,88	3,22	3,38	3,45		1,11	1,79	2,51	2,98	3,41	3,87	4,13	4,26	
Sensible cooling capacity kW	0,76	1,23	1,74	1,97	2,33	2,67	2,86	2,99		0,79	1,31	1,88	2,26	2,63	3,04	3,30	3,47	
Water flow rate l/h	176	277	382	426	494	553	581	593		190	306	431	511	586	664	709	731	
Water pressure drop kPa	14	34	68	87	106	118	127	127		7	19	34	45	57	71	81	87	
Water volume l	1,7									2,5								
Heating mode, 2-pipe*																		
Heating capacity kW	1,14	1,81	2,55	2,88	3,42	3,92	4,24	4,47		1,15	1,89	2,71	3,27	3,83	4,45	4,87	5,16	
Water flow rate l/h	196	312	439	495	589	676	730	770		198	326	467	564	659	766	838	889	
Water pressure drop kPa	12	29	51	62	81	103	117	127		6	15	27	38	49	63	73	80	
Water volume l	1,7									2,5								
Electric heater																		
	230V ±10% - 1ph - 50Hz									230V ±10% - 1ph - 50Hz								
Maximum capacity W	1600									1600								
Input current A	7,3									7,3								
High capacity																		
Input current A	4,6									4,6								
Medium capacity																		
Input current A	3,7									3,7								
Low capacity																		
Input current A	2,3									2,3								
Sound levels																		
Supply air sound power level dB(A)	36	45	52	56	60	63	66	68		37	46	52	57	61	64	66	69	
Radiated+sound power level dB(A)	33	43	49	53	58	61	64	66		33	43	49	54	58	61	64	66	
Motor electrical data																		
Power input W	9	14	26	38	63	96	133	167		9	14	26	38	63	96	133	167	
Current A	0,11	0,16	0,25	0,38	0,58	0,84	1,08	1,31		0,11	0,16	0,25	0,38	0,58	0,84	1,08	1,31	
FCEER [energy class] 2-pipe	71	B								78	B							
FCCOP [energy class] 2-pipe	83	B								85	A							

Declared speeds: LS = Low Speed | MS = Medium Speed | HS = High Speed



Eurovent certified values

- * Eurovent conditions: Air inlet = 27 °C (19 °C wb) – water inlet = 7 °C, ΔT 5K
- ** Eurovent conditions: Air inlet = 20 °C (15 °C wb max) – water inlet = 45 °C, ΔT 5K
- *** Eurovent conditions: Air inlet = 20 °C (15 °C wb max) – water inlet = 65 °C, ΔT 10K

7 - 42EP PERFORMANCE DATA

42EP 4-Pipe		249							
Fan speed		2	3	4	5	6	7	8	9
		LS			MS		HS		
Air flow	m ³ /h	139	247	351	451	532	632	702	755
Operating pressure	Pa	5	15	31	50	70	99	122	141
Cooling mode, 4-pipe*									
Total cooling capacity	kW	1,1	1,8	2,5	3,0	3,4	3,8	4,1	4,2
Sensible cooling capacity	kW	0,8	1,3	1,8	2,3	2,6	3,0	3,3	3,4
Water flow rate	l/h	191	316	421	516	583	658	702	729
Water pressure drop	kPa	7	19	32	45	55	69	78	86
Water volume	l	2,5							
Heating mode, 4-pipe***									
Heating capacity	kW	1,5	2,3	2,9	3,4	3,7	4,2	4,5	4,8
Water flow rate	l/h	260	393	495	579	641	723	780	825
Water pressure drop	kPa	19	39	58	76	90	111	125	136
Water volume	l	1,00							
Sound levels									
Supply air sound power level	dB(A)	37	46	52	57	61	64	66	69
Radiated+sound power level	dB(A)	33	42	49	54	58	61	64	66
Motor electrical data									
Power input	W	9	15	26	43	65	100	133	168
Current	A	0,11	0,16	0,25	0,38	0,58	0,84	1,083	1,308
FCEER [energy class]	4-pipe	78	B						
FCCOP [energy class]	4-pipe	98	A						

Declared speeds: LS = Low Speed | MS = Medium Speed | HS = High Speed



Eurovent certified values

* Eurovent conditions: Air inlet = 27 °C (19 °C wb) – water inlet = 7 °C, ΔT 5K

** Eurovent conditions: Air inlet = 20 °C (15 °C wb max) – water inlet = 45 °C, ΔT 5K

*** Eurovent conditions: Air inlet = 20 °C (15 °C wb max) – water inlet = 65 °C, ΔT 10K

8 - OPERATING LIMITS

	Cooling mode	Heating mode
Water circuit	Min. inlet temperature > 5 °C pure water	Max. inlet temperature > 80 °C pure water
	< 40% ethylene / propylene glycol	< 40% ethylene / propylene glycol
	Water side pressure < 16 bar (1600 kPa)	Water side pressure < 16 bar (1600 kPa)
Ambient temperature and humidity	T < 27°C / 65% relative humidity	T < 40°C
	or humidity weight < 14.7 g/kg dry air	
Supply air temperature	T > 12°C with maximum ambient humidity conditions (14.7 g/kg dry air)	T < 60°C with supply plenum and spigots application
		Recommendation to avoid stratification T < 35°C
EC Motor - Electrical input	Min: 200 V	Min: 200 V
	Max: 240 V	Max: 240 V
	60 or 50 Hz -1ph	60 or 50 Hz -1ph

NOTE: All performances data certified by Eurovent are based on 50Hz application.
Carrier does not guarantee the same level of performance when the unit is operating at 60 Hz; the rpm and power input of the fan motor are usually higher.

9 - MINIMUM AIR FLOW WITH ELECTRIC HEATER

Minimum control voltage for an operating pressure of 50 Pa

Size 42EP	Auxiliary heater option			
	Low	Medium	High	Very high
0	2 volts	3 volts	NA	NA
1	2 volts	3 volts	3 volts	NA
2	2 volts	3 volts	3 volts	3 volts

10 - GUIDE TO THE SPECIFICATIONS FOR THE 42EP

The new generation 42EP ductable fan coil unit offers a innovative solution with a very slimline range (just 150 mm deep) which can be adapted to both the new build and renovation markets to gain height underneath the suspended ceiling and improve the well-being of occupants.

This new range is available in 3 casing sizes with a cooling capacity range of 1 to 3 kW at Eurovent conditions running at 50 Pa at medium speed. The unit can cover a pressure range of up to 150 Pa.

The 42EP unit complies with the provisions of the following European directives:

- 2006/42/EC (Machinery),
- 2014/35/EU (LVD),
- 2014/30/EU (EMC),
- 2011/65/EU (RoHS),
- 2009/125/EC (Eco Design) & regulation 327/2011/UE,
- Regulation (EC) no. 1907/2006 (REACH),

And the corresponding UK legislation:

- Supply of Machinery (Safety) Regulations 2008,
- Electrical Equipment (Safety) Regulations 2016,
- Electromagnetic Compatibility Regulations 2016,
- The Restriction of the Use of Certain Hazardous Substances in Electrical and Electronic Equipment Regulations 2012,
- The Ecodesign for Energy-Related Products and Energy Information Regulations 2019, and following amendments,
- UK REACH Regulations 2019.

General description

The unit(s) must be designed, manufactured and tested in a facility with an ISO 9001 certified quality assurance system and an ISO 14001 certified environmental management system.

The unit(s) must be certified by Eurovent.

The unit(s) must be tested in operation at the factory before shipment

Technical specifications

Casing

- The unit has a maximum height of 150 mm
- The 42EP is made of galvanised sheet metal with full high efficiency insulation to optimise the thermal and acoustic performances of the unit. In order to comply with the various local regulations (fire class), the unit is available with both class M1 type insulation (according to NF P 92-507) and Euroclass level B-s3-d0 insulation (according to EN 13501). It is also equipped with antivibration mounts as standard.
- The 42EP can be equipped with plenums factory-fitted on the supply air and on the return o Plenums with a linear arrangement and Ø 125 mm spigots (option of equivalent 200 mm oblong spigots on request) o Plenums with 2 lateral Ø 125 mm spigots (option of equivalent 200 mm oblong spigots on request)

Fan motor assembly

- The 42EP is equipped with a plug fan combined with a low energy consumption (LEC) electronically commutated motor that meets the new building energy performance objectives thanks to auto-adaptive adjustment of the air flow rate from 0 to 100% ensuring perfect cooling and heating conditions in the room.

Heating or cooling coil

- 42EP units shall be equipped with a 2-pipe air coil for operation in heating or cooling mode only or heating/cooling changeover or a 4-pipe heating and cooling coil The water coils shall be fitted with manual drain valves and air vents.
- The air coils are manufactured with copper pipes and aluminium louver fins which are mechanically bonded.
- The maximum operating pressure is 16 bar.

- The air coils are equipped with female G1/2" water inlet and outlet couplings.
- The air coil is fitted with a drawer which facilitates removal for maintenance

Single unit condensate drain pan

- The 42EP drain pan is a single unit made from either polypropylene or aluminium and insulated with 5 mm of foam. The condensate connection diameter is 16 mm (external)

Electric heater

- The unit with a 2-pipe coil can be equipped with a resistive wire type electric heater. The capacity of the air coil will be adapted to the unit with a minimum air flow required to prevent any damage.
- The heater has a double safety feature: an integrated self-hold safety thermostat with automatic reset and a thermal fuse

Filter

- The 42EP shall at least be provided with filter G3 class according to EN 779.

Controller range

- A-B-C-D type electronic thermostats for all applications
 - Type C: 2 pipes with EC motor
 - Type D: 4 pipes or 2 pipes with electric heaters and EC motor
- NTC controller
 - Communication PID controller compatible with the Aquasmart Evolution System package (proprietary CCN protocol)
 - Manages the motorised louvres of the grille in manual or automatic mode
 - Manages the EC motor to optimise comfort
 - Manages a CO₂ sensor to improve air quality
- WTC controller
 - BACnet or LON open communication protocol
 - Communication PID controller
 - Large range of user interfaces, wall mounted or remote
 - Manages the motorised louvres of the grille in manual or automatic mode
 - Manages the EC motor to optimise comfort
 - Manages a CO₂ sensor to improve air quality
 - Optional management modules for lighting and/or blinds, actuated from the same user interface
 - Large range of sensors (light, presence, etc.)

Valve options

- Control Two or four-ways bodies with 230V power supply:
 - On/Off 230V actuator
 - Floating 3-point 230 V actuator
- Control and balancing Two-way valves. Two-in-one designed valves enabling both the setting of the nominal waterflow in the fan-coil and the waterflow control with the NTC or the WTC, with 230 V power supply:
 - On/Off 230V actuator
 - Floating 3-point 230V actuator

The quality management system of this product's assembly site has been certified in accordance with the requirements of the ISO 9001 standard (latest current version) after an assessment conducted by an authorized independent third party.

The environmental management system of this product's assembly site has been certified in accordance with the requirements of the ISO 14001 standard (latest current version) after an assessment conducted by an authorized independent third party.

The occupational health and safety management system of this product's assembly site has been certified in accordance with the requirements of the ISO 45001 standard (latest current version) after an assessment conducted by an authorized independent third party.

Please contact your sales representative for more information.

Order No.: 10546, 12.2022. Supersedes order No.: 10546, 12.2019.

Carrier S.C.S, Rte de Thil - 01120 Montluel, France.

Manufacturer reserves the right to change any product specifications without notice.

The illustrations in this document are for illustrative purposes only and not part of any offer for sale or contract. The manufacturer reserves the right to change the design at any time without notice.