



Fan Coil Unit
Cassette
TopLine ECM
7-8

TopLine ECM 7-8



TABLE OF CONTENTS

Introduction	p. 4
Main components	p. 5
Performances	p. 7
Cooling emission	p. 8
Heating emission	p. 11
Water side pressure drops	p. 12
Operating limits	p. 13
Dimension and weight	p. 14
Air throw	p. 15
Accessories	p. 16
TL-ECM version	p. 18
Controls for TL-ECM units	p. 18
TL-ECM-MB version	p. 19
Controls for TL-ECM-MB units	p. 20

INTRODUCTION

Innovating and beautiful design, perfect to meet all air-conditioning requirements of wide environments, 2 different models, high control flexibility, easy maintenance: the new cassette fan coil unit **TopLine ECM 7-8** is the result of an extended technical and design development aimed at achieving the highest level in terms of performance, silent operation and control possibility.

The air diffuser has an highly attractive aesthetical appearance, very innovative, and is also able to offer the best air distribution performance thanks to long computer studies and laboratory tests. The standard colour is RAL 9003, other colours available on request.

The bigger sizes allow the best outcome in terms of quietness and of price/performance ratio for these high capacity models.

Every unit can be supplied with 1 coil (2 pipe system) and a possible electric heater or with 2 coils (4 pipe system). Each model can have fresh air intake and a remote air diffuser can be connected to the unit.

The float switch centrifugal pump is particularly silent, with 650 mm of maximum head.

In addition to temperature and speed standard controls, automatic speed selection is also available. More than one unit can be connected to a single control.

All the **TopLine ECM 7-8** units can be supplied in **MB** version. This version includes a wide range of controls, including the infra-red remote control, which allows managing one single unit or several units by using the Bus communication protocol. The units can be connected to the most common automatic building management systems.

In the MB version it is possible to control at the same time the (motorized) outlet louvers with the remote-control or with the T-MB wall control.

The outlet louvers position themselves automatically according to the selected operation (summer-winter) and can be managed with the swing mode, that guarantees a complete air distribution in the environment.

Both versions, the **TL-ECM** and the **TL-ECM-MB** ones can be supplied with electric heater.

The range **TopLine ECM 7-8** uses an innovative brushless synchronous permanent magnet electric motor controlled by an inverter board that is directly installed on the unit.

The air flow can be varied continuously with a 1-10 V signal from controls or by independent controllers (programmable controllers with a 1-10 V output).

The extreme efficiency, also at a low speed, makes possible a great reduction in electric consumption (more than 75% less in comparison to a traditional motor) with absorption values, under normal operating conditions, that are no greater than 20 Watt in the entire range.

The brushless motor is characterised by a constant synchronous speed, independently of the applied load, that depends only on the motor power supply frequency, which is modulated by the inverter.

it consumes less because:

- The motor always works at its point of maximum efficiency.
- in the brushless motor, the rotor's permanent magnets generate the magnetising power autonomously.
- the motor always operates at the synchronous speed, as a result there are no induced currents that reduce efficiency

The main advantages are:

- large reduction in energy consumption, thanks to an optimal response to the thermal load of the environment during every moment of the day.
- operating silence at all rotation speeds.
- ability to operate at any rotation speed.

MAIN COMPONENTS

Air diffuser

Intake grids, frame and adjustable air distribution louvers on each side, made of ABS. In the **TL-ECM-MB** version the outlet louvers are adjustable with remote control or with T-MB wall control (for the **TL-ECM** version manually only).

The intake and air distribution grids are available with both, the G0 filter and **the F7 filter**.

- RSNA Version: white ABS, RAL 9003.
- RSNB Version: in ABS one single color to choose.

RSNA Version



RSNB Version



Casing

It is made of galvanized steel with internal thermal insulation with polyolefin (PO) foam (class M1) and external anti-condensate lining.

Control panel

- **TL-ECM / TL-ECM-E** version

It consists of the pump control circuit board and the inverter circuit board.

- **TL-ECM-MB / TL-ECM-MB-E** version

It consists of the MB electronic board (that integrates pump control) and the inverter board.

The diffusion louvers are adjustable with the infra-red remote control or with T-MB wall control.

Fan assembly

The fan assembly, secured on anti-vibration mountings, is particularly silent.

The radial fan has been designed to optimise performance, using wing profile blades with a shape that reduces turbulence, increasing efficiency and reducing noise.

The fans are connected to a three phase permanent magnet brushless electronic motor that is controlled with reconstructed current according to a BLAC sinusoidal wave.

The inverter board that controls the motor operation is powered by 230 Volt, single-phase and, with a switching system, it generates a three-phase frequency modulated, wave form power supply.

The electric power supply required for the machine is therefore single-phase with voltage of 230 - 240 V and frequency of 50 - 60 Hz.

Coil

Made of copper tubes with bonded aluminium fins for maximum transfer contact.

3 row coil for 2 pipe models and 2,5 + 1/2 row coil for 4 pipe models (the heating row is on the inside part of the coil).

The heat exchanger is not suitable for use in corrosive atmosphere or in environments where aluminium may be subject to corrosion.

Condensate collection tray

High density polystyrene foam condensate tray, shaped in order to optimize the air diffusion.

Fire retardant rating B1 to DIN 4102.

TopLine ECM 7-8 | MAIN COMPONENTS

Filter

Easy access to the filter that is available in both versions, in the G0 (synthetic regenerable washable) and in the F7 one (to change at the end of its life-cycle).

Condensate pump

Float switch centrifugal pump with 650 mm of maximum head, integral to the unit and wired to the control panel on the outside of the casing.

Valve set

Two or three way valves for ON/OFF operation, with pipe mounting kit and ball valves

Version with electric heater (3 kW) TL-ECM-E / TL-ECM-MB-E

The 2 pipe model Cassette units are available with electric heater.

The electric heater is controlled in place of the hot water valve and not as integration to it.

The electric heaters are hermetically sealed and supplied inside the coil pipes and therefore can be only factory mounted.

The electric heaters of the unit can be for 230Vac 1Ph 50-60Hz or 400Vac 3Ph 50-60Hz supply.

The Cassette fan coil unit includes no. 2 safety thermostats which intervene in case of internal over-heating, opening an auxiliary power relay (included in the electrical panel) which stops the power supply to the electric heaters.



PERFORMANCES

Technical features for 2 pipe unit

The following standard rating conditions are used:

COOLING

Entering air temperature: + 27 °C d.b. + 19 °C w.b.
Water temperature: +7 °C E.W.T. +12 °C L.W.T.

HEATING

Entering air temperature: + 20 °C
Water temperature: +45 °C E.W.T. +40 °C L.W.T.

MODEL	Speed	TL-ECM 7.2T					TL-ECM 8.2T				
		1 MIN	3	5 MED	7,5	10 MAX	1 MIN	3	5 MED	7,5	10 MAX
Air flow	m ³ /h	790	1040	1290	1600	1905	1025	1340	1650	2060	2480
Cooling total emission	kW	6,36	7,95	9,43	11,10	12,60	7,86	9,72	11,38	13,35	15,13
Cooling sensible emission	kW	4,45	5,65	6,77	8,09	9,31	5,58	7,00	8,30	9,88	11,41
Heating	kW	6,18	7,93	9,59	11,55	13,39	7,82	9,91	11,86	14,29	16,40
Cooling water side pressure drop	kPa	6,6	9,8	13,4	18,0	22,7	9,6	14,1	18,8	25,2	31,8
Heating water side pressure drop	kPa	5,4	8,4	11,8	16,5	21,5	8,2	12,5	17,3	24,2	31,0
Sound power Lw	dB(A)	38	44	49	54	58	44	50	55	60	64
Sound pressure ⁽¹⁾	dB(A)	29	35	40	45	49	35	41	46	51	55
Motor power input	W	13	22	35	59	93	21	38	64	113	183
Condensate drain pump power absorption	W						10				
Water content	l						4,6				
Length	mm						869				
Depth	mm						869				
Height	mm						304				

(1) The sound pressure levels are 9 dB (A) lower than the sound power levels, apply to the reverberant field of a 100 m³ room and a reverberation time of 0.5 sec.

Technical features for 4 pipe unit

The following standard rating conditions are used:

COOLING

Entering air temperature: + 27 °C d.b. + 19 °C w.b.
Water temperature: +7 °C E.W.T. +12 °C L.W.T.

HEATING

Entering air temperature: + 20 °C
Water temperature: +65 °C E.W.T. +55 °C L.W.T.

MODEL	Speed	TL-ECM 7.6T					TL-ECM 8.6T				
		1 MIN	3	5 MED	7,5	10 MAX	1 MIN	3	5 MED	7,5	10 MAX
Air flow	m ³ /h	790	1040	1290	1600	1905	1025	1340	1650	2060	2480
Cooling total emission	kW	6,07	7,53	8,86	10,35	11,61	7,45	9,10	10,59	12,30	13,59
Cooling sensible emission	kW	4,33	5,46	6,53	7,74	8,87	5,40	6,73	7,96	9,44	10,68
Heating	kW	6,01	7,27	8,40	9,63	10,55	7,19	8,62	9,80	11,05	12,17
Cooling water side pressure drop	kPa	7,0	10,3	13,8	18,3	22,6	10,1	14,5	19,1	25,2	30,4
Heating water side pressure drop	kPa	7,2	10,2	13,2	16,9	19,9	10,0	13,8	17,4	21,6	25,7
Sound power Lw	dB(A)	38	44	49	54	58	44	50	55	60	64
Sound pressure ⁽¹⁾	dB(A)	29	35	40	45	49	35	41	46	51	55
Motor power input	W	13	22	35	59	93	21	38	64	113	183
Condensate drain pump power absorption	W						10				
Cooling water content	l						3,6				
Heating water content	l						1,2				
Length	mm						869				
Depth	mm						869				
Height	mm						304				

(1) The sound pressure levels are 9 dB (A) lower than the sound power levels, apply to the reverberant field of a 100 m³ room and a reverberation time of 0.5 sec.

COOLING EMISSION

Entering air temperature: 27 °C – R.H.: 50%

Model	Speed	Vdc	WT: 7 / 12 °C				WT: 8 / 13 °C				WT: 10 / 15 °C				WT: 12 / 17 °C				
			Qv m ³ /h	Pc kW	Ps kW	Qw l/h	Dp(c) kPa	Pc kW	Ps kW	Qw l/h	Dp(c) kPa	Pc kW	Ps kW	Qw l/h	Dp(c) kPa	Pc kW	Ps kW	Qw l/h	Dp(c) kPa
TL-ECM 7.2T	MAX	10	1905	13,52	9,25	2341	25,7	12,21	8,73	2116	21,3	9,70	7,68	1684	14,0	6,96	6,96	1213	7,7
		7,5	1600	11,90	8,07	2058	20,4	10,77	7,59	1862	16,9	8,58	6,69	1486	11,2	6,63	5,86	1150	7,0
	MED	5	1290	10,11	6,77	1744	15,1	9,14	6,36	1577	12,6	7,31	5,60	1264	8,3	5,65	4,90	978	5,2
		3	1040	8,52	5,65	1470	11,1	7,74	5,32	1335	9,3	6,19	4,66	1068	6,2	4,77	4,08	825	3,8
	MIN	1	790	6,80	4,45	1172	7,4	6,19	4,19	1067	6,2	4,99	3,68	860	4,2	3,85	3,22	665	2,6
TL-ECM 8.2T	MAX	10	2480	16,21	11,31	2819	35,9	14,60	10,67	2543	29,7	11,59	9,41	2025	19,5	8,49	8,49	1491	11,1
		7,5	2060	14,28	9,84	2476	28,5	12,92	9,28	2242	23,6	10,23	8,17	1779	15,4	7,39	7,39	1291	8,6
	MED	5	1650	12,18	8,27	2106	21,3	11,03	7,79	1907	17,7	8,74	6,85	1515	11,5	6,78	6,01	1177	7,2
		3	1340	10,41	6,98	1797	16,0	9,43	6,57	1628	13,3	7,51	5,77	1299	8,8	5,81	5,06	1005	5,5
	MIN	1	1025	8,42	5,58	1453	10,9	7,64	5,25	1318	9,1	6,13	4,61	1057	6,0	4,73	4,03	816	3,8
TL-ECM 7.6T	MAX	10	1905	12,40	8,78	2149	25,5	11,20	8,31	1942	21,1	8,93	7,36	1553	13,9	6,65	6,65	1160	8,2
		7,5	1600	11,03	7,69	1908	20,6	10,01	7,28	1731	17,2	7,97	6,43	1381	11,3	5,83	5,83	1013	6,4
	MED	5	1290	9,47	6,49	1635	15,6	8,57	6,11	1480	12,9	6,84	5,40	1183	8,6	5,32	4,75	921	5,4
		3	1040	8,07	5,44	1391	11,6	7,30	5,13	1259	9,7	5,82	4,51	1005	6,4	4,53	3,97	782	4,0
	MIN	1	790	6,50	4,32	1121	7,9	5,88	4,06	1014	6,6	4,73	3,57	816	4,4	3,67	3,14	634	2,8
TL-ECM 8.6T	MAX	10	2480	14,48	10,52	2522	34,0	13,08	9,98	2281	28,2	10,41	8,85	1822	18,6	7,94	7,94	1396	11,4
		7,5	2060	13,05	9,31	2264	28,0	11,81	8,82	2051	23,3	9,40	7,81	1635	15,3	7,04	7,04	1231	9,1
	MED	5	1650	11,27	7,87	1949	21,4	10,22	7,45	1768	17,8	8,13	6,58	1409	11,7	5,97	5,97	1038	6,7
		3	1340	9,74	6,69	1681	16,4	8,82	6,30	1524	13,6	7,04	5,57	1217	9,0	5,47	4,90	947	5,7
	MIN	1	1025	7,98	5,38	1376	11,4	7,22	5,07	1246	9,5	5,79	4,47	1000	6,3	4,48	3,92	774	3,9

WT: Water temperature
Vdc: Inverter power
Qv: Air flow
Pc: Cooling total emission
Ps: Cooling sensible emission
Qw: Water flow rate
Dp(c): Cooling water side pressure drop

Entering air temperature 26 °C – R.H.: 50%

Model	Speed	Vdc	Qv m ³ /h	WT: 7 / 12 °C				WT: 8 / 13 °C				WT: 10 / 15 °C				WT: 12 / 17 °C			
				Pc kW	Ps kW	Qw l/h	Dp(c) kPa	Pc kW	Ps kW	Qw l/h	Dp(c) kPa	Pc kW	Ps kW	Qw l/h	Dp(c) kPa	Pc kW	Ps kW	Qw l/h	Dp(c) kPa
TL-ECM 7.2T	MAX	10	1905	12,13	8,75	2102	21,2	10,85	8,19	1883	17,3	8,55	7,21	1487	11,2	6,39	6,39	1116	6,6
		7,5	1600	10,67	7,61	1846	16,8	9,56	7,13	1655	13,7	7,57	6,28	1311	8,9	5,58	5,58	971	5,1
	MED	5	1290	9,07	6,38	1565	12,5	8,16	5,98	1410	10,3	6,45	5,25	1115	6,6	4,70	4,70	814	3,7
		3	1040	7,67	5,33	1322	9,2	6,90	4,99	1190	7,6	5,46	4,38	943	4,9	4,17	3,82	721	3,0
	MIN	1	790	6,13	4,21	1056	6,1	5,53	3,94	954	5,1	4,39	3,45	757	3,3	3,36	3,01	580	2,0
TL-ECM 8.2T	MAX	10	2480	14,49	10,67	2523	29,4	12,94	10,03	2257	23,9	10,26	8,85	1797	15,7	7,78	7,78	1370	9,5
		7,5	2060	12,78	9,30	2218	23,3	11,44	8,72	1988	19,0	9,04	7,68	1574	12,4	6,79	6,79	1187	7,4
	MED	5	1650	10,93	7,80	1891	17,5	9,78	7,31	1694	14,3	7,72	6,43	1338	9,2	5,72	5,72	995	5,4
		3	1340	9,35	6,59	1615	13,2	8,40	6,17	1451	10,8	6,63	5,42	1147	7,0	4,84	4,84	840	3,9
	MIN	1	1025	7,58	5,27	1307	9,0	6,82	4,94	1176	7,4	5,40	4,32	932	4,8	4,12	3,77	713	2,9
TL-ECM 7.6T	MAX	10	1905	11,14	8,33	1932	21,0	9,94	7,83	1725	17,0	7,93	6,93	1380	11,3	6,10	6,10	1065	7,0
		7,5	1600	9,95	7,30	1721	17,1	8,88	6,84	1538	13,9	7,04	6,04	1221	9,0	5,35	5,35	931	5,5
	MED	5	1290	8,52	6,13	1471	12,9	7,62	5,76	1317	10,5	6,03	5,07	1043	6,8	4,53	4,53	785	4,0
		3	1040	7,25	5,15	1251	9,6	6,51	4,82	1124	7,9	5,15	4,24	889	5,1	3,80	3,80	658	2,9
	MIN	1	790	5,85	4,08	1009	6,5	5,27	3,83	909	5,4	4,18	3,36	722	3,5	3,21	2,94	555	2,2
TL-ECM 8.6T	MAX	10	2480	13,03	10,00	2272	28,1	11,64	9,41	2033	22,9	8,61	8,61	1512	13,3	7,26	7,26	1280	9,7
		7,5	2060	11,76	8,85	2042	23,2	10,50	8,31	1825	18,9	8,33	7,35	1452	12,4	6,45	6,45	1129	7,8
	MED	5	1650	10,16	7,47	1758	17,7	9,07	7,00	1571	14,4	7,17	6,19	1244	9,4	5,48	5,48	954	5,7
		3	1340	8,77	6,34	1514	13,6	7,83	5,94	1353	11,0	6,19	5,23	1071	7,1	4,67	4,67	809	4,3
	MIN	1	1025	7,17	5,08	1237	9,4	6,45	4,76	1112	7,7	5,11	4,20	882	5,0	3,76	3,76	650	2,9

- WT:** Water temperature
- Vdc:** Inverter power
- Qv:** Air flow
- Pc:** Cooling total emission
- Ps:** Cooling sensible emission
- Qw:** Water flow rate
- Dp(c):** Cooling water side pressure drop

TopLine ECM 7-8 | COOLING EMISSION

Entering air temperature: 25 °C – R.H.: 50%

Model	Speed	Vdc	WT: 7 / 12 °C				WT: 8 / 13 °C				WT: 10 / 15 °C				WT: 12 / 17 °C				
			Qv m³/h	Pc kW	Ps kW	Qw l/h	Dp(c) kPa	Pc kW	Ps kW	Qw l/h	Dp(c) kPa	Pc kW	Ps kW	Qw l/h	Dp(c) kPa	Pc kW	Ps kW	Qw l/h	Dp(c) kPa
TL-ECM 7.2T	MAX	10	1905	10,80	8,21	1874	17,2	9,64	7,70	1674	14,0	7,53	6,75	1310	8,9	5,82	5,82	1018	5,6
		7,5	1600	9,51	7,15	1646	13,6	8,52	6,72	1476	11,1	6,63	5,87	1151	7,0	5,09	5,09	886	4,4
	MED	5	1290	8,11	6,00	1401	10,2	7,25	5,62	1254	8,3	5,65	4,92	977	5,2	4,29	4,29	744	3,2
		3	1040	6,86	5,01	1184	7,5	6,13	4,69	1059	6,1	4,79	4,10	827	3,9	3,59	3,59	622	2,3
	MIN	1	790	5,50	3,96	948	5,1	4,93	3,70	851	4,1	3,85	3,23	665	2,6	2,86	2,86	495	1,5
TL-ECM 8.2T	MAX	10	2480	12,91	10,07	2251	24,0	11,54	9,45	2016	19,5	8,49	8,49	1492	11,2	7,07	7,07	1247	8,0
		7,5	2060	11,41	8,73	1981	19,0	10,17	8,21	1769	15,4	7,40	7,40	1292	8,7	6,18	6,18	1082	6,2
	MED	5	1650	9,75	7,33	1688	14,3	8,70	6,88	1508	11,6	6,78	6,02	1177	7,3	5,22	5,22	908	4,5
		3	1340	8,35	6,19	1442	10,8	7,46	5,80	1290	8,7	5,81	5,07	1006	5,5	4,43	4,43	768	3,4
	MIN	1	1025	6,79	4,95	1171	7,4	6,08	4,64	1050	6,0	4,73	4,05	818	3,8	3,55	3,55	615	2,3
TL-ECM 7.6T	MAX	10	1905	9,94	7,84	1726	17,2	8,89	7,38	1545	14,0	6,65	6,65	1160	8,3	5,54	5,54	969	5,9
		7,5	1600	8,82	6,86	1528	13,8	7,91	6,44	1370	11,3	5,84	5,84	1014	6,5	4,87	4,87	848	4,6
	MED	5	1290	7,59	5,77	1311	10,5	6,81	5,42	1177	8,6	5,32	4,76	921	5,4	4,13	4,13	716	3,4
		3	1040	6,49	4,84	1119	7,9	5,78	4,54	999	6,4	4,53	3,98	782	4,1	3,47	3,47	601	2,5
	MIN	1	790	5,24	3,84	903	5,3	4,69	3,59	809	4,4	3,68	3,15	635	2,8	2,78	2,78	481	1,7
TL-ECM 8.6T	MAX	10	2480	11,61	9,42	2028	22,9	10,38	8,87	1816	18,7	7,93	7,93	1396	11,5	6,58	6,58	1163	8,2
		7,5	2060	10,47	8,31	1821	18,9	9,36	7,83	1629	15,4	7,05	7,05	1231	9,2	5,86	5,86	1027	6,6
	MED	5	1650	9,03	7,01	1564	14,4	8,07	6,59	1399	11,7	5,97	5,97	1039	6,8	4,99	4,99	869	4,8
		3	1340	7,79	5,95	1347	11,0	6,99	5,59	1209	9,0	5,48	4,91	948	5,7	4,25	4,25	738	3,6
	MIN	1	1025	6,41	4,78	1106	7,7	5,72	4,48	988	6,2	4,48	3,93	774	4,0	3,43	3,43	594	2,4

WT: Water temperature
Vdc: Inverter power
Qv: Air flow
Pc: Cooling total emission
Ps: Cooling sensible emission
Qw: Water flow rate
Dp(c): Cooling water side pressure drop

HEATING EMISSION

Entering air temperature: 20 °C

Model	Speed	Vdc	Qv m ³ /h	WT: 65 / 55 °C			WT: 60 / 50 °C			WT: 50 / 40 °C			WT: 50 / 45 °C			WT: 45 / 40 °C		
				Ph kW	Qw l/h	Dp(h) kPa	Ph kW	Qw l/h	Dp(h) kPa	Ph kW	Qw l/h	Dp(h) kPa	Ph kW	Qw l/h	Dp(h) kPa	Ph kW	Qw l/h	Dp(h) kPa
TL-ECM 7.2T	MAX	10	1905	24,08	2070	17,0	21,08	1813	13,5	15,06	1295	7,6	16,34	1405	30,4	13,39	1151	21,5
		7,5	1600	20,78	1787	13,0	18,21	1566	10,4	13,05	1122	5,9	14,08	1211	23,2	11,55	993	16,5
	MED	5	1290	17,25	1483	9,3	15,14	1302	7,5	10,90	937	4,2	11,67	1003	16,6	9,59	825	11,8
		3	1040	14,26	1226	6,6	12,54	1078	5,3	9,06	779	3,0	9,63	828	11,7	7,93	682	8,4
TL-ECM 8.2T	MAX	10	2480	29,49	2536	24,4	25,79	2218	19,4	18,33	1577	10,8	20,06	1725	43,9	16,40	1411	31,0
		7,5	2060	25,69	2210	19,1	22,49	1934	15,2	16,04	1379	8,5	17,45	1500	34,2	14,29	1229	24,2
	MED	5	1650	21,33	1834	13,6	18,69	1608	10,9	13,39	1151	6,1	14,45	1243	24,4	11,86	1020	17,3
		3	1340	17,83	1533	9,9	15,65	1346	7,9	11,25	968	4,5	12,06	1038	17,6	9,91	852	12,5
TL-ECM 8.2T	MIN	1	1025	14,08	1211	6,5	12,38	1064	5,2	8,94	769	3,0	9,50	817	11,5	7,82	673	8,2

WT: Water temperature
Vdc: Inverter power
Qv: Air flow
Ph: Heating
Qw: Water flow rate
Dp(h): Heating water side pressure drop

Entering air temperature: 20 °C

Model	Speed	Vdc	Qv m ³ /h	WT: 70 / 60 °C			WT: 60 / 50 °C			WT: 50 / 40 °C			WT: 50 / 45 °C			WT: 45 / 40 °C		
				Ph kW	Qw l/h	Dp(h) kPa	Ph kW	Qw l/h	Dp(h) kPa	Ph kW	Qw l/h	Dp(h) kPa	Ph kW	Qw l/h	Dp(h) kPa	Ph kW	Qw l/h	Dp(h) kPa
TL-ECM 7.6T	MAX	10	1905	12,04	1036	24,9	9,07	780	15,3	6,10	525	7,7	7,36	633	37,4	5,89	507	25,5
		7,5	1600	10,98	944	21,1	8,28	712	13,0	5,58	480	6,6	6,71	577	31,7	5,38	463	21,6
	MED	5	1290	9,58	824	16,5	7,23	621	10,2	4,88	420	5,2	5,85	503	24,8	4,69	404	16,9
		3	1040	8,28	712	12,7	6,25	538	7,9	4,23	364	4,0	5,06	435	19,1	4,06	349	13,0
TL-ECM 8.6T	MAX	10	2480	13,89	1195	32,3	10,45	899	19,8	7,02	604	10,0	8,50	731	48,5	6,80	585	32,9
		7,5	2060	12,61	1085	27,1	9,49	817	16,7	6,39	549	8,4	7,71	663	40,7	6,17	531	27,7
	MED	5	1650	11,18	961	21,8	8,42	724	13,4	5,68	488	6,8	6,83	588	32,8	5,48	471	22,3
		3	1340	9,83	845	17,3	7,41	637	10,7	5,00	430	5,4	6,00	516	25,9	4,81	414	17,7
TL-ECM 8.6T	MIN	1	1025	8,20	705	12,5	6,19	532	7,7	4,19	360	3,9	5,01	431	18,7	4,02	346	12,8

WT: Water temperature
Vdc: Inverter power
Qv: Air flow
Ph: Heating
Qw: Water flow rate
Dp(h): Heating water side pressure drop

WATER SIDE PRESSURE DROPS

2 pipe system

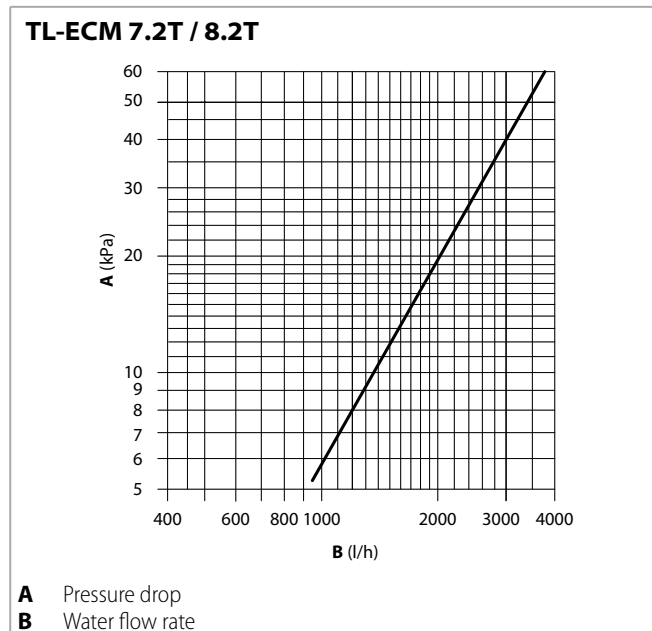

Pressure drop for mean water temperature of 10 °C, for different temperatures multiply the pressure drop figure by the K correction factors in the table.

	Mean water temperature (°C)						
	20	30	40	50	60	70	80
K correction factor	0,94	0,90	0,86	0,82	0,78	0,74	0,70

4 pipe system

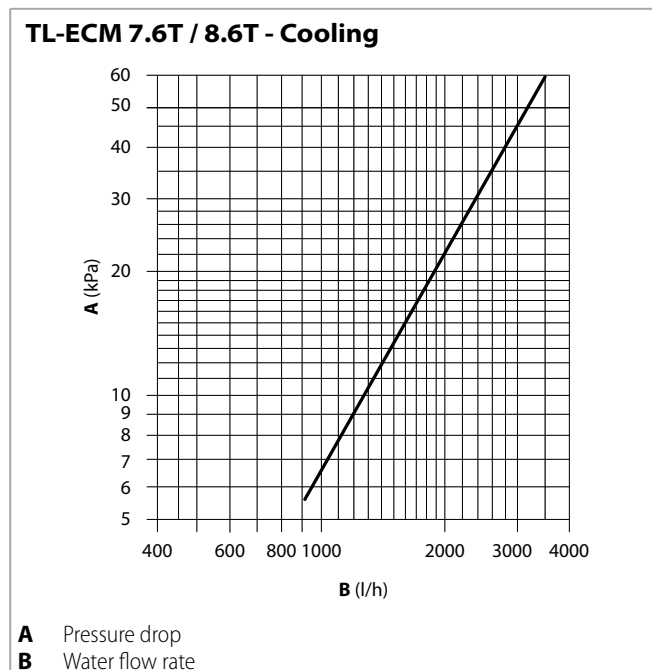

Pressure drop for mean water temperature of 10 °C, for different temperatures multiply the pressure drop figure by the K correction factors in the table.

	Mean water temperature (°C)						
	20	30	40	50	60	70	80
K correction factor	0,94	0,90	0,86	0,82	0,78	0,74	0,70

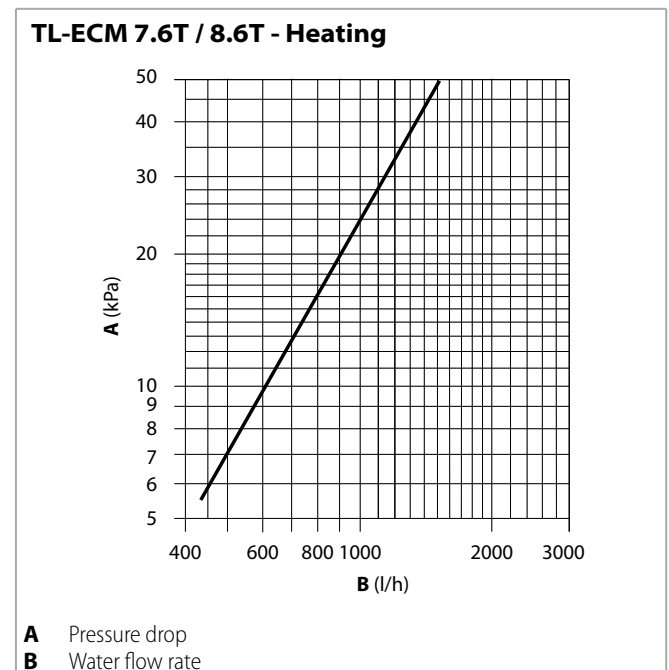

Pressure drop for mean water temperature of 60 °C, for different temperatures multiply the pressure drop figure by the K correction factors in the table.

	Mean water temperature (°C)			
	40	50	70	80
K correction factor	1,12	1,06	0,94	0,88

OPERATING LIMITS

Description		UoM	Value
Water flow	Max. water pressure drop	bars	10
	MIN. entering water temperature	°C	+5
	MAX. entering water temperature mod. 7.2T - 8.2T	°C	+65
	MAX. entering water temperature mod. 7.6T - 8.6T	°C	+80
Ambient air	Suitable relative humidity	%	15÷75
	Minimum temperature	°C	+6
	Maximum temperature	°C	+40
Power supply	Single-phase rated operating voltage	V/Hz	230/50-60
Installation	Maximum height	m	See p. 15

Electric heater operation limits

Description		UoM	Value
Ambient air	Maximum temperature ⁽¹⁾	°C	+25
Power supply	Single-phase rated operating voltage	Vac/Ph/Hz	230/1/50-60
	Rated three phase connection	Vac/Ph/Hz	400/3/50-60
Electrical installation	Connecting wires	N° x mm ²	3 x 2,5

⁽¹⁾ with heating coil
Note: the cooling emission of the units is 95% of the standard emission.



DIMENSION AND WEIGHT

TL-ECM 7.2T / 7.6T / 8.2T / 8.6T

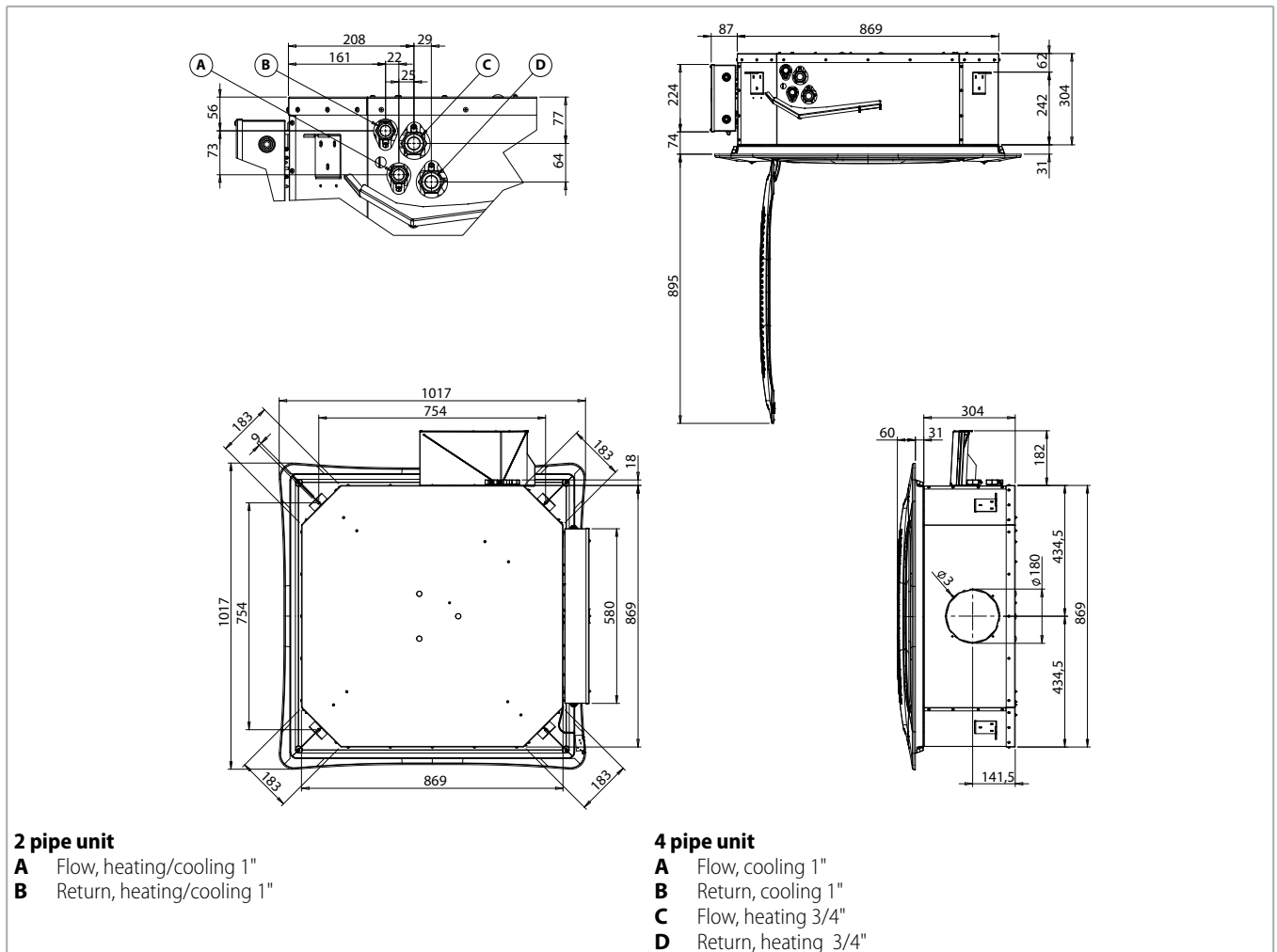

Packed unit

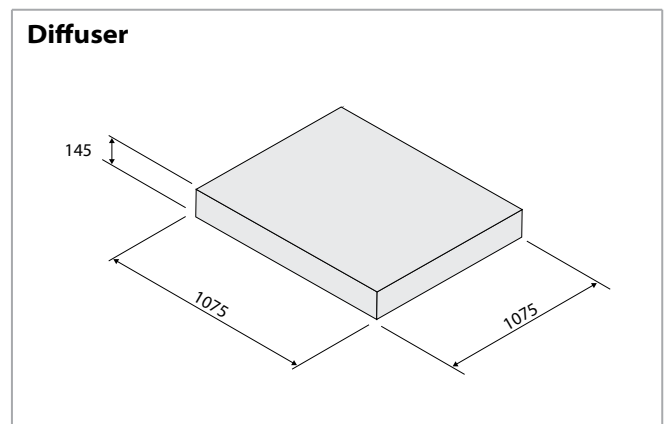
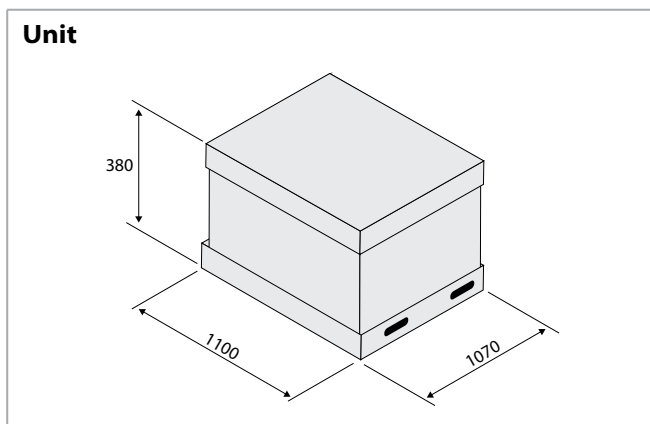

Model	TL-ECM 7.2T	TL-ECM 7.6T	TL-ECM 8.2T	TL-ECM 8.6T
Weight with packaging	kg	52		
Weight without packaging	kg	42		

Model	TL-ECM 7.2T	TL-ECM 7.6T	TL-ECM 8.2T	TL-ECM 8.6T
Weight with packaging	kg	9,4		
Weight without packaging	kg	7,5		

AIR THROW

The air throw indicated in the tables must only be considered the maximum value, as it may change significantly in relation to the dimensions of the room in which the appliance is installed and the positioning of the furniture in the room.

The useful throw L refers to the distance between the unit and the point where the air speed is 0.2 m/sec; if the

louver has a gradient of 40° (recommended in cooling mode), the so-called "coanda" effect will occur, illustrated in the first figure, while at a gradient of 60° (recommended in heating mode), there will be a downwards throw, as illustrated in the second figure.

With adjustable air diffusion louvers at 40°

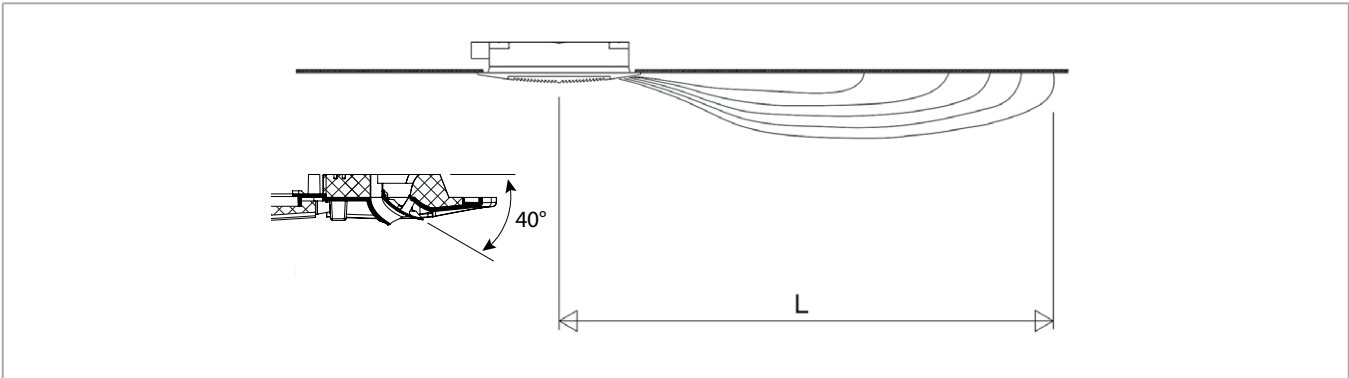

Model		TL-ECM 7.2T / 7.6T			TL-ECM 8.2T / 8.6T		
Speed		Min	Med	Max	Min	Med	Max
L	m	3,5	5,0	6,5	4,0	6,0	7,5

With adjustable air diffusion louvers at 60°

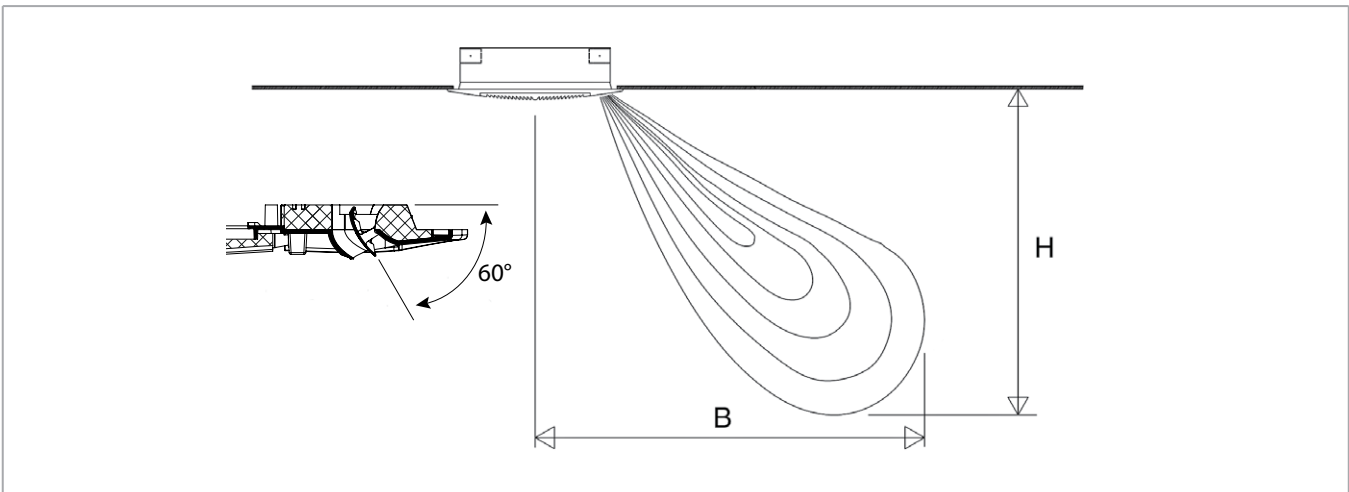

Model		TL-ECM 7.2T / 7.6T			TL-ECM 8.2T / 8.6T		
Speed		Min	Med	Max	Min	Med	Max
H	m	2,8	3,2	3,6	3,0	3,5	4,2
B	m	3,5	4,5	5,5	4,0	5,0	6,5

Note: on heating it must be paid attention to rooms where the floor temperature is particularly low (for example less than 5 °C). In this situation the floor can cool the lower layer of air to a level that stops the uniform diffusion of the hot air coming from the unit, decreasing the throw figures shown in the table.

ACCESSORIES

Air distribution connection

Model	Code
CDA 800	9079233

Two air outlets are provided on the side of the unit for connection to separate supply air outlets. The total air flow does not change.

The air flow at high speed depending on the air duct pressure drop is shown in the tables below.

Note: all air ducts must be insulated in order to avoid condensation.

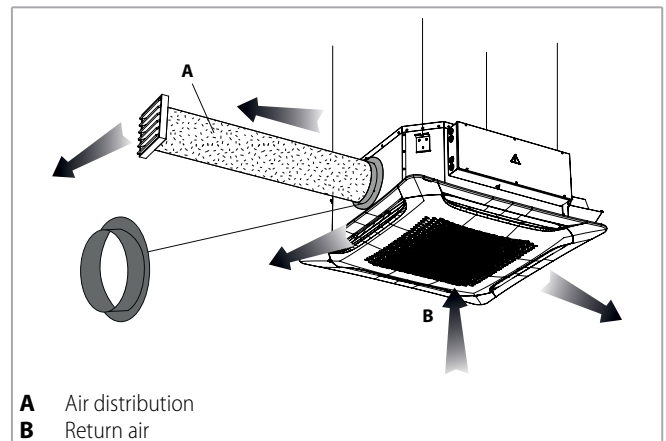
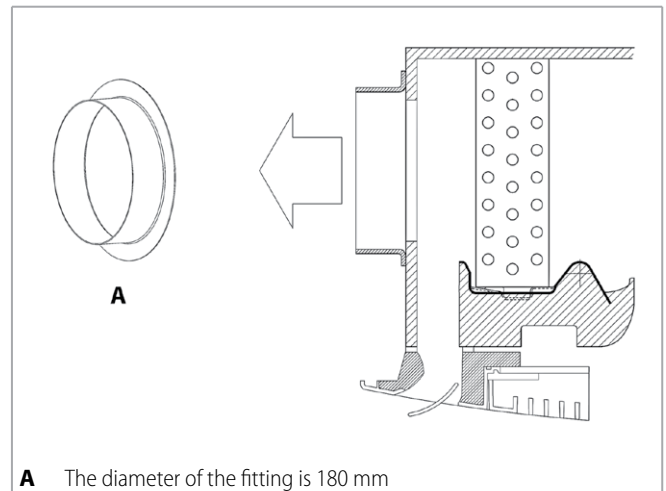
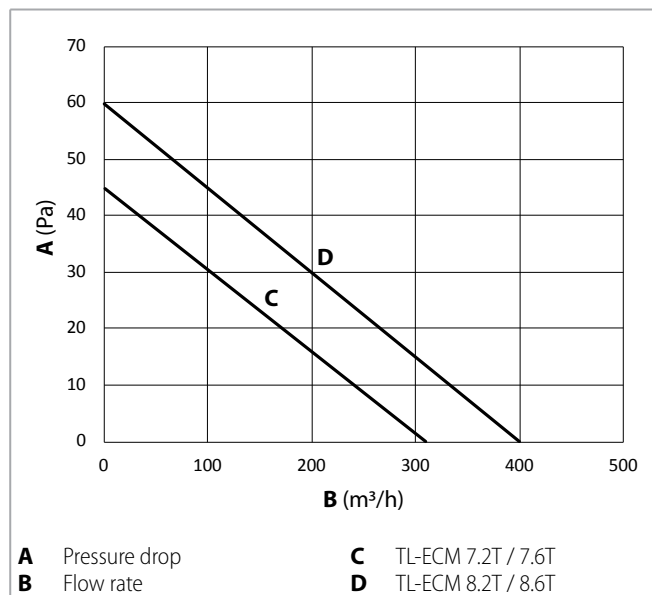

Fresh air kit

Model	Code
PRT 900	907923JUMBO

This is used to introduce fresh air into the environment directly through the diffuser.

The kit includes a flow separator to be fitted inside the cassette, and a circular fitting for connection to the flexible system ducting.

The flow of air is sent directly to just one of the outlet louvers, without passing through the coil. The air flow of fresh air introduced into the environment depends on the inlet static pressure.

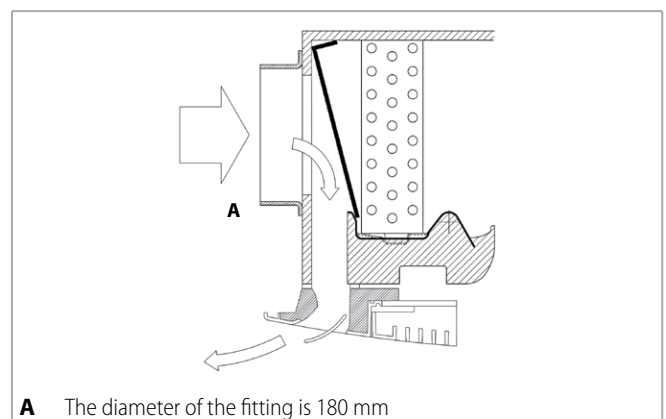

Flow rate	m³/h	160	200	300	400	500
Static pressure	Pa	3	8	15	25	36

ON-OFF valves with thermoelectric actuator

Valves for ON/OFF operation, with ball valve.

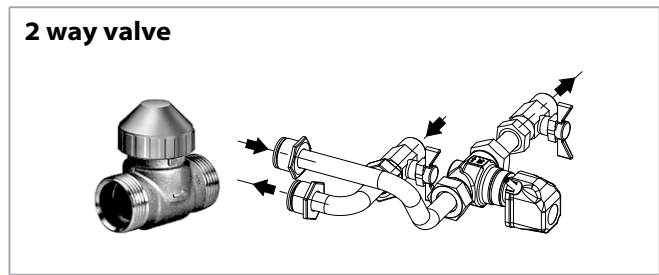
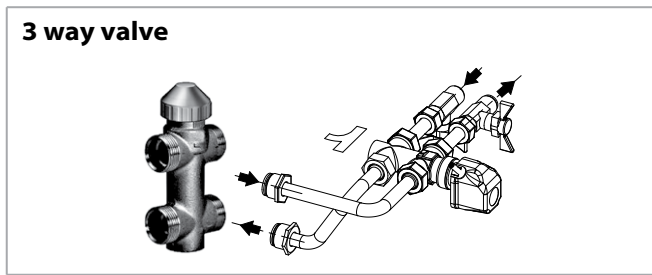

Valve for ON-OFF operation, with simplified kit

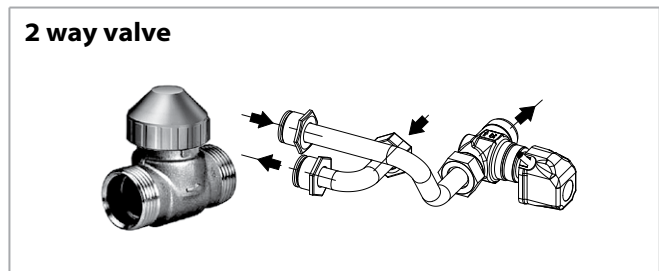
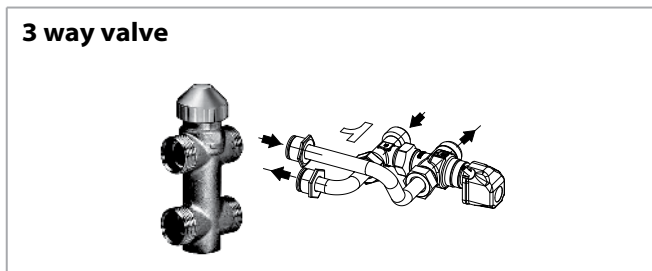

Technical features

Model	2 way valves			3 way valves			Ball valve
	Kvs	Dp max	valve Ø	Kvs	Dp max	valve Ø	Ø
TL-ECM 7.2T/8.2T/7.6T/8.6 ⁽¹⁾	5,2	60	1"	4,5	50	1"	1"
TL-ECM 7.2T/8.2T/7.6T/8.6T ⁽²⁾	2,8	50	3/4"	2,5	50	3/4"	3/4"

- ⁽¹⁾ Main coil
- ⁽²⁾ Additional coil

Technical data

Description	UoM	Value
Max. working pressure	bars	16
Max. ambient temperature	°C	50
Max. water temperature	°C	110
Power supply	V-Hz	230-50/60
Rating	VA	3
Protection		IP 43
Travel time	min	ca. 3
Max. glycol content of water	%	50

Valve set, 2 or 3 ways, ON-OFF, with thermoelectric actuator.
The set includes connection pipes.

Water side pressure drop

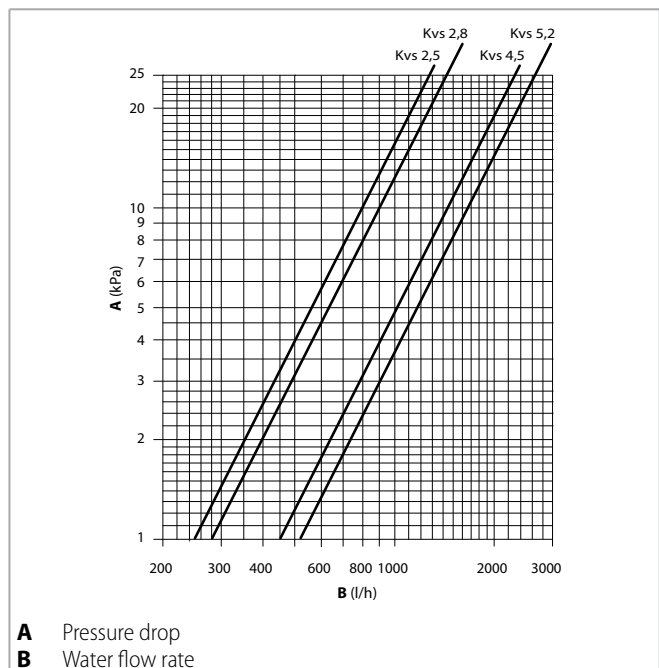

TL-ECM VERSION

For this cassette configuration, the 1-10 Vdc signal, which controls the inverter, must be supplied by a controller with the following signal specifications:

Fan drive signal

- Fan OFF = 0 Vdc
- Fan ON > 1 Vdc
- Max. speed = 10 Vdc

Blac-ECM Inverter board

- 0÷10 Vdc Circuit Input Impedance Value= 68kOhm

Power supply

- 230Vac 1Ph 50Hz

CONTROLS FOR TL-ECM UNITS

All the units of the **TopLine ECM 7-8** range can be supplied with a wide range of controls that allows managing one single unit or several units (with the use of the power units).

The room temperature can be controlled through electronic room thermostats, with different solutions according to every ambient conditions.

The WM-AU, T-MB and WM-S-ECM electronic thermostats control the room temperature precisely and are suitable when the user wants to set the fan speed.

Note: all the controls are described in detail in the "Fan Coil Control Range literature".

(*) To be used with UPM-AU or UP-AU only

WM-AU control (*)



230V 50-60Hz

T-MB control (*)



230V 50-60Hz

UPM-AU / UP-AU power unit



230V 50-60Hz

WM-S-ECM control



230V 50Hz

TL-ECM-MB VERSION

The MB electronic board, to be mounted on the **TL-ECM-MB** and **TL-ECM-MB-E** versions, is set to carry out different functions and adjustment modes, in order to meet the installation requirements.

The Dip Switches on the board have to be set to carry out different functions:

- 2/4 pipe unit
- electronic room thermostat for fan control (ON-OFF)
- electronic room thermostat for valve control (ON-OFF) (the fan keeps working)
- simultaneous thermostatic control of the valves and fan
- fan operation control depending on the coil temperature (cut-out T3 probe fitted), which can be activated only in heating mode or heating and cooling mode
- automatic switch of the operating mode by means of T2 water probe (optional) applied on the 2 pipe system

- seasonal switch by means of remote contact
- ON/OFF of the fan coil by means of the remote contact (window or clock contact)
- electric heater control

By activating the cut-out T3 probe function, the fan is stopped in winter when the coil temperature is lower than 32 °C and started when the temperature reaches 36 °C. In summer mode, the fan stops when inside the coil exceeds 22 °C and starts when it drops below 18 °C. The following connections are located on the power board:

- receiver for infra-red remote control
- T-MB wall control
- serial connection to manage several fan coil units in Master/Slave configuration or to create a supervisory network.

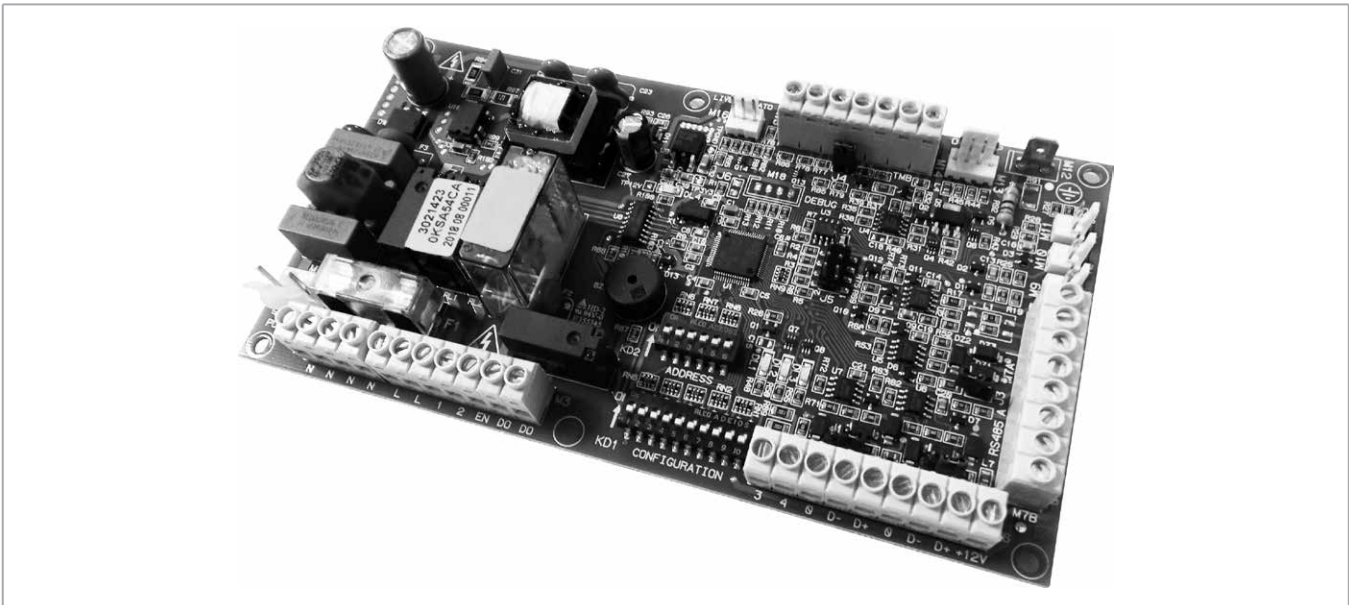

CONTROLS FOR TL-ECM-MB UNITS

All the units **TopLine ECM 7-8** can be supplied in **MB** version. This version includes a wide range of controls, including the infra-red remote control, which allow managing one single unit or several units by using the Bus communication protocol.

Units can be managed according to the Master/Slave logic (up to 20 units) or by supervisory components. The system consists in a MB board and a series of controls, such as the **T-MB** wall control, the **RT03 infra-red remote control**, the **PSM-DI multifunction control panel** and the **NET** supervisory program.

Note: all the controls are described in detail in the "Fan Coil Control Range literature".

T-MB control



230V 50-60Hz

PSM-DI multifunction control panel

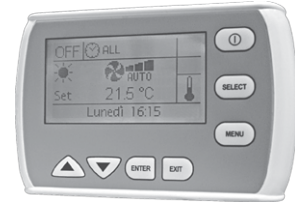

230V 50-60Hz

RT03 remote control



PC and NET screenshot



230V 50-60Hz

The descriptions and illustrations provided in this publication are not binding. **the society** reserves the right, whilst maintaining the essential characteristics of the types described and illustrated, to make, at any time, without the requirement to promptly update this piece of literature, any changes that it considers useful for the purpose of improvement or for any other manufacturing or commercial requirements.

 **ALARKO**



**ALARKO CARRIER
SANAYİ VE TİCARET A.Ş.**

GOSB-Gebze Organize Sanayi Bölgesi
Şahabettin Bilgisu Cad. 41480 Gebze-Kocaeli/TURKEY

Phone : (90)(262) 648 60 00 PBX

Telefax : (90)(262) 648 61 01

web : www.alarko-carrier.com.tr

e-mail : info@alarko-carrier.com.tr