

DFCL/DFCL-ECM

INDICE

DFCL 1 ÷ 5

- Introduction *Page 3*
- Construction features *Page 3*
- Dimensions, weight and water content *Page 4*
- Operating limits *Page 5*
- Technical features *Page 6*
- Main performance and technical characteristics *Page 7*
- Cooling emission tables *Page 10*
- Heating emission tables *Page 14*
- Correction factors tables *Page 16*
- Water side pressure drop *Page 18*
- Accessory air side pressure drop *Page 18*
- Wall electronic controls *Page 32*
- Wall electronic control accessories *Page 34*
- Controls and units **MB version** *Page 59*
- Management system for a network of fan coils *Page 63*
- Accessories (optional) *Page 67*

DFCL 6 ÷ 7

- Introduction *Page 19*
- Construction features *Page 19*
- Dimensions, weight and water content *Page 20*
- Operating limits *Page 21*
- Main performance and technical characteristics *Page 22*
- Cooling emission tables *Page 23*
- Heating emission tables *Page 25*
- Available pressure for **DFCL 64** *Page 26*
- Pressure drop for **DFCL 6** *Page 26*
- Available pressure **DFCL 74** *Page 27*
- Pressure drop **DFCL 7** *Page 27*
- Correction diagram *Page 28*
- Power absorbed (Watt) depending on the variation of the air flow *Page 30*
- Water side pressure drop *Page 31*
- Wall electronic controls *Page 32*
- Wall electronic control accessories *Page 34*
- Controls and units **MB version** *Page 59*
- Management system for a network of fan coils *Page 63*
- Accessories (optional) *Page 67*

DFCL-ECM 1 ÷ 5

- Introduction *Page 35*
- Construction features *Page 35*
- Dimensions, weight and water content *Page 36*
- Operating limits *Page 37*
- Technical features *Page 38*
- Main performance and technical characteristics *Page 39*
- Cooling emission tables *Page 42*
- Heating emission tables *Page 46*
- Correction factors tables *Page 52*
- Water side pressure drop *Page 56*
- Accessory air side pressure drop *Page 56*
- Wall electronic controls *Page 57*
- Wall electronic control accessories *Page 58*
- Controls and units **MB version** *Page 59*
- Management system for a network of fan coils *Page 63*
- Accessories (optional) *Page 67*

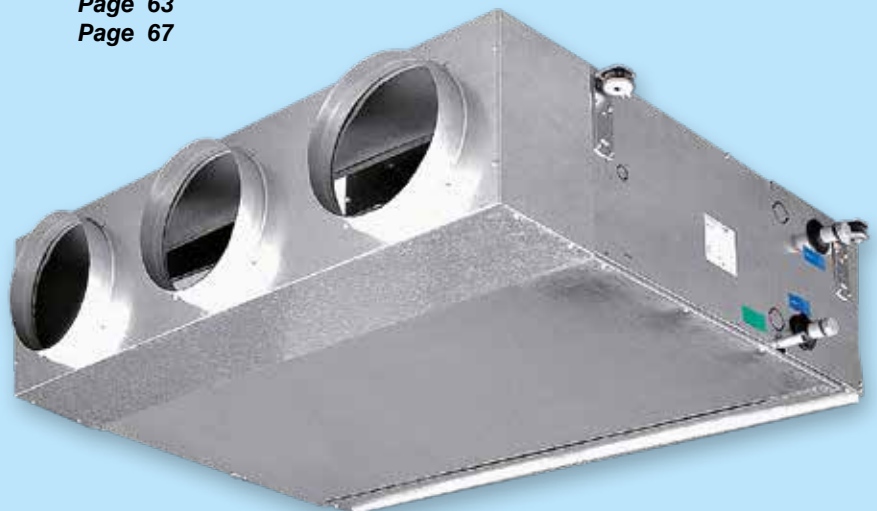

Following many years of experience in the field of heating and air conditioning, we have developed a range of **DFCL** fan coils for concealed installation and connection to a duct system.

Sizes 1÷5 supply a consistent air flow with static pressure up to 160 Pa to fit most conditions, with the combination of either 3 or 4 row heating coils and 2 or 4 pipe configurations with additional heating coil.

The fan assembly has 5 speeds.

Compliant with Regulation (EU) No. 327/2011

Construction features

CASING

It is made with 1,0 mm galvanized steel for sizes 1-2-3 and with 1,2 mm galvanized steel for sizes 4-5, insulated with 10 mm polyolefin (PO) foam (class M1).

FAN ASSEMBLY

Consists of quiet centrifugal fans with two impellers and a directly driven single phase, five speed motor, 230V 50Hz, with capacitor, insulation class F.

COIL

It is manufactured from drawn copper tube and the aluminium fins are mechanically bonded onto the tube by an expansion process.

The **DFCL** range (sizes 1÷5) is available with the combination of either 3 or 4 row coils with the possibility to add a 1 or 2 row coil (3+1, 4+1, 3+2, 4+2 versions for 4 pipe systems).

The connections are on the left hand side looking from the air inlet of the unit (see picture and drawing to the next page). On request the connections can be moved to the other side.

The heat exchanger is not suitable for use in corrosive atmosphere or in environments where aluminium may be subject to corrosion.

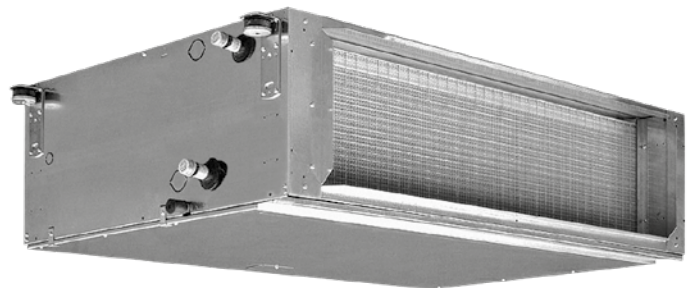

FILTER

The filter is made of polypropylene cellular fabric regenerating filter. The filter frame of galvanized steel is inserted into sliding guides fastened to the internal structure for easy insertion and removal of the filter.

CONDENSATE COLLECTION TRAY

It is made from galvanized steel insulated with 3 mm polyolefin (PO) foam (class M1).

DFCL 1÷5 | Dimensions, weight and water content

Left connections (standard)

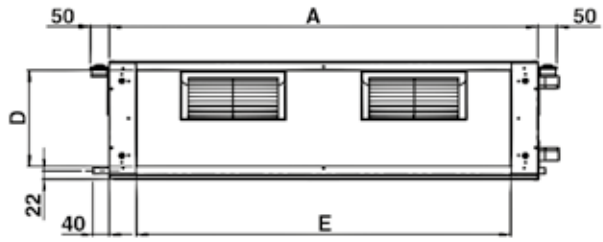
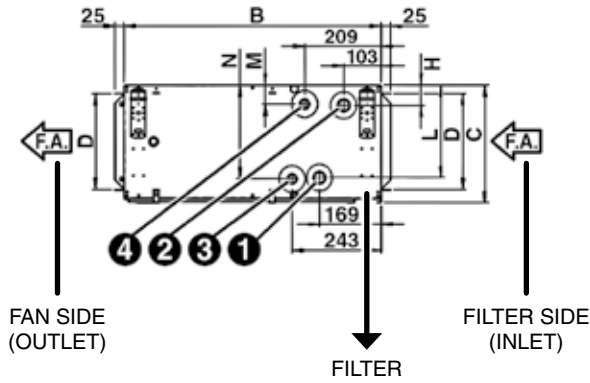

Right connections (on request)

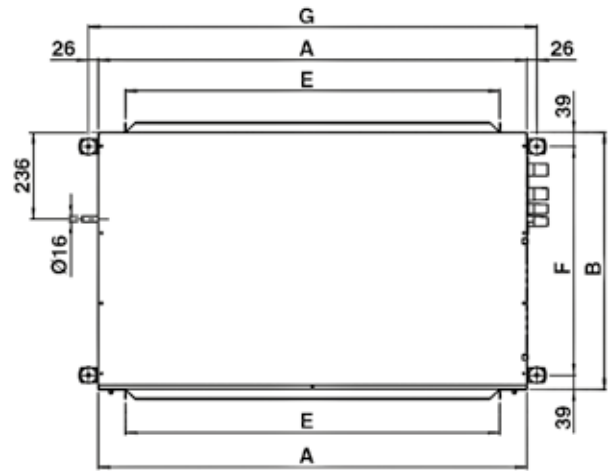
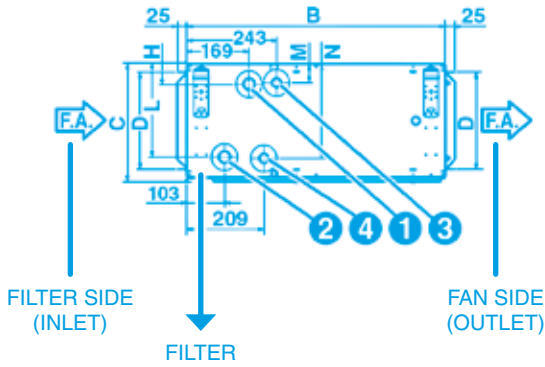

STANDARD



(coil connections on the left looking the air direction)

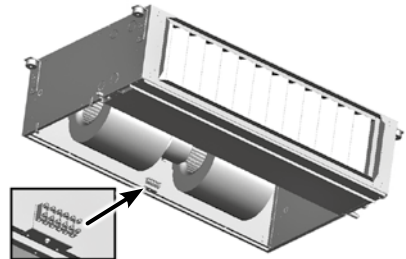

Wiring terminal board

MODEL	Dimensions (mm)											Coil			
	A	B	C	D	E	F	G	H	L	M	N	Main		Additional	
												① IN	② OUT	③ IN	④ OUT
DFCL 1	1133	698	310	255	991	620	1185	54	245	50	249	3/4"	3/4"	3/4"	3/4"
DFCL 2	1133	698	310	255	991	620	1185	54	245	50	249	1"	1"	3/4"	3/4"
DFCL 3	1133	698	360	305	991	620	1185	54	295	50	299	1"	1"	3/4"	3/4"
DFCL 4	1445	853	360	293	1302	775	1497	58	291	54	295	1 1/4"	1 1/4"	1"	1"
DFCL 5	1445	853	435	368	1302	775	1497	58	367	54	370	1 1/4"	1 1/4"	1"	1"

MODEL	Weight without packaging (kg)						Weight with packaging (kg)						Water content (l)			
	3R	3+1R	3+2R	4R	4+1R	4+2R	3R	3+1R	3+2R	4R	4+1R	4+2R	3R	4R	1R	2R
DFCL 1	45	48	50	47	50	51	48	51	53	50	53	54	2,0	2,6	0,9	1,5
DFCL 2	46	50	52	48	51	53	49	53	55	51	54	56	2,9	3,7	1,1	1,8
DFCL 3	54	58	60	56	60	62	57	61	63	59	63	65	3,5	4,6	1,4	2,4
DFCL 4	75	80	83	78	83	86	79	84	87	82	87	90	4,7	6,0	2,0	3,2
DFCL 5	85	90	94	88	94	98	89	94	98	92	98	102	5,7	7,1	2,7	4,1

Water circuit	Maximum water pressure: 1000 kPa (10 bars)	MIN. entering water temperature: + 6 °C
		MAX. entering water temperature: + 80 °C
Air flow	Suitable relative humidity 15-75%	MIN. entering air temperature: + 6 °C
		MAX. entering air temperature: + 40 °C
		MAX. leaving air temperature: + 50 °C
Supply	Single phase 230V 50Hz	

Motor electrical data (max. absorption)

MODEL		DFCL 1	DFCL 2	DFCL 3	DFCL 4	DFCL 5
230/1 50Hz	W	240	340	523	680	885
	A	1,09	1,60	2,45	3,20	4,01

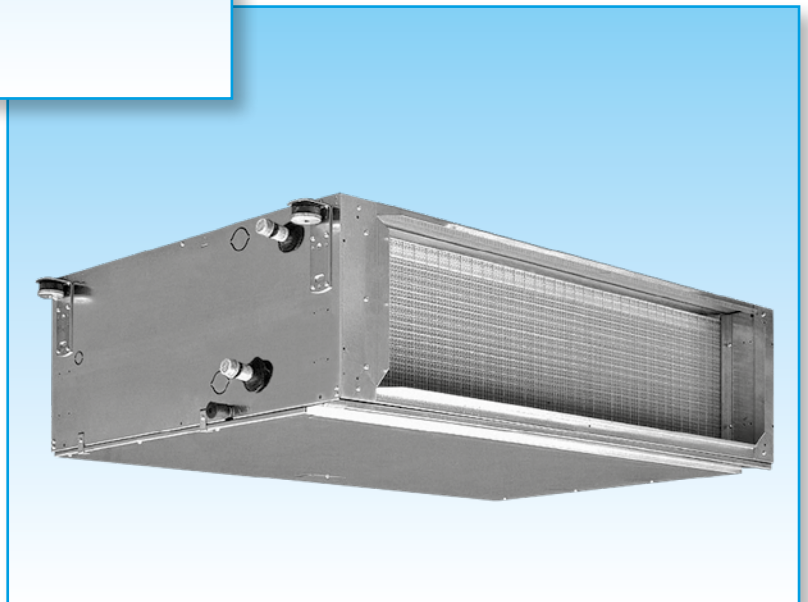
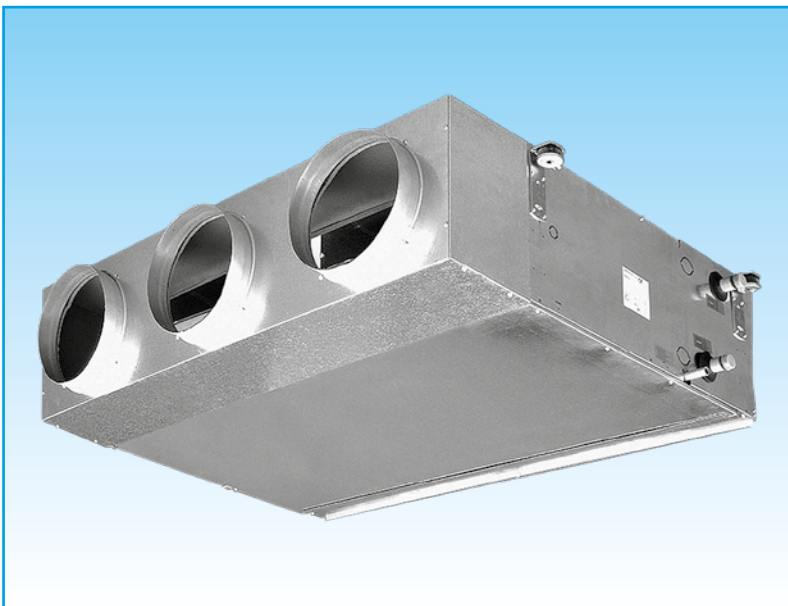

DFCL 1÷5 | Technical features

2 pipe units.

The following standard rating conditions are used:

COOLING (summer mode)

Entering air temperature +27 °C d.b. +19 °C b.u.
Water temperature + 7 °C E.W.T. +12 °C L.W.T.

HEATING (winter mode)

Entering air temperature +20 °C
Water temperature +45 °C E.W.T. +40 °C L.W.T.

MODEL		DFCL 14			DFCL 24			DFCL 34			DFCL 44			DFCL 54		
		1	3	5	1	3	5	1	3	5	1	3	5	1	3	5
Speed																
Air flow	m ³ /h	790	1125	1410	840	1410	1825	1710	2075	2440	2070	2580	3020	2740	3280	3850
Available pressure	Pa	25	50	75	15	50	80	30	50	70	35	50	70	35	50	70
Cooling total emission	kW	4,17	5,21	5,92	4,99	7,01	8,15	8,71	9,76	10,71	10,90	12,40	13,60	14,54	16,19	17,76
Cooling sensible emission	kW	3,25	4,26	5,03	3,66	5,48	6,62	6,67	7,68	8,65	8,25	9,70	10,90	11,21	12,80	14,37
Heating	kW	4,98	6,44	7,67	5,57	8,27	10,10	10,20	11,75	13,19	12,79	14,92	16,53	17,67	20,32	22,93
Dp Cooling	kPa	5,1	7,6	9,6	6,9	12,7	16,8	16,0	19,8	23,4	13,9	17,7	20,9	13,3	16,3	19,4
Dp Heating	kPa	5,2	8,2	11,3	6,2	17,0	18,3	15,6	23,0	24,8	13,4	17,7	21,3	14,2	18,3	22,8
Fan	W	115	155	185	170	230	285	350	420	470	390	490	570	500	617	760
Sound power level outlet	dB(A)	44	52	58	44	56	61	57	62	65	59	63	66	63	67	70
Sound power level inlet + radiated	dB(A)	47	55	60	47	59	64	60	64	67	61	65	68	65	69	72
Sound pressure level outlet (*)	dB(A)	35	43	49	35	47	52	48	53	56	50	54	57	54	58	61
Sound pressure level inlet + radiated (*)	dB(A)	38	46	51	38	50	55	51	55	58	52	56	59	56	60	63
Plenum Code		9034200			9034200			9034220			9034230			9034240		

4 pipe units.

The following standard rating conditions are used:

COOLING (summer mode)

Entering air temperature +27 °C d.b. +19 °C b.u.
Water temperature + 7 °C E.W.T. +12 °C L.W.T.

HEATING (winter mode)

Entering air temperature +20 °C
Water temperature +65 °C E.W.T. +55 °C L.W.T.

MODEL		DFCL 14+1			DFCL 24+1			DFCL 34+1			DFCL 44+1			DFCL 54+1		
		1	3	5	1	3	5	1	3	5	1	3	5	1	3	5
Speed																
Air flow	m ³ /h	770	1090	1350	840	1390	1775	1680	2045	2390	2055	2545	2960	2700	3245	3800
Available pressure	Pa	25	50	75	15	50	80	30	50	70	35	50	70	35	50	70
Cooling total emission	kW	4,09	5,11	5,79	4,99	6,96	8,03	8,61	9,67	10,58	10,85	12,34	13,46	13,75	15,31	16,73
Cooling sensible emission	kW	3,18	4,16	4,87	3,66	5,42	6,49	6,58	7,60	8,51	8,21	9,61	10,72	10,62	12,13	13,56
Heating	kW	3,49	4,29	4,81	4,09	5,53	6,30	6,70	7,44	8,08	8,95	9,95	10,60	11,34	12,55	13,64
Dp Cooling	kPa	4,9	7,3	9,2	6,9	12,5	16,3	15,7	19,4	22,9	13,8	17,4	20,5	12,0	14,7	17,4
Dp Heating	kPa	9,8	14,2	17,5	12,0	20,8	26,3	12,9	15,6	18,1	24,6	29,9	33,9	27,4	32,9	38,4
Fan	W	115	155	185	170	230	285	350	420	470	390	490	570	500	617	760
Sound power level outlet	dB(A)	44	52	58	44	56	61	57	62	65	59	63	66	63	67	70
Sound power level inlet + radiated	dB(A)	47	55	60	47	59	64	60	64	67	61	65	68	65	69	72
Sound pressure level outlet (*)	dB(A)	35	43	49	35	47	52	48	53	56	50	54	57	54	58	61
Sound pressure level inlet + radiated (*)	dB(A)	38	46	51	38	50	55	51	55	58	52	56	59	56	60	63
Plenum Code		9034200			9034200			9034220			9034230			9034240		

(*) = The sound pressure levels are 9 dB(A) lower than the sound power levels and apply to the reverberant field of a 100 m³ room and a reverberation time of 0.5 sec.

2 pipe units.

The following standard rating conditions are used:

COOLING (summer mode)

Entering air temperature +27 °C d.b. +19 °C b.u.
 Water temperature + 7 °C E.W.T. +12 °C L.W.T.

HEATING (winter mode)

Entering air temperature +20 °C
 Water temperature +60 °C E.W.T. +50 °C L.W.T.

AVAILABLE PRESSURE: 0 Pa

DFCL UNITS WITH 3 ROW COIL

MODEL		DFCL 13					DFCL 23					DFCL 33				
		1	2	3	4	5	1	2	3	4	5	1	2	3	4	5
Speed																
Air flow	m³/h	995	1140	1340	1640	1925	855	1165	1550	2060	2510	1815	2080	2300	2590	2790
Cooling total emission	kW	4,05	4,37	4,78	5,32	5,78	4,32	5,21	6,14	7,17	7,90	7,43	8,00	8,44	9,00	9,36
Cooling sensible emission	kW	3,42	3,77	4,24	4,90	5,49	3,29	4,13	5,08	6,23	7,12	6,02	6,62	7,10	7,73	8,16
Heating	kW	7,91	8,71	9,73	11,13	12,33	7,75	9,74	11,92	14,45	16,44	14,27	15,69	16,80	18,19	19,10
Dp Cooling	kPa	7,0	8,1	9,6	11,6	13,7	8,7	12,4	16,9	22,5	27,4	18,7	21,5	23,8	26,8	28,8
Dp Heating	kPa	4,8	5,8	7,1	9,1	11,0	5,1	7,8	11,4	16,4	20,9	12,3	14,6	16,6	19,3	21,1
Fan	W	136	154	175	210	240	180	225	273	320	340	390	430	470	509	523
Sound power Lw	dB(A)	46	49	52	55	59	47	53	57	60	64	58	60	62	64	66
Sound pressure (*)	dB(A)	37	40	43	46	50	38	44	48	51	55	49	51	53	55	57

MODEL		DFCL 43					DFCL 53				
		1	2	3	4	5	1	2	3	4	5
Speed											
Air flow	m³/h	2265	2585	2855	3130	3400	2905	3275	3540	3975	4400
Cooling total emission	kW	9,63	10,34	10,91	11,46	11,91	12,67	13,51	14,07	14,99	15,79
Cooling sensible emission	kW	7,70	8,44	9,05	9,64	10,16	10,31	11,22	11,82	12,85	13,78
Heating	kW	18,06	19,82	21,21	22,56	23,85	23,64	25,71	27,14	29,35	31,42
Dp Cooling	kPa	18,4	21,2	23,5	25,7	28,0	17,2	19,6	21,2	23,9	26,5
Dp Heating	kPa	9,2	11,0	12,5	14,0	15,5	10,9	12,7	14,1	16,3	18,4
Fan	W	445	505	550	600	680	541	622	703	782	885
Sound power Lw	dB(A)	60	62	65	67	69	64	67	69	71	75
Sound pressure (*)	dB(A)	51	53	56	58	60	55	58	60	62	66

DFCL UNITS WITH 4 ROW COIL

MODEL		DFCL 14					DFCL 24					DFCL 34				
		1	2	3	4	5	1	2	3	4	5	1	2	3	4	5
Speed																
Air flow	m³/h	940	1115	1315	1575	1835	855	1160	1535	2005	2360	1795	2060	2265	2550	2745
Cooling total emission	kW	4,67	5,18	5,71	6,32	6,84	5,04	6,18	7,36	8,59	9,39	8,94	9,71	10,24	10,96	11,43
Cooling sensible emission	kW	3,72	4,23	4,79	5,47	6,09	3,70	4,70	5,82	7,08	7,95	6,90	7,63	8,17	8,91	9,40
Heating	kW	8,76	9,95	11,22	12,77	14,20	8,77	11,13	13,76	16,69	18,71	16,43	18,20	19,50	21,22	22,36
Dp Cooling	kPa	6,0	7,3	8,8	10,6	12,4	6,7	9,8	13,5	18,1	21,4	16,3	19,0	21,0	23,9	25,8
Dp Heating	kPa	3,9	4,9	6,1	7,8	9,5	3,7	5,8	8,6	12,3	15,2	9,9	12,0	13,7	16,1	17,7
Fan	W	130	151	173	204	232	180	222	268	320	340	380	426	464	505	520
Sound power Lw	dB(A)	46	49	52	55	59	47	53	57	60	64	58	60	62	64	66
Sound pressure (*)	dB(A)	37	40	43	46	50	38	44	48	51	55	49	51	53	55	57

MODEL		DFCL 44					DFCL 54				
		1	2	3	4	5	1	2	3	4	5
Speed											
Air flow	m³/h	2245	2560	2820	3085	3340	2885	3240	3505	3920	4330
Cooling total emission	kW	11,47	12,40	13,12	13,81	14,38	14,99	16,07	16,80	17,95	18,93
Cooling sensible emission	kW	8,79	9,67	10,38	11,07	11,68	11,63	12,68	13,41	14,57	15,63
Heating	kW	20,86	23,02	24,69	26,36	27,90	27,08	29,56	31,31	33,96	36,49
Dp Cooling	kPa	14,6	16,9	18,8	20,8	22,6	13,5	15,4	16,8	19,0	21,2
Dp Heating	kPa	8,7	10,5	12,0	13,6	15,1	8,0	9,5	10,6	12,3	14,0
Fan	W	445	505	550	600	680	536	612	689	766	868
Sound power Lw	dB(A)	60	62	65	67	69	64	67	69	71	75
Sound pressure (*)	dB(A)	51	53	56	58	60	55	58	60	62	66

(*) = The sound pressure levels are 9 dB(A) lower than the sound power levels and apply to the reverberant field of a 100 m³ room and a reverberation time of 0.5 sec.

DFCL 1÷5 | Main performance and technical characteristics

4 pipe units.

The following standard rating conditions are used:

COOLING (summer mode)

Entering air temperature +27 °C d.b. +19 °C b.u.
Water temperature + 7 °C E.W.T. +12 °C L.W.T.

HEATING (winter mode)

Entering air temperature +20 °C
Water temperature +70 °C E.W.T. +60 °C L.W.T.

AVAILABLE PRESSURE: 0 Pa

DFCL UNITS WITH 3+1 ROW COIL

MODEL		DFCL 13+1					DFCL 23+1					DFCL 33+1				
		1	2	3	4	5	1	2	3	4	5	1	2	3	4	5
Speed																
Air flow	m³/h	940	1115	1315	1575	1835	855	1160	1535	2005	2360	1795	2060	2265	2550	2745
Cooling total emission	kW	3,92	4,32	4,74	5,21	5,64	4,32	5,20	6,11	7,07	7,66	7,38	7,96	8,37	8,92	9,30
Cooling sensible emission	kW	3,28	3,71	4,18	4,76	5,30	3,29	4,12	5,05	6,11	6,83	5,97	6,58	7,03	7,64	8,07
Heating	kW	4,58	5,04	5,51	6,07	6,58	4,78	5,79	6,76	7,78	8,44	8,07	8,69	9,12	9,71	10,08
Dp Cooling	kPa	6,6	7,9	9,4	11,3	13,2	8,7	12,4	16,8	22,0	25,8	18,4	21,2	23,5	26,4	28,4
Dp Heating	kPa	13,7	16,4	19,2	23,0	26,5	15,9	22,4	29,8	38,6	44,8	18,4	21,0	23,0	25,7	27,5
Fan	W	130	151	173	204	232	180	222	268	320	340	380	426	464	505	520
Sound power Lw	dB(A)	46	49	52	55	59	47	53	57	60	64	58	60	62	64	66
Sound pressure (*)	dB(A)	37	40	43	46	50	38	44	48	51	55	49	51	53	55	57

MODEL		DFCL 43+1					DFCL 53+1				
		1	2	3	4	5	1	2	3	4	5
Speed											
Air flow	m³/h	2245	2560	2820	3085	3340	2885	3240	3505	3920	4330
Cooling total emission	kW	9,58	10,29	10,84	11,36	11,80	12,61	13,46	14,01	14,88	15,63
Cooling sensible emission	kW	7,65	8,39	8,97	9,54	10,04	10,26	11,15	11,76	12,73	13,62
Heating	kW	10,53	11,32	11,93	12,50	13,04	13,42	14,30	14,92	15,85	16,73
Dp Cooling	kPa	18,3	21,0	23,2	25,4	27,5	17,1	19,3	21,0	23,5	26,1
Dp Heating	kPa	32,4	37,0	40,8	44,4	47,8	30,0	33,6	36,4	40,6	44,6
Fan	W	445	505	550	600	680	536	612	689	766	868
Sound power Lw	dB(A)	60	62	65	67	69	64	67	69	71	75
Sound pressure (*)	dB(A)	51	53	56	58	60	55	58	60	62	66

DFCL UNITS WITH 4+1 ROW COIL

MODEL		DFCL 14+1					DFCL 24+1					DFCL 34+1				
		1	2	3	4	5	1	2	3	4	5	1	2	3	4	5
Speed																
Air flow	m³/h	910	1090	1290	1530	1775	850	1155	1520	1965	2285	1780	2040	2235	2510	2700
Cooling total emission	kW	4,57	5,11	5,65	6,22	6,75	5,03	6,17	7,32	8,50	9,23	8,90	9,65	10,17	10,85	11,32
Cooling sensible emission	kW	3,62	4,16	4,72	5,35	5,96	3,69	4,69	5,77	6,97	7,77	6,86	7,58	8,10	8,80	9,29
Heating	kW	4,49	4,98	5,46	5,99	6,47	4,76	5,76	6,73	7,71	8,30	8,03	8,64	9,07	9,64	9,99
Dp Cooling	kPa	5,8	7,1	8,6	10,3	12,0	6,6	9,7	13,4	17,7	20,7	16,1	18,8	20,7	23,5	25,4
Dp Heating	kPa	15,3	18,4	21,8	25,7	29,6	15,7	22,3	29,6	37,7	43,5	18,2	20,8	22,7	25,3	27,1
Fan	W	127	149	170	199	226	176	218	262	310	330	375	422	458	499	515
Sound power Lw	dB(A)	46	49	52	55	59	47	53	57	60	64	58	60	62	64	66
Sound pressure (*)	dB(A)	37	40	43	46	50	38	44	48	51	55	49	51	53	55	57

MODEL		DFCL 44+1					DFCL 54+1				
		1	2	3	4	5	1	2	3	4	5
Speed											
Air flow	m³/h	2225	2535	2790	3055	3295	2865	3210	3475	3875	4265
Cooling total emission	kW	11,42	12,34	13,04	13,74	14,29	14,93	15,98	16,74	17,83	18,80
Cooling sensible emission	kW	8,74	9,61	10,30	11,00	11,58	11,58	12,59	13,34	14,45	15,48
Heating	kW	10,50	11,27	11,86	12,44	12,95	13,37	14,25	14,85	15,77	16,58
Dp Cooling	kPa	14,5	16,7	18,6	20,6	22,3	13,4	15,2	16,7	18,8	20,9
Dp Heating	kPa	32,2	36,7	40,3	43,9	47,2	29,7	33,3	36,1	40,2	44,1
Fan	W	440	500	542	599	670	530	604	678	754	851
Sound power Lw	dB(A)	60	62	65	67	69	64	67	69	71	75
Sound pressure (*)	dB(A)	51	53	56	58	60	55	58	60	62	66

(*) = The sound pressure levels are 9 dB(A) lower than the sound power levels and apply to the reverberant field of a 100 m³ room and a reverberation time of 0.5 sec.

4 pipe units.

The following standard rating conditions are used:

COOLING (summer mode)

Entering air temperature +27 °C d.b. +19 °C b.u.
 Water temperature + 7 °C E.W.T. +12 °C L.W.T.

HEATING (winter mode)

Entering air temperature +20 °C
 Water temperature +70 °C E.W.T. +60 °C L.W.T.

AVAILABLE PRESSURE: 0 Pa

DFCL UNITS WITH 4+2 ROW COIL

MODEL		DFCL 14+2					DFCL 24+2					DFCL 34+2				
		1	2	3	4	5	1	2	3	4	5	1	2	3	4	5
Speed																
Air flow	m³/h	875	1055	1260	1470	1695	845	1145	1505	1910	2190	1765	2010	2195	2455	2645
Cooling total emission	kW	4,46	5,00	5,57	6,08	6,60	5,01	6,14	7,28	8,36	9,02	8,86	9,57	10,07	10,73	11,20
Cooling sensible emission	kW	3,51	4,05	4,63	5,19	5,78	3,67	4,67	5,74	6,83	7,54	6,82	7,50	7,99	8,67	9,16
Heating	kW	8,56	9,72	10,92	12,06	13,17	9,14	11,35	13,67	15,95	17,37	16,19	17,63	18,66	20,02	20,98
Dp Cooling	kPa	5,5	6,8	8,3	9,9	11,4	6,6	9,6	13,2	17,2	19,8	16,0	18,4	20,3	22,9	24,8
Dp Heating	kPa	13,2	16,7	20,8	24,8	29,3	12,3	18,4	26,1	34,6	40,6	18,0	21,2	23,5	26,8	29,2
Fan	W	124	145	168	193	218	173	212	257	310	330	369	414	449	489	507
Sound power Lw	dB(A)	46	49	52	55	59	47	53	57	60	64	58	60	62	64	66
Sound pressure (*)	dB(A)	37	40	43	46	50	38	44	48	51	55	49	51	53	55	57

MODEL		DFCL 44+2					DFCL 54+2				
		1	2	3	4	5	1	2	3	4	5
Speed											
Air flow	m³/h	2205	2500	2745	3005	3230	2825	3165	3430	3810	4170
Cooling total emission	kW	11,36	12,24	12,92	13,60	14,14	14,83	15,87	16,62	17,64	18,55
Cooling sensible emission	kW	8,69	9,52	10,19	10,87	11,42	11,47	12,47	13,22	14,27	15,22
Heating	kW	20,93	22,77	24,21	25,66	26,87	26,37	28,46	29,97	32,07	33,94
Dp Cooling	kPa	14,3	16,5	18,3	20,2	21,8	13,2	15,0	16,4	18,5	20,4
Dp Heating	kPa	27,2	31,8	35,6	39,6	43,3	27,4	31,6	34,8	39,4	43,7
Fan	W	434	489	528	587	650	521	593	662	737	828
Sound power Lw	dB(A)	60	62	65	67	69	64	67	69	71	75
Sound pressure (*)	dB(A)	51	53	56	58	60	55	58	60	62	66

(*) = The sound pressure levels are 9 dB(A) lower than the sound power levels and apply to the reverberant field of a 100 m³ room and a reverberation time of 0.5 sec.

Cooling emission of 3 row coil

Entering air temperature: 27 °C – R. H.: 50% – AVAILABLE PRESSURE: 0 Pa

			WT: 7/12 °C				WT: 8/13 °C				WT: 10/15 °C				WT: 12/17 °C				
MODEL	Speed		Qv	Pc	Ps	Qw	Dp(c)	Pc	Ps	Qw	Dp(c)	Pc	Ps	Qw	Dp(c)	Pc	Ps	Qw	Dp(c)
			m³/h	kW	kW	l/h	kPa	kW	kW	l/h	kPa	kW	kW	l/h	kPa	kW	kW	l/h	kPa
DFCL 13	5	MAX	1925	6,52	5,47	1122	15,4	5,77	5,32	992	12,7	4,64	4,54	797	8,3	3,66	3,59	630	5,2
	4		1640	5,90	4,84	1015	13,3	5,31	4,76	914	10,9	4,24	4,15	729	7,0	3,33	3,26	572	4,4
	3	MED	1340	5,32	4,22	914	10,9	4,76	4,11	819	8,9	3,77	3,70	649	5,7	2,94	2,88	505	3,5
	2		1140	4,87	3,77	837	9,3	4,36	3,66	749	7,5	3,44	3,37	591	4,8	2,65	2,60	457	2,9
	1	MIN	995	4,51	3,43	776	8,1	4,03	3,32	694	6,5	3,16	3,10	544	4,1	2,43	2,38	418	2,5
DFCL 23	5	MAX	2510	8,89	7,13	1529	30,9	7,99	7,01	1374	25,3	6,42	6,29	1104	16,6	5,07	4,96	871	10,5
	4		2060	8,02	6,23	1379	25,6	7,22	6,11	1241	20,9	5,75	5,64	990	13,5	4,51	4,42	775	8,4
	3	MED	1550	6,90	5,15	1187	19,3	6,19	5,00	1064	15,7	4,88	4,74	840	10,0	3,78	3,70	650	6,1
	2		1165	5,88	4,23	1011	14,3	5,25	4,07	902	11,6	4,11	3,80	707	7,2	3,14	3,08	541	4,3
	1	MIN	855	4,87	3,40	837	10,1	4,35	3,25	748	8,1	3,37	2,97	580	5,0	2,56	2,50	440	2,9
DFCL 33	5	MAX	2790	10,56	8,23	1816	32,6	9,51	8,09	1636	26,7	7,61	7,46	1309	17,4	5,98	5,86	1029	10,9
	4		2590	10,16	7,83	1748	30,5	9,15	7,68	1573	24,9	7,29	7,15	1254	16,1	5,72	5,60	983	10,0
	3	MED	2300	9,56	7,24	1644	27,1	8,59	7,07	1477	22,1	6,82	6,68	1172	14,2	5,32	5,21	915	8,7
	2		2080	9,06	6,76	1558	24,6	8,14	6,59	1400	19,9	6,43	6,26	1107	12,7	5,00	4,90	859	7,8
	1	MIN	1815	8,41	6,18	1447	21,3	7,53	5,98	1295	17,3	5,94	5,64	1021	11,0	4,59	4,50	789	6,6
DFCL 43	5	MAX	3400	13,60	10,43	2340	32,2	12,24	10,23	2105	26,3	9,76	9,57	1679	17,1	7,65	7,50	1316	10,6
	4		3130	13,03	9,87	2240	29,7	11,71	9,65	2014	24,3	9,31	9,12	1601	15,6	7,27	7,13	1251	9,6
	3	MED	2855	12,21	9,10	2100	26,4	10,97	8,87	1887	21,5	8,68	8,43	1493	13,7	6,75	6,61	1161	8,4
	2		2585	11,58	8,53	1991	23,9	10,38	8,28	1786	19,4	8,20	7,83	1410	12,3	6,35	6,22	1092	7,5
	1	MIN	2265	10,68	7,74	1837	20,5	9,56	7,46	1645	16,6	7,52	7,00	1293	10,5	5,79	5,67	995	6,3
DFCL 53	5	MAX	4400	17,85	14,02	3070	30,0	16,02	13,66	2755	24,6	12,75	12,50	2193	15,8	9,97	9,77	1715	9,8
	4		3975	16,90	13,07	2907	27,2	15,17	12,71	2609	22,2	12,04	11,80	2071	14,2	9,37	9,19	1612	8,7
	3	MED	3540	15,88	12,06	2731	24,2	14,24	11,70	2449	19,7	11,25	11,02	1934	12,6	8,71	8,53	1498	7,6
	2		3275	15,22	11,43	2617	22,4	13,64	11,06	2345	18,2	10,75	10,38	1849	11,5	8,29	8,13	1427	6,9
	1	MIN	2905	14,23	10,51	2447	19,7	12,73	10,14	2189	16,0	10,01	9,46	1721	10,1	7,68	7,53	1321	6,0

Cooling emission of 3 row coil

Entering air temperature: 26 °C – R. H.: 50% – AVAILABLE PRESSURE: 0 Pa

			WT: 7/12 °C				WT: 8/13 °C				WT: 10/15 °C				WT: 12/17 °C				
MODEL	Speed		Qv	Pc	Ps	Qw	Dp(c)	Pc	Ps	Qw	Dp(c)	Pc	Ps	Qw	Dp(c)	Pc	Ps	Qw	Dp(c)
			m³/h	kW	kW	l/h	kPa	kW	kW	l/h	kPa	kW	kW	l/h	kPa	kW	kW	l/h	kPa
DFCL 13	5	MAX	1925	5,74	5,30	988	12,6	5,17	5,07	889	10,3	4,13	4,04	710	6,7	3,59	3,52	617	5,0
	4		1640	5,29	4,73	909	10,8	4,74	4,64	815	8,8	3,76	3,69	647	5,6	3,25	3,19	559	4,2
	3	MED	1340	4,74	4,10	816	8,9	4,23	4,00	728	7,1	3,34	3,27	574	4,5	2,80	2,74	481	3,2
	2		1140	4,33	3,65	744	7,5	3,86	3,55	665	6,0	3,02	2,96	520	3,8	2,41	2,37	415	2,5
	1	MIN	995	4,01	3,31	691	6,5	3,56	3,20	613	5,2	2,78	2,73	479	3,2	2,13	2,09	367	2,0
DFCL 23	5	MAX	2510	7,97	6,99	1370	25,3	7,16	6,88	1232	20,6	5,72	5,60	984	13,3	4,66	4,56	801	9,1
	4		2060	7,18	6,09	1234	20,8	6,43	5,96	1106	16,9	5,10	5,00	877	10,8	3,98	3,90	684	6,6
	3	MED	1550	6,15	4,99	1057	15,6	5,48	4,85	943	12,6	4,30	4,22	740	7,9	3,32	3,25	570	4,7
	2		1165	5,22	4,07	898	11,5	4,65	3,92	799	9,2	3,60	3,53	620	5,7	2,74	2,69	472	3,3
	1	MIN	855	4,32	3,24	743	8,1	3,83	3,10	659	6,4	2,95	2,84	507	3,9	2,21	2,17	381	2,2
DFCL 33	5	MAX	2790	9,47	8,06	1629	26,7	8,49	7,91	1461	21,7	6,76	6,63	1163	13,9	5,28	5,18	909	8,5
	4		2590	9,11	7,66	1566	24,8	8,16	7,49	1403	20,1	6,47	6,34	1113	12,8	5,05	4,94	868	7,8
	3	MED	2300	8,55	7,05	1470	22,1	7,65	6,88	1316	17,8	6,03	5,91	1038	11,3	4,68	4,59	805	6,8
	2		2080	8,09	6,57	1391	19,9	7,23	6,40	1244	16,0	5,68	5,56	977	10,1	4,39	4,30	755	6,0
	1	MIN	1815	7,50	5,97	1290	17,3	6,69	5,79	1151	13,9	5,23	5,12	899	8,6	4,02	3,94	691	5,1
DFCL 43	5	MAX	3400	12,18	10,20	2094	26,3	10,91	9,98	1877	21,3	8,67	8,49	1491	13,6	6,75	6,62	1161	8,3
	4		3130	11,66	9,63	2005	24,2	10,44	9,41	1796	19,6	8,25	8,08	1419	12,4	6,41	6,28	1102	7,5
	3	MED	2855	10,91	8,85	1877	21,4	9,76	8,62	1678	17,2	7,67	7,52	1319	10,9	5,93	5,81	1020	6,5
	2		2585	10,34	8,27	1779	19,3	9,23	8,03	1588	15,6	7,23	7,09	1244	9,7	5,57	5,46	958	5,8
	1	MIN	2265	9,51	7,45	1636	16,6	8,48	7,20	1458	13,3	6,61	6,48	1137	8,2	5,06	4,95	869	4,8
DFCL 53	5	MAX	4400	15,96	13,63	2744	24,5	14,29	13,29	2458	19,8	11,30	11,08	1944	12,6	8,79	8,62	1512	8,0
	4		3975	15,12	12,69	2601	22,2	13,52	12,34	2326	17,9	10,64	10,43	1831	11,3	8,23	8,07	1416	6,8
	3	MED	3540	14,18	11,68	2439	19,7	12,64	11,31	2175	15,8	9,92	9,72	1706	9,9	7,64	7,49	1315	5,9
	2		3275	13,58	11,05	2336	18,1	12,09	10,67	2080	14,6	9,47	9,28	1628	9,1	7,27	7,12	1250	5,4
	1	MIN	2905	12,68	10,13	2181	15,9	11,30	9,77	1944	12,8	8,79	8,61	1512	7,9	6,71	6,58	1155	4,6

Note: the power absorption (Watt) at page 16 must be subtracted from the total and sensible cooling emission.

Cooling emission of 3 row coil

Entering air temperature: 25 °C – R. H.: 50% – AVAILABLE PRESSURE: 0 Pa

MODEL	Speed		WT: 7/12 °C					WT: 8/13 °C					WT: 10/15 °C					WT: 12/17 °C				
			Qv	Pc	Ps	Qw	Dp(c)	Pc	Ps	Qw	Dp(c)	Pc	Ps	Qw	Dp(c)	Pc	Ps	Qw	Dp(c)			
			m³/h	kW	kW	l/h	kPa	kW	kW	l/h	kPa	kW	kW	l/h	kPa	kW	kW	l/h	kPa			
DFCL 13	5	MAX	1925	5,15	5,05	886	10,3	4,62	4,53	795	8,3	3,67	3,60	632	5,3	3,22	3,16	554	4,1			
	4		1640	4,72	4,62	813	8,8	4,22	4,14	726	7,1	3,34	3,27	574	4,5	2,92	2,86	502	3,4			
	3	MED	1340	4,23	3,98	727	7,1	3,76	3,69	647	5,7	2,95	2,89	507	3,5	2,57	2,52	442	2,7			
	2		1140	3,85	3,54	663	6,0	3,42	3,35	588	4,8	2,66	2,61	458	2,9	2,31	2,27	398	2,2			
	1	MIN	995	3,56	3,19	612	5,2	3,15	3,09	542	4,1	2,44	2,39	420	2,5	2,12	2,07	364	1,9			
DFCL 23	5	MAX	2510	7,14	6,84	1228	20,6	6,40	6,27	1101	16,7	5,08	4,98	874	10,7	4,43	4,34	761	8,2			
	4		2060	6,42	5,94	1104	16,9	5,73	5,62	986	13,6	4,51	4,42	776	8,6	3,92	3,84	674	6,5			
	3	MED	1550	5,47	4,83	941	12,6	4,86	4,69	836	10,0	3,79	3,71	652	6,2	3,26	3,19	560	4,6			
	2		1165	4,62	3,91	795	9,2	4,09	3,77	704	7,3	3,15	3,09	543	4,4	2,68	2,63	462	3,2			
	1	MIN	855	3,82	3,10	656	6,4	3,36	2,96	579	5,1	2,56	2,51	441	3,0	2,09	2,04	359	2,0			
DFCL 33	5	MAX	2790	8,48	7,88	1458	21,7	7,58	7,42	1303	17,5	5,99	5,87	1030	11,1	5,20	5,09	894	8,4			
	4		2590	8,14	7,47	1399	20,1	7,27	7,12	1250	16,2	5,73	5,62	986	10,2	4,96	4,86	853	7,7			
	3	MED	2300	7,61	6,85	1310	17,8	6,79	6,66	1168	14,3	5,33	5,22	917	8,9	4,60	4,50	790	6,6			
	2		2080	7,20	6,38	1239	16,0	6,41	6,20	1103	12,8	5,01	4,91	862	7,9	4,31	4,22	741	5,9			
	1	MIN	1815	6,66	5,77	1146	13,9	5,92	5,60	1018	11,1	4,60	4,51	791	6,8	3,93	3,85	677	4,9			
DFCL 43	5	MAX	3400	10,89	9,95	1872	21,3	9,73	9,54	1674	17,2	7,68	7,52	1320	10,8	6,63	6,50	1141	8,1			
	4		3130	10,39	9,37	1788	19,5	9,28	9,09	1596	15,7	7,30	7,15	1255	9,8	6,28	6,16	1081	7,4			
	3	MED	2855	9,70	8,58	1669	17,2	8,64	8,35	1486	13,8	6,77	6,63	1164	8,5	5,81	5,69	999	6,3			
	2		2585	9,19	8,00	1581	15,6	8,17	7,76	1405	12,4	6,37	6,24	1096	7,6	5,45	5,34	937	5,6			
	1	MIN	2265	8,44	7,18	1451	13,3	7,49	6,94	1288	10,5	5,80	5,68	997	6,4	4,93	4,83	848	4,6			
DFCL 53	5	MAX	4400	14,26	13,24	2453	19,8	12,73	12,47	2189	15,9	10,00	9,80	1721	10,0	8,77	8,60	1509	7,7			
	4		3975	13,46	12,28	2316	17,8	12,00	11,76	2064	14,3	9,40	9,21	1616	8,9	8,22	8,06	1414	6,8			
	3	MED	3540	12,64	11,29	2174	15,8	11,21	10,93	1929	12,6	8,74	8,57	1503	7,8	7,63	7,47	1312	5,9			
	2		3275	12,06	10,65	2074	14,6	10,70	10,29	1841	11,6	8,33	8,16	1432	7,1	7,24	7,10	1246	5,3			
	1	MIN	2905	11,25	9,74	1935	12,8	9,96	9,38	1713	10,1	7,71	7,56	1326	6,1	6,68	6,55	1149	4,6			

Note: the power absorption (Watt) at page 16 must be subtracted from the total and sensible cooling emission.

LEGEND

- WT = Water temperature Speed = Fan speed
- Pc = Cooling total emission MAX = High speed
- Ps = Cooling sensible emission MED = Medium speed
- Qw = Water flow MIN = Low speed
- Dp(c) = Water pressure drop Qv = Air flow

Cooling emission of 4 row coil

Entering air temperature: 27 °C – R. H.: 50% – AVAILABLE PRESSURE: 0 Pa

MODEL	Speed	Qv m ³ /h	WT: 7/12 °C				WT: 8/13 °C				WT: 10/15 °C				WT: 12/17 °C				
			Pc kW	Ps kW	Qw l/h	Dp(c) kPa	Pc kW	Ps kW	Qw l/h	Dp(c) kPa	Pc kW	Ps kW	Qw l/h	Dp(c) kPa	Pc kW	Ps kW	Qw l/h	Dp(c) kPa	
DFCL 14	5	MAX	1835	7,64	6,10	1313	14,1	6,84	5,92	1177	11,4	5,40	5,29	928	7,3	4,18	4,10	720	4,5
	4		1575	7,03	5,48	1209	12,1	6,28	5,29	1080	9,8	4,94	4,84	849	6,2	3,81	3,73	655	3,7
	3	MED	1315	6,35	4,82	1092	10,1	5,66	4,63	974	8,1	4,43	4,31	762	5,1	3,39	3,32	583	3,0
	2		1115	5,78	4,28	994	8,4	5,15	4,10	885	6,8	4,00	3,77	687	4,2	3,04	2,98	523	2,5
1	MIN	940	5,20	3,78	895	7,0	4,64	3,60	798	5,6	3,59	3,29	617	3,4	2,71	2,65	466	2,0	
DFCL 24	5	MAX	2360	10,49	8,01	1804	24,5	9,41	7,77	1619	19,9	7,44	7,29	1279	12,7	5,76	5,64	991	7,7
	4		2005	9,61	7,16	1652	20,8	8,60	6,91	1479	16,8	6,76	6,46	1163	10,6	5,20	5,10	895	6,4
	3	MED	1535	8,25	5,94	1419	15,6	7,37	5,69	1267	12,6	5,75	5,24	989	7,8	4,38	4,29	753	4,6
	2		1160	6,95	4,85	1195	11,4	6,20	4,61	1067	9,1	4,81	4,19	827	5,6	3,62	3,55	622	3,2
1	MIN	855	5,68	3,85	977	7,8	5,06	3,64	871	6,3	3,90	3,26	672	3,8	2,92	2,86	502	2,2	
DFCL 34	5	MAX	2745	12,86	9,58	2213	29,5	11,53	9,27	1982	24,0	9,09	8,70	1564	15,2	7,02	6,88	1207	9,2
	4		2550	12,35	9,11	2124	27,4	11,06	8,79	1902	22,3	8,71	8,22	1497	14,0	6,71	6,57	1153	8,4
	3	MED	2265	11,57	8,39	1990	24,2	10,34	8,07	1778	19,6	8,11	7,50	1396	12,3	6,22	6,10	1070	7,3
	2		2060	10,95	7,85	1883	21,9	9,79	7,54	1685	17,7	7,65	6,96	1316	11,1	5,85	5,73	1006	6,5
1	MIN	1795	10,10	7,13	1737	18,8	9,03	6,82	1553	15,2	7,03	6,25	1210	9,4	5,34	5,23	918	5,5	
DFCL 44	5	MAX	3340	16,41	12,11	2823	26,5	14,70	11,70	2529	21,4	11,57	10,94	1990	13,6	8,91	8,73	1533	8,1
	4		3085	15,69	11,46	2699	24,3	14,05	11,04	2416	19,7	11,03	10,29	1898	12,4	8,47	8,30	1457	7,4
	3	MED	2820	14,67	10,55	2523	21,5	13,13	10,14	2258	17,3	10,27	9,38	1766	10,8	7,85	7,69	1350	6,4
	2		2560	13,86	9,85	2383	19,3	12,39	9,44	2132	15,6	9,67	8,69	1664	9,7	7,36	7,22	1266	5,7
1	MIN	2245	12,72	8,89	2187	16,4	11,35	8,48	1952	13,2	8,82	7,74	1518	8,2	6,69	6,56	1151	4,8	
DFCL 54	5	MAX	4330	21,34	16,03	3671	24,4	19,12	15,43	3288	19,7	15,01	14,33	2581	12,4	11,53	11,30	1984	7,4
	4		3920	20,19	14,95	3473	22,0	18,06	14,34	3106	17,8	14,14	13,26	2433	11,1	10,82	10,61	1861	6,6
	3	MED	3505	18,94	13,80	3258	19,5	16,92	13,20	2911	15,7	13,20	12,12	2270	9,8	10,06	9,86	1730	5,8
	2		3240	18,06	13,03	3106	17,8	16,13	12,44	2775	14,4	12,58	11,39	2164	9,0	9,54	9,35	1641	5,2
1	MIN	2885	16,85	11,99	2899	15,7	15,03	11,40	2585	12,6	11,71	10,39	2014	7,8	8,83	8,66	1519	4,5	

Cooling emission of 4 row coil

Entering air temperature: 26 °C – R. H.: 50% – AVAILABLE PRESSURE: 0 Pa

MODEL	Speed	Qv m ³ /h	WT: 7/12 °C				WT: 8/13 °C				WT: 10/15 °C				WT: 12/17 °C				
			Pc kW	Ps kW	Qw l/h	Dp(c) kPa	Pc kW	Ps kW	Qw l/h	Dp(c) kPa	Pc kW	Ps kW	Qw l/h	Dp(c) kPa	Pc kW	Ps kW	Qw l/h	Dp(c) kPa	
DFCL 14	5	MAX	1835	6,80	5,90	1170	11,4	6,07	5,73	1044	9,2	4,76	4,67	819	5,8	4,06	3,98	699	4,3
	4		1575	6,27	5,29	1078	9,8	5,56	5,10	957	7,8	4,34	4,25	747	4,9	3,53	3,46	608	3,3
	3	MED	1315	5,64	4,63	970	8,1	5,01	4,45	861	6,5	3,88	3,81	668	4,0	3,00	2,94	516	2,5
	2		1115	5,12	4,10	881	6,7	4,54	3,92	781	5,4	3,50	3,43	601	3,3	2,64	2,59	455	1,9
1	MIN	940	4,61	3,60	793	5,6	4,08	3,43	701	4,4	3,13	3,06	538	2,6	2,35	2,30	404	1,5	
DFCL 24	5	MAX	2360	9,38	7,76	1613	19,9	8,36	7,52	1438	16,0	6,57	6,43	1129	10,0	5,06	4,96	870	6,0
	4		2005	8,55	6,90	1471	16,8	7,62	6,66	1311	13,4	5,94	5,82	1022	8,3	4,55	4,46	782	4,9
	3	MED	1535	7,33	5,69	1261	12,5	6,51	5,45	1120	10,0	5,03	4,93	865	6,1	3,81	3,73	655	3,5
	2		1160	6,17	4,62	1061	9,1	5,46	4,39	939	7,2	4,18	3,99	720	4,3	3,13	3,07	539	2,4
1	MIN	855	5,03	3,65	866	6,2	4,45	3,45	766	4,9	3,39	3,09	583	2,9	2,51	2,46	431	1,6	
DFCL 34	5	MAX	2745	11,47	9,26	1973	24,0	10,22	8,95	1759	19,3	8,01	7,85	1377	12,0	6,15	6,03	1058	7,1
	4		2550	11,01	8,79	1895	22,2	9,82	8,48	1688	17,8	7,66	7,51	1318	11,0	5,87	5,75	1009	6,5
	3	MED	2265	10,29	8,07	1770	19,5	9,16	7,76	1576	15,7	7,12	6,98	1224	9,6	5,42	5,31	932	5,6
	2		2060	9,74	7,54	1676	17,6	8,66	7,23	1490	14,1	6,70	6,57	1153	8,6	5,09	4,99	875	5,0
1	MIN	1795	8,97	6,82	1543	15,1	7,97	6,52	1371	12,1	6,14	5,98	1057	7,3	4,64	4,55	798	4,2	
DFCL 44	5	MAX	3340	14,62	11,68	2514	21,3	13,04	11,28	2243	17,1	10,17	9,96	1749	10,6	7,79	7,63	1339	6,3
	4		3085	13,97	11,03	2403	19,6	12,43	10,62	2138	15,7	9,68	9,49	1665	9,7	7,39	7,24	1271	5,7
	3	MED	2820	13,06	10,13	2246	17,3	11,61	9,73	1996	13,8	9,00	8,82	1548	8,5	6,84	6,70	1176	4,9
	2		2560	12,31	9,43	2118	15,5	10,94	9,03	1881	12,4	8,45	8,28	1454	7,5	6,40	6,27	1100	4,3
1	MIN	2245	11,29	8,49	1942	13,2	10,01	8,09	1722	10,5	7,70	7,40	1325	6,3	5,79	5,68	997	3,6	
DFCL 54	5	MAX	4330	19,04	15,42	3275	19,7	16,94	14,83	2913	15,8	13,19	12,93	2269	9,7	10,08	9,88	1733	5,7
	4		3920	17,97	14,33	3090	17,7	15,99	13,75	2750	14,1	12,41	12,16	2135	8,7	9,43	9,25	1623	5,0
	3	MED	3505	16,83	13,19	2894	15,6	14,95	12,62	2571	12,5	11,55	11,32	1987	7,6	8,75	8,58	1506	4,4
	2		3240	16,06	12,45	2763	14,3	14,26	11,89	2453	11,4	11,00	10,78	1892	6,9	8,29	8,13	1426	4,0
1	MIN	2885	14,95	11,41	2572	12,6	13,25	10,86	2280	10,0	10,18	9,89	1752	6,0	7,65	7,50	1316	3,4	

Note: the power absorption (Watt) at page 16 must be subtracted from the total and sensible cooling emission.

Cooling emission of 4 row coil

Entering air temperature: 25 °C – R. H.: 50% – AVAILABLE PRESSURE: 0 Pa

MODEL	Speed		WT: 7/12 °C				WT: 8/13 °C				WT: 10/15 °C				WT: 12/17 °C				
			Qv	Pc	Ps	Qw	Dp(c)	Pc	Ps	Qw	Dp(c)	Pc	Ps	Qw	Dp(c)	Pc	Ps	Qw	Dp(c)
			m³/h	kW	kW	l/h	kPa	kW	kW	l/h	kPa	kW	kW	l/h	kPa	kW	kW	l/h	kPa
DFCL 14	5	MAX	1835	6,05	5,70	1040	9,2	5,38	5,27	925	7,4	4,20	4,12	722	4,5	3,72	3,64	639	3,5
	4		1575	5,54	5,08	953	7,9	4,92	4,82	846	6,2	3,82	3,74	656	3,8	3,36	3,30	579	2,9
	3	MED	1315	4,99	4,44	859	6,4	4,41	4,27	759	5,1	3,40	3,33	585	3,1	2,98	2,92	512	2,3
	2		1115	4,52	3,91	777	5,4	3,99	3,75	686	4,2	3,05	2,99	525	2,5	2,66	2,61	457	1,9
	1	MIN	940	4,07	3,43	699	4,4	3,57	3,27	614	3,4	2,72	2,67	468	2,0	2,36	2,31	405	1,5
DFCL 24	5	MAX	2360	8,34	7,50	1434	15,9	7,41	7,26	1275	12,8	5,78	5,67	994	7,8	5,05	4,95	869	6,0
	4		2005	7,60	6,64	1306	13,4	6,74	6,41	1159	10,7	5,22	5,11	898	6,5	4,53	4,44	779	4,8
	3	MED	1535	6,48	5,44	1115	10,0	5,73	5,21	985	7,9	4,39	4,30	755	4,7	3,77	3,69	648	3,4
	2		1160	5,44	4,39	935	7,2	4,79	4,18	824	5,7	3,63	3,56	625	3,3	2,98	2,92	512	2,2
	1	MIN	855	4,43	3,45	762	4,9	3,89	3,26	669	3,8	2,93	2,87	504	2,2	2,23	2,18	383	1,3
DFCL 34	5	MAX	2745	10,20	8,93	1755	19,3	9,05	8,63	1557	15,3	7,05	6,90	1212	9,4	6,11	5,98	1050	7,0
	4		2550	9,77	8,45	1680	17,8	8,68	8,16	1493	14,1	6,73	6,59	1157	8,6	5,81	5,70	1000	6,4
	3	MED	2265	9,12	7,74	1568	15,6	8,08	7,45	1390	12,4	6,23	6,11	1072	7,5	5,36	5,25	922	5,5
	2		2060	8,63	7,22	1484	14,1	7,63	6,93	1312	11,1	5,87	5,75	1010	6,7	5,02	4,92	863	4,8
	1	MIN	1795	7,94	6,51	1366	12,0	7,00	6,22	1204	9,5	5,36	5,25	922	5,6	4,44	4,35	764	3,9
DFCL 44	5	MAX	3340	12,99	11,25	2234	17,1	11,53	10,86	1983	13,6	8,94	8,76	1537	8,3	7,72	7,57	1329	6,2
	4		3085	12,41	10,61	2134	15,7	10,98	10,21	1889	12,5	8,49	8,32	1460	7,6	7,32	7,17	1259	5,6
	3	MED	2820	11,56	9,71	1988	13,8	10,22	9,32	1759	10,9	7,87	7,71	1353	6,5	6,74	6,61	1160	4,8
	2		2560	10,89	9,02	1874	12,4	9,63	8,64	1656	9,7	7,38	7,23	1269	5,8	6,23	6,11	1072	4,1
	1	MIN	2245	9,98	8,09	1716	10,5	8,79	7,71	1512	8,2	6,71	6,57	1153	4,9	5,44	5,33	936	3,2
DFCL 54	5	MAX	4330	16,88	14,79	2903	15,8	14,97	14,24	2576	12,5	11,58	11,35	1991	7,6	10,17	9,97	1750	5,8
	4		3920	15,91	13,72	2737	14,2	14,11	13,17	2426	11,2	10,86	10,65	1869	6,7	9,50	9,31	1634	5,1
	3	MED	3505	14,89	12,60	2561	12,5	13,17	12,06	2265	9,9	10,09	9,89	1736	5,9	8,79	8,61	1512	4,4
	2		3240	14,21	11,87	2443	11,4	12,53	11,34	2156	9,0	9,58	9,39	1648	5,3	8,32	8,15	1430	3,9
	1	MIN	2885	13,20	10,85	2271	10,0	11,65	10,34	2003	7,8	8,87	8,69	1525	4,6	7,58	7,43	1304	3,3

Note: the power absorption (Watt) at page 16 must be subtracted from the total and sensible cooling emission.

LEGEND

- WT = Water temperature **Speed** = Fan speed
- Pc = Cooling total emission **MAX** = High speed
- Ps = Cooling sensible emission **MED** = Medium speed
- Qw = Water flow **MIN** = Low speed
- Dp(c) = Water pressure drop **Qv** = Air flow

Heating emission of 3 row coil

Entering air temperature: 20 °C – AVAILABLE PRESSURE: 0 Pa

MODEL	Speed		Qv m³/h	WT: 70/60 °C			WT: 60/50 °C			WT: 55/45 °C			WT: 50/40 °C			WT: 50/45 °C			WT: 45/40 °C		
				Ph	Qw	Dp(c)	Ph	Qw	Dp(c)	Ph	Qw	Dp(c)	Ph	Qw	Dp(c)	Ph	Qw	Dp(c)	Ph	Qw	Dp(c)
				kW	l/h	kPa	kW	l/h	kPa	kW	l/h	kPa	kW	l/h	kPa	kW	l/h	kPa	kW	l/h	kPa
DFCL 13	5	MAX	1925	16,22	1395	17,7	12,33	1060	11,0	10,39	894	8,2	8,44	726	5,7	9,89	1701	27,2	7,98	1372	18,6
	4		1640	14,61	1257	14,6	11,13	957	9,1	9,38	807	6,8	7,64	657	4,7	8,90	1532	22,4	7,18	1236	15,4
	3	MED	1340	12,74	1096	11,3	9,73	836	7,1	8,21	706	5,3	6,69	575	3,7	7,76	1335	17,4	6,27	1079	11,9
	2		1140	11,39	980	9,2	8,71	749	5,8	7,36	633	4,3	6,00	516	3,0	6,94	1193	14,1	5,61	965	9,7
	1	MIN	995	10,34	889	7,7	7,91	681	4,8	6,70	576	3,6	5,48	471	2,5	6,30	1083	11,8	5,09	876	8,1
DFCL 23	5	MAX	2510	21,50	1849	33,1	16,44	1414	20,9	13,91	1196	15,6	11,37	978	10,9	13,10	2253	50,6	10,60	1824	34,9
	4		2060	18,86	1622	26,0	14,45	1243	16,4	12,24	1053	12,3	10,02	862	8,6	11,50	1978	39,8	9,31	1602	27,5
	3	MED	1550	15,51	1334	18,1	11,92	1025	11,4	10,11	870	8,6	8,30	714	6,0	9,45	1625	27,7	7,67	1319	19,2
	2		1165	12,65	1088	12,4	9,74	838	7,8	8,28	712	5,9	6,81	585	4,1	7,70	1324	18,9	6,25	1075	13,1
	1	MIN	855	10,04	863	8,0	7,75	666	5,1	6,60	568	3,9	5,45	468	2,7	6,10	1050	12,3	4,97	854	8,6
DFCL 33	5	MAX	2790	24,90	2142	33,3	19,10	1642	21,1	16,18	1392	15,8	13,27	1141	11,1	15,19	2612	51,2	12,31	2118	35,4
	4		2590	23,71	2039	30,4	18,19	1564	19,3	15,41	1325	14,4	12,63	1087	10,1	14,46	2487	46,7	11,71	2014	32,3
	3	MED	2300	21,89	1882	26,2	16,80	1445	16,6	14,24	1225	12,4	11,68	1005	8,7	13,34	2294	40,1	10,81	1860	27,8
	2		2080	20,41	1755	23,1	15,69	1349	14,6	13,31	1144	11,0	10,93	940	7,7	12,43	2138	35,4	10,08	1735	24,5
	1	MIN	1815	18,55	1596	19,3	14,27	1227	12,3	12,12	1042	9,2	9,97	857	6,5	11,29	1942	29,6	9,17	1578	20,5
DFCL 43	5	MAX	3400	31,44	2704	25,0	24,09	2072	15,8	20,41	1755	11,8	16,69	1436	8,3	19,16	3295	38,4	15,51	2668	26,5
	4		3130	29,75	2558	22,6	22,80	1960	14,3	19,29	1659	10,7	15,82	1360	7,5	18,11	3115	34,6	14,68	2525	23,9
	3	MED	2855	27,34	2351	19,3	20,99	1805	12,2	17,78	1529	9,1	14,58	1254	6,4	16,65	2864	29,6	13,51	2324	20,5
	2		2585	25,56	2198	17,0	19,61	1687	10,8	16,64	1431	8,1	13,66	1174	5,7	15,56	2677	26,1	12,61	2170	18,1
	1	MIN	2265	23,03	1981	14,1	17,70	1522	8,9	15,03	1293	6,7	12,35	1062	4,7	14,01	2410	21,5	11,37	1956	14,9
DFCL 53	5	MAX	4400	41,01	3527	29,2	31,42	2702	18,4	26,61	2288	13,8	21,79	1874	9,7	24,97	4295	44,7	20,23	3480	31,0
	4		3975	38,28	3292	25,7	29,35	2524	16,3	24,88	2140	12,2	20,39	1753	8,5	23,30	4008	39,4	18,88	3248	27,2
	3	MED	3540	35,31	3037	22,2	27,14	2334	14,1	23,01	1979	10,5	18,87	1623	7,4	21,50	3698	34,0	17,45	3002	23,5
	2		3275	33,45	2877	20,1	25,71	2211	12,7	21,82	1876	9,5	17,89	1539	6,7	20,38	3505	30,7	16,52	2842	21,3
	1	MIN	2905	30,72	2642	17,1	23,64	2033	10,9	20,07	1726	8,1	16,49	1418	5,7	18,70	3217	26,2	15,18	2611	18,2

Heating emission of 4 row coil

Entering air temperature: 20 °C – AVAILABLE PRESSURE: 0 Pa

MODEL	Speed		Qv m³/h	WT: 60/50 °C			WT: 55/45 °C			WT: 50/40 °C			WT: 50/45 °C			WT: 45/40 °C		
				Ph	Qw	Dp(c)	Ph	Qw	Dp(c)	Ph	Qw	Dp(c)	Ph	Qw	Dp(c)	Ph	Qw	Dp(c)
				kW	l/h	kPa	kW	l/h	kPa	kW	l/h	kPa	kW	l/h	kPa	kW	l/h	kPa
DFCL 14	5	MAX	1835	14,20	1221	9,5	11,99	1031	7,1	9,77	840	4,9	11,32	1947	23,3	9,15	1574	16,0
	4		1575	12,77	1098	7,8	10,80	929	5,8	8,82	759	4,0	10,16	1747	19,1	8,22	1413	13,1
	3	MED	1315	11,22	965	6,1	9,51	818	4,6	7,78	669	3,2	8,91	1532	15,0	7,22	1241	10,3
	2		1115	9,95	856	4,9	8,44	726	3,7	6,92	595	2,6	7,88	1356	11,9	6,39	1099	8,2
	1	MIN	940	8,76	753	3,9	7,44	640	2,9	6,11	525	2,0	6,91	1189	9,4	5,61	966	6,5
DFCL 24	5	MAX	2360	18,71	1609	15,2	15,88	1366	11,4	13,02	1120	8,0	14,83	2552	36,9	12,03	2070	25,6
	4		2005	16,69	1435	12,3	14,17	1219	9,2	11,65	1002	6,5	13,20	2271	29,8	10,72	1845	20,6
	3	MED	1535	13,76	1183	8,6	11,71	1007	6,4	9,64	829	4,5	10,84	1865	20,7	8,82	1517	14,3
	2		1160	11,13	957	5,8	9,49	816	4,3	7,84	674	3,1	8,75	1505	13,9	7,13	1226	9,6
	1	MIN	855	8,77	754	3,7	7,48	644	2,8	6,20	533	2,0	6,85	1178	8,8	5,60	963	6,1
DFCL 34	5	MAX	2745	22,36	1923	17,7	19,00	1634	13,2	15,62	1343	9,4	17,67	3040	42,7	14,37	2471	29,5
	4		2550	21,22	1825	16,1	18,04	1552	12,0	14,85	1277	8,5	16,77	2884	38,7	13,63	2344	26,8
	3	MED	2265	19,50	1677	13,7	16,60	1427	10,3	13,67	1176	7,2	15,39	2646	32,9	12,51	2151	22,8
	2		2060	18,20	1565	12,0	15,50	1333	9,0	12,78	1099	6,4	14,34	2466	28,9	11,67	2007	20,1
	1	MIN	1795	16,43	1413	9,9	14,00	1204	7,5	11,56	994	5,3	12,93	2223	23,8	10,53	1811	16,6
DFCL 44	5	MAX	3340	28,23	2428	15,4	24,00	2064	11,6	19,75	1699	8,2	22,29	3834	37,3	18,13	3119	25,8
	4		3085	26,67	2293	13,9	22,68	1951	10,4	18,67	1606	7,3	21,05	3620	33,5	17,12	2944	23,2
	3	MED	2820	24,49	2106	11,8	20,84	1792	8,9	17,16	1476	6,3	19,29	3318	28,5	15,70	2700	19,7
	2		2560	22,77	1958	10,4	19,40	1669	7,8	16,01	1377	5,5	17,92	3083	24,9	14,60	2512	17,3
	1	MIN	2245	20,45	1759	8,4	17,43	1499	6,4	14,39	1238	4,5	16,06	2762	20,3	13,09	2251	14,1
DFCL 54	5	MAX	4330	36,49	3138	14,0	30,98	2665	10,5	25,45	2189	7,4	28,84	4960	33,9	23,43	4029	23,5
	4		3920	33,96	2921	12,3	28,86	2482	9,2	23,73	2041	6,5	26,82	4613	29,7	21,80	3750	20,5
	3	MED	3505	31,31	2692	10,6	26,63	2290	7,9	21,91	1884	5,6	24,69	4246	25,4	20,07	3452	17,6
	2		3240	29,56	2542	9,5	25,16	2163	7,1	20,72	1782	5,0	23,27	4002	22,8	18,94	3257	15,8
	1	MIN	2885	27,08	2329	8,0	23,06	1983	6,0	19,03	1637	4,2	21,30	3664	19,3	17,35	2984	13,4

LEGEND WT = Water temperature Ph = Emission Qw = Water flow Dp(c) = Water pressure drop Qv = Air flow Speed = Fan speed MAX = High speed MED = Medium speed MIN = Low speed

Heating emission of 1 row additional coil

Entering air temperature: 20 °C – AVAILABLE PRESSURE: 0 Pa

MODEL	Speed	WT: 80/70 °C						WT: 75/65 °C			WT: 70/60 °C			WT: 65/55 °C			WT: 60/50 °C			WT: 55/45 °C				
		Qv	Ph	Qw	Dp(c)	Ph	Qw	Dp(c)	Ph	Qw	Dp(c)	Ph	Qw	Dp(c)	Ph	Qw	Dp(c)	Ph	Qw	Dp(c)	Ph	Qw	Dp(c)	
		m³/h	kW	l/h	kPa	kW	l/h	kPa	kW	l/h	kPa	kW	l/h	kPa	kW	l/h	kPa	kW	l/h	kPa	kW	l/h	kPa	
DFCL 1	5	MAX	1775	8,05	692	42,7	7,26	624	36,0	6,47	556	29,6	5,67	488	23,8	4,89	420	18,4	4,10	352	13,6			
	4		1530	7,44	640	37,1	6,71	577	31,2	5,99	515	25,7	5,25	452	20,7	4,52	389	16,0	3,80	326	11,8			
	3	MED	1290	6,78	583	31,3	6,12	527	26,4	5,46	470	21,8	4,80	412	17,5	4,13	355	13,6	3,47	298	10,0			
	2		1090	6,18	532	26,4	5,59	480	22,3	4,98	428	18,4	4,38	377	14,8	3,77	324	11,5	3,17	272	8,5			
	1	MIN	910	5,57	479	21,9	5,03	433	18,5	4,49	387	15,3	3,95	340	12,2	3,40	293	9,5	2,86	246	7,1			
DFCL 2	5	MAX	2285	10,33	888	62,2	9,32	802	52,6	8,30	714	43,5	7,31	628	35,0	6,30	542	27,2	5,30	456	20,1			
	4		1965	9,56	822	54,2	8,64	743	45,7	7,71	663	37,7	6,78	583	30,5	5,84	502	23,7	4,91	423	17,6			
	3	MED	1520	8,35	718	42,4	7,53	648	35,8	6,73	579	29,6	5,91	509	23,8	5,11	439	18,6	4,30	370	13,8			
	2		1155	7,14	614	31,9	6,45	555	27,0	5,76	495	22,3	5,07	436	18,0	4,39	377	14,0	3,69	318	10,4			
	1	MIN	850	5,90	507	22,5	5,33	458	19,1	4,76	410	15,7	4,20	361	12,7	3,63	312	9,9	3,06	263	7,4			
DFCL 3	5	MAX	2700	12,44	1070	39,0	11,21	964	32,9	9,99	859	27,1	8,77	754	21,7	7,55	649	16,8	6,33	544	12,4			
	4		2510	11,98	1031	36,4	10,80	929	30,7	9,64	829	25,3	8,45	727	20,3	7,28	626	15,7	6,10	524	11,6			
	3	MED	2235	11,28	970	32,7	10,17	874	27,6	9,07	780	22,7	7,96	685	18,2	6,86	590	14,1	5,75	494	10,4			
	2		2040	10,74	924	29,9	9,68	833	25,2	8,64	743	20,8	7,59	653	16,7	6,53	562	13,0	5,48	472	9,6			
	1	MIN	1780	9,97	857	26,2	9,00	774	22,0	8,03	691	18,2	7,06	607	14,6	6,07	522	11,3	5,10	439	8,4			
DFCL 4	5	MAX	3295	16,17	1391	68,3	14,61	1256	57,9	13,03	1121	47,8	11,48	988	38,6	9,92	853	30,1	8,36	719	22,4			
	4		3055	15,52	1335	63,5	14,02	1206	53,7	12,52	1077	44,5	11,04	949	35,8	9,53	819	27,9	8,03	691	20,8			
	3	MED	2790	14,59	1255	57,0	13,20	1135	48,2	11,80	1015	39,9	10,37	892	32,1	8,97	771	25,1	7,56	650	18,7			
	2		2535	13,86	1192	51,8	12,52	1077	43,8	11,20	963	36,3	9,86	848	29,2	8,52	732	22,8	7,18	617	17,0			
	1	MIN	2225	12,82	1102	44,9	11,57	995	37,9	10,34	890	31,5	9,12	784	25,3	7,88	677	19,8	6,65	572	14,8			
DFCL 5	5	MAX	4265	20,57	1769	63,1	18,57	1597	53,2	16,58	1426	44,1	14,61	1257	35,6	12,62	1086	27,7	10,63	914	20,6			
	4		3875	19,53	1680	57,5	17,66	1519	48,6	15,77	1356	40,2	13,88	1193	32,4	12,00	1032	25,3	10,10	869	18,8			
	3	MED	3475	18,40	1583	51,6	16,65	1432	43,6	14,85	1277	36,1	13,09	1125	29,2	11,31	973	22,7	9,54	820	16,9			
	2		3210	17,63	1516	47,6	15,93	1370	40,2	14,25	1225	33,3	12,54	1078	26,9	10,85	933	20,9	9,14	786	15,6			
	1	MIN	2865	16,56	1424	42,4	14,97	1287	35,9	13,37	1150	29,7	11,78	1013	24,0	10,19	876	18,7	8,59	739	13,9			

Heating emission of 2 row additional coil

Entering air temperature: 20 °C – AVAILABLE PRESSURE: 0 Pa

MODEL	Speed	WT: 65/55 °C			WT: 60/50 °C			WT: 55/45 °C			WT: 50/40 °C			WT: 45/40 °C			WT: 45/35 °C				
		Qv	Ph	Qw	Dp(c)	Ph	Qw	Dp(c)	Ph	Qw	Dp(c)	Ph	Qw	Dp(c)	Ph	Qw	Dp(c)	Ph	Qw	Dp(c)	
		m³/h	kW	l/h	kPa	kW	l/h	kPa	kW	l/h	kPa	kW	l/h	kPa	kW	l/h	kPa	kW	l/h	kPa	
DFCL 1	5	MAX	1695	11,59	997	20,4	10,00	860	15,9	8,41	723	11,7	6,82	586	8,1	6,47	1112	26,7	5,22	449	5,0
	4		1470	10,60	912	17,3	9,17	788	13,4	7,72	664	9,9	6,26	538	6,9	5,92	1018	22,6	4,80	413	4,3
	3	MED	1260	9,62	827	14,4	8,31	715	11,2	7,00	602	8,3	5,69	490	5,8	5,37	924	18,9	4,37	376	3,6
	2		1055	8,57	737	11,6	7,41	637	9,1	6,25	538	6,7	5,09	438	4,7	4,78	822	15,2	3,92	337	2,9
	1	MIN	875	7,55	649	9,2	6,53	562	7,2	5,52	474	5,3	4,50	387	3,7	4,21	724	12,1	3,47	299	2,3
DFCL 2	5	MAX	2190	15,33	1318	32,8	13,27	1141	25,5	11,21	964	19,0	9,14	786	13,3	8,57	1474	43,0	7,07	608	8,4
	4		1910	14,07	1210	28,0	12,18	1048	21,8	10,31	887	16,3	8,41	724	11,4	7,87	1353	36,6	6,52	561	7,2
	3	MED	1505	12,07	1038	21,0	10,47	900	16,5	8,87	763	12,3	7,25	623	8,6	6,74	1160	27,5	5,63	484	5,4
	2		1145	10,03	862	15,0	8,71	749	11,7	7,38	635	8,7	6,05	521	6,1	5,60	964	19,6	4,72	406	3,9
	1	MIN	845	8,09	695	10,0	7,03	605	7,8	5,97	513	5,9	4,91	422	4,1	4,51	776	13,1	3,84	330	2,6
DFCL 3	5	MAX	2645	18,47	1589	20,0	15,97	1373	15,5	13,46	1157	11,6	10,94	941	8,0	10,33	1777	26,2	8,40	722	5,0
	4		2455	17,64	1517	18,4	15,24	1311	14,3	12,86	1106	10,6	10,44	898	7,4	9,85	1694	24,0	8,04	691	4,6
	3	MED	2195	16,43	1413	16,1	14,22	1223	12,5	11,99	1031	9,3	9,76	839	6,5	9,18	1580	21,1	7,51	646	4,0
	2		2010	15,54	1336	14,5	13,44	1156	11,3	11,33	975	8,4	9,24	795	5,8	8,67	1492	19,0	7,12	613	3,7
	1	MIN	1765	14,27	1227	12,4	12,35	1062	9,7	10,44	898	7,2	8,51	731	5,0	7,96	1370	16,2	6,57	565	3,1
DFCL 4	5	MAX	3230	23,95	2060	35,6	20,75	1785	27,8	17,57	1511	20,8	14,37	1236	14,5	13,40	2305	46,6	11,17	960	9,2
	4		3005	22,83	1963	32,5	19,79	1702	25,4	16,76	1441	19,0	13,72	1180	13,3	12,77	2196	42,6	10,66	917	8,5
	3	MED	2745	21,25	1827	28,4	18,46	1587	22,3	15,62	1343	16,7	12,80	1101	11,7	11,88	2044	37,4	9,95	856	7,4
	2		2500	19,95	1716	25,3	17,33	1490	19,8	14,69	1264	14,8	12,04	1035	10,4	11,17	1920	33,3	9,38	807	6,6
	1	MIN	2205	18,19	1565	21,3	15,80	1359	16,7	13,41	1153	12,5	11,01	947	8,8	10,17	1749	28,0	8,57	737	5,6
DFCL 5	5	MAX	4170	29,93	2574	30,4	25,94	2231	23,7	21,94	1886	17,7	17,90	1539	12,4	16,73	2877	39,9	13,85	1192	7,8
	4		3810	28,30	2434	27,4	24,51	2107	21,3	20,74	1784	15,9	16,93	1456	11,2	15,82	2720	35,8	13,13	1129	7,1
	3	MED	3430	26,44	2274	24,2	22,94	1973	18,9	19,42	1670	14,1	15,87	1365	9,8	14,79	2543	31,6	12,31	1059	6,2
	2		3165	25,10	2158	21,9	21,77	1872	17,2	18,43	1585	12,8	15,08	1297	9,0	14,03	2414	28,7	11,71	1007	5,7
	1	MIN	2825	23,30	2004	19,1	20,21	1738	14,9	17,13	1473	11,2	14,02	1205	7,8	13,02	2240	25,0	10,90	938	5,0

LEGEND

WT = Water temperature
Ph = Emission
Qw = Water flow

Dp(c) = Water pressure drop
Qv = Air flow
Speed = Fan speed

Air flow (m³/h)
depending on speed and requested available pressure with 4 row coil

MODEL	Speed		Available pressure (Pa)										
			0	20	40	60	80	100	120	140	160	180	200
DFCL 1	5	MAX	1835	1745	1640	1530	1400	1225	995	–	–	–	–
	4		1575	1480	1390	1290	1175	1020	815	–	–	–	–
	3	MED	1315	1250	1175	1075	940	795	–	–	–	–	–
	2		1115	1025	940	840	740	625	–	–	–	–	–
	1	MIN	940	825	730	645	560	–	–	–	–	–	–
DFCL 2	5	MAX	2360	2240	2120	2000	1860	1700	1480	1150	–	–	–
	4		2005	1920	1835	1735	1620	1480	1275	–	–	–	–
	3	MED	1535	1495	1445	1380	1300	1190	1010	–	–	–	–
	2		1160	1150	1135	1105	1065	1015	925	–	–	–	–
	1	MIN	855	835	815	790	755	700	–	–	–	–	–
DFCL 3	5	MAX	2745	2670	2590	2500	2390	2270	2135	1980	1800	1620	–
	4		2550	2470	2380	2280	2175	2045	1900	1750	1595	1425	–
	3	MED	2265	2200	2120	2040	1945	1840	1720	1590	1440	1280	–
	2		2060	2005	1945	1875	1790	1695	1575	1445	1300	–	–
	1	MIN	1795	1745	1690	1625	1545	1460	1355	1235	1105	–	–
DFCL 4	5	MAX	3340	3250	3150	3040	2900	2760	2610	2440	2225	2000	1780
	4		3085	3005	2920	2820	2700	2575	2405	2225	2025	1800	–
	3	MED	2820	2740	2650	2550	2440	2300	2150	1970	1765	1575	–
	2		2560	2480	2400	2305	2200	2050	1905	1745	1575	–	–
	1	MIN	2245	2175	2100	2020	1925	1800	1670	1525	1400	–	–
DFCL 5	5	MAX	4330	4330	4205	4075	3935	3785	3630	3450	3250	3005	2705
	4		3920	3820	3715	3595	3465	3315	3145	2940	2680	2350	–
	3	MED	3505	3425	3340	3245	3130	3000	2845	2650	2400	2080	–
	2		3240	3140	3040	2930	2810	2675	2530	2350	2130	1850	–
	1	MIN	2885	2805	2715	2610	2495	2350	2175	1965	1710	–	–

Power absorption (Watt)
depending on air flow and available pressure

MODEL	Speed		Available pressure (Pa)										
			0	20	40	60	80	100	120	140	160	180	200
DFCL 1	5	MAX	231	223	213	202	190	174	154	–	–	–	–
	4		204	194	184	174	162	148	130	–	–	–	–
	3	MED	173	167	159	150	137	124	–	–	–	–	–
	2		151	142	134	125	116	106	–	–	–	–	–
	1	MIN	130	118	109	102	95	–	–	–	–	–	–
DFCL 2	5	MAX	380	356	333	312	288	263	232	193	–	–	–
	4		323	304	284	263	240	217	191	–	–	–	–
	3	MED	268	254	239	222	204	184	158	–	–	–	–
	2		221	215	206	191	177	165	151	–	–	–	–
	1	MIN	179	167	158	148	137	126	–	–	–	–	–
DFCL 3	5	MAX	519	510	498	481	460	438	415	393	372	352	–
	4		505	492	473	450	427	400	376	357	340	323	–
	3	MED	464	450	431	411	389	368	349	332	317	301	–
	2		426	413	398	381	362	344	326	310	295	–	–
	1	MIN	380	362	345	330	316	305	294	283	270	–	–
DFCL 4	5	MAX	680	657	627	597	562	532	504	476	447	419	393
	4		600	587	566	541	512	485	453	427	402	378	–
	3	MED	550	527	503	481	459	436	413	389	362	338	–
	2		505	482	460	437	415	389	369	349	329	–	–
	1	MIN	445	425	405	387	368	348	331	314	299	–	–
DFCL 5	5	MAX	867	867	836	806	777	747	719	688	657	622	583
	4		766	739	713	686	659	630	601	569	533	492	–
	3	MED	689	660	634	607	580	554	528	501	471	435	–
	2		612	587	563	540	517	493	470	444	416	384	–
	1	MIN	536	516	496	475	454	431	406	380	353	–	–

Correction factors for Total cooling emission

MODEL	Speed		Available pressure (Pa)										
			0	20	40	60	80	100	120	140	160	180	200
DFCL 1	5	MAX	1,00	0,97	0,94	0,91	0,86	0,79	0,70	–	–	–	–
	4		1,00	0,97	0,94	0,90	0,85	0,78	0,67	–	–	–	–
	3	MED	1,00	0,97	0,94	0,90	0,83	0,75	–	–	–	–	–
	2		1,00	0,96	0,91	0,86	0,79	0,71	–	–	–	–	–
	1	MIN	1,00	0,93	0,87	0,81	0,74	–	–	–	–	–	–
DFCL 2	5	MAX	1,00	0,97	0,94	0,92	0,88	0,83	0,76	0,12	–	–	–
	4		1,00	0,98	0,95	0,93	0,89	0,85	0,77	–	–	–	–
	3	MED	1,00	0,98	0,97	0,95	0,92	0,87	0,79	–	–	–	–
	2		1,00	0,99	0,99	0,97	0,96	0,93	0,88	–	–	–	–
	1	MIN	1,00	0,99	0,97	0,96	0,94	0,90	–	–	–	–	–
DFCL 3	5	MAX	1,00	0,98	0,97	0,95	0,93	0,90	0,87	0,83	0,79	0,74	–
	4		1,00	0,98	0,96	0,94	0,92	0,89	0,85	0,81	0,76	0,71	–
	3	MED	1,00	0,98	0,97	0,95	0,92	0,89	0,86	0,82	0,77	0,71	–
	2		1,00	0,98	0,97	0,95	0,93	0,90	0,86	0,82	0,77	–	–
	1	MIN	1,00	0,98	0,97	0,95	0,92	0,89	0,86	0,81	0,76	–	–
DFCL 4	5	MAX	1,00	0,98	0,97	0,95	0,93	0,90	0,87	0,84	0,79	0,74	0,69
	4		1,00	0,98	0,97	0,95	0,93	0,91	0,87	0,83	0,79	0,73	–
	3	MED	1,00	0,98	0,97	0,95	0,93	0,90	0,86	0,82	0,76	0,71	–
	2		1,00	0,98	0,97	0,95	0,92	0,89	0,85	0,81	0,76	–	–
	1	MIN	1,00	0,98	0,97	0,95	0,92	0,89	0,85	0,80	0,76	–	–
DFCL 5	5	MAX	1,00	1,00	0,98	0,97	0,95	0,93	0,91	0,88	0,85	0,81	0,76
	4		1,00	0,99	0,97	0,96	0,94	0,91	0,89	0,85	0,81	0,74	–
	3	MED	1,00	0,99	0,97	0,96	0,94	0,92	0,89	0,86	0,81	0,74	–
	2		1,00	0,98	0,97	0,95	0,93	0,90	0,87	0,84	0,79	0,72	–
	1	MIN	1,00	0,98	0,97	0,95	0,93	0,90	0,86	0,80	0,74	–	–

Correction factors
for Sensible cooling emission and Heating emission

MODEL	Speed		Available pressure (Pa)										
			0	20	40	60	80	100	120	140	160	180	200
DFCL 1	5	MAX	1,00	0,96	0,92	0,88	0,82	0,75	0,64	–	–	–	–
	4		1,00	0,96	0,92	0,87	0,81	0,73	0,61	–	–	–	–
	3	MED	1,00	0,96	0,92	0,87	0,79	0,69	–	–	–	–	–
	2		1,00	0,94	0,89	0,82	0,74	0,65	–	–	–	–	–
	1	MIN	1,00	0,91	0,83	0,76	0,68	–	–	–	–	–	–
DFCL 2	5	MAX	1,00	0,96	0,93	0,89	0,84	0,79	0,71	0,07	–	–	–
	4		1,00	0,97	0,94	0,90	0,86	0,80	0,72	–	–	–	–
	3	MED	1,00	0,98	0,96	0,93	0,89	0,83	0,74	–	–	–	–
	2		1,00	0,99	0,98	0,97	0,94	0,91	0,85	–	–	–	–
	1	MIN	1,00	0,98	0,97	0,95	0,92	0,87	–	–	–	–	–
DFCL 3	5	MAX	1,00	0,98	0,96	0,94	0,91	0,87	0,84	0,79	0,74	0,68	–
	4		1,00	0,98	0,95	0,92	0,89	0,85	0,81	0,76	0,71	0,65	–
	3	MED	1,00	0,98	0,95	0,93	0,90	0,86	0,82	0,77	0,72	0,66	–
	2		1,00	0,98	0,96	0,94	0,91	0,87	0,83	0,77	0,71	–	–
	1	MIN	1,00	0,98	0,96	0,93	0,90	0,86	0,82	0,76	0,70	–	–
DFCL 4	5	MAX	1,00	0,98	0,96	0,94	0,91	0,87	0,84	0,80	0,74	0,69	0,63
	4		1,00	0,98	0,96	0,94	0,91	0,88	0,84	0,79	0,74	0,67	–
	3	MED	1,00	0,98	0,96	0,93	0,90	0,87	0,82	0,77	0,71	0,65	–
	2		1,00	0,98	0,96	0,93	0,90	0,85	0,81	0,76	0,70	–	–
	1	MIN	1,00	0,98	0,95	0,93	0,90	0,85	0,81	0,76	0,71	–	–
DFCL 5	5	MAX	1,00	1,00	0,98	0,96	0,93	0,91	0,88	0,85	0,81	0,77	0,71
	4		1,00	0,98	0,96	0,94	0,92	0,89	0,85	0,81	0,76	0,69	–
	3	MED	1,00	0,98	0,97	0,95	0,92	0,90	0,86	0,82	0,76	0,68	–
	2		1,00	0,98	0,96	0,93	0,90	0,87	0,84	0,79	0,74	0,66	–
	1	MIN	1,00	0,98	0,96	0,93	0,90	0,86	0,82	0,76	0,68	–	–

DFCL 1÷5 | Water side pressure drop

2 pipe units

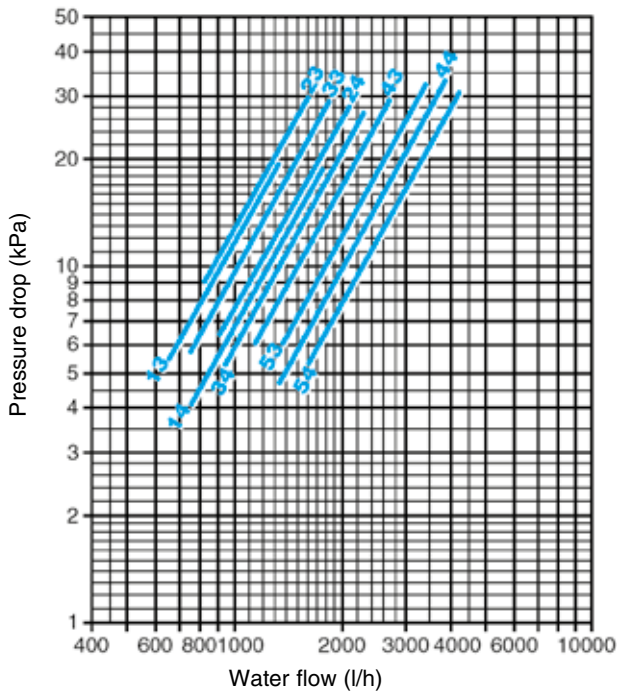

The water pressure drop figures refer to a mean water temperature of **10 °C**; for different temperatures, multiply the pressure drop figures by the correction factors **K**.

°C	20	30	40	50	60	70	80
K	0,94	0,90	0,86	0,82	0,78	0,74	0,70

4 pipe units (heating coil pressure drop)

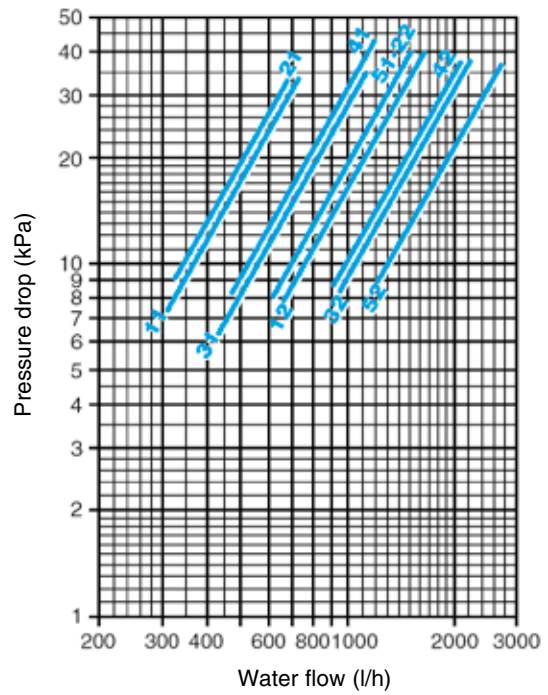

The water pressure drop figures refer to a mean water temperature of **60 °C**; for different temperatures, multiply the pressure drop figures by the correction factors **K**.

°C	40	50	70	80
K	1,12	1,06	0,94	0,88

Accessory air side pressure drop

Spigot plenum pressure drop

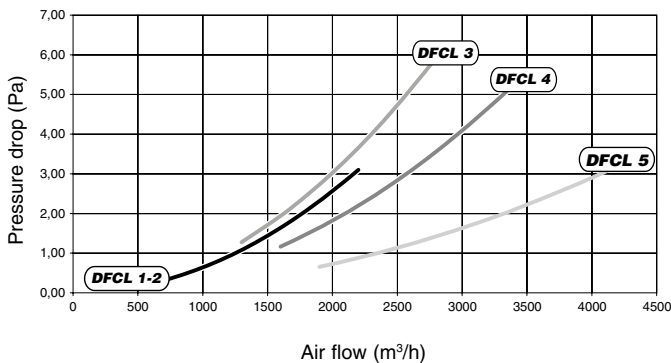

48 mm G4 filter pressure drop

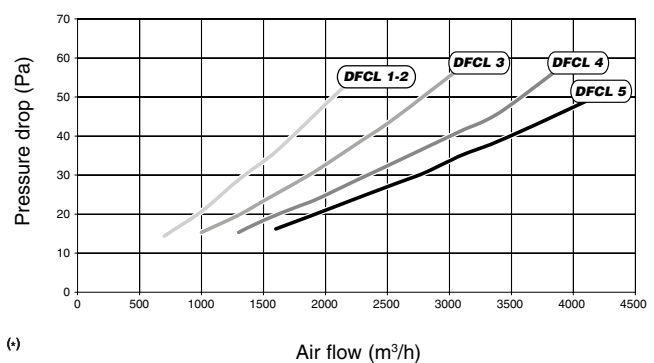

Following many years of experience in the field of heating and air conditioning, we have developed a range of **DFCL** fan coils for concealed installation and connection to a duct system.

Sizes 6÷7 supply a consistent air flow with static pressure up to 250 Pa to fit most conditions, with the combination of either 4 or 6 row heating coils and 2 or 4 pipe configurations with 2 row additional heating coil.

The fan assembly has 3 speeds.

Compliant with Regulation (EU) No. 327/2011

Construction features

CASING

It is made with 1,2 mm galvanized steel for sizes 6-7, insulated with 10 mm polyolefin (PO) foam (class M1).

FAN ASSEMBLY

Consists of quiet centrifugal fans with two impellers and a directly driven single phase, three speed motor, 230V 50Hz, with external rotor, capacitor, insulation class F.

COIL

It is manufactured from drawn copper tube and the aluminium fins are mechanically bonded onto the tube by an expansion process.

The **DFCL** range (sizes 6÷7) is available with the combination of either 4 or 6 row coils with the possibility to add a 2 row coil (4+2, 6+2 versions for 4 pipe systems).

The connections are on the left hand side looking from the air inlet of the unit (see picture and drawing to the next page). On request the connections can be moved to the other side.

The heat exchanger is not suitable for use in corrosive atmosphere or in environments where aluminium may be subject to corrosion.

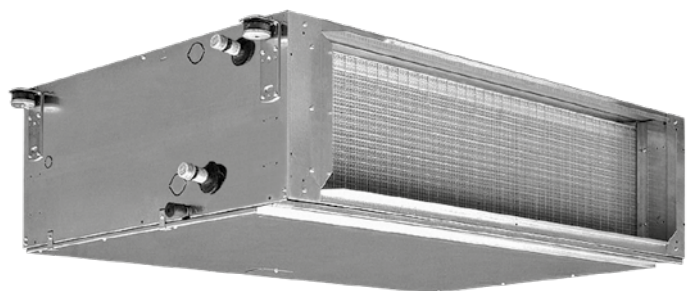

FILTER

The filter is made of polypropylene cellular fabric regenerating filter. The filter frame of galvanized steel is inserted into sliding guides fastened to the internal structure for easy insertion and removal of the filter.

CONDENSATE COLLECTION TRAY

It is made from galvanized steel insulated with 3 mm polyolefin (PO) foam (class M1).

Left connections (standard)

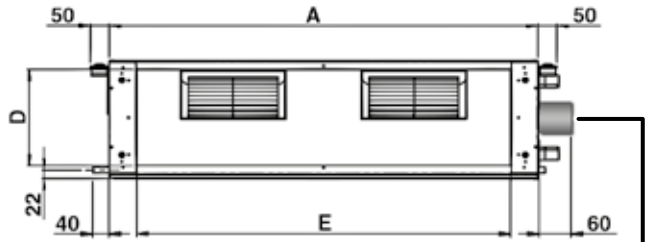
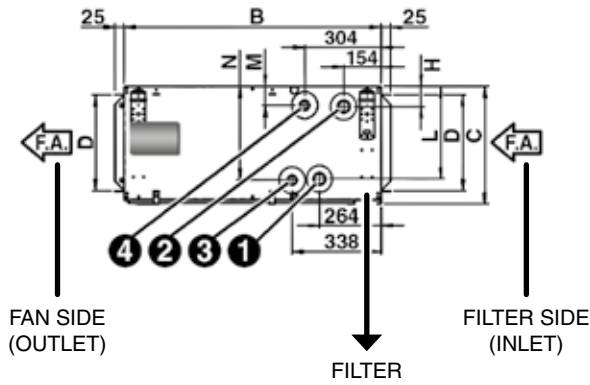

Right connections (on request)

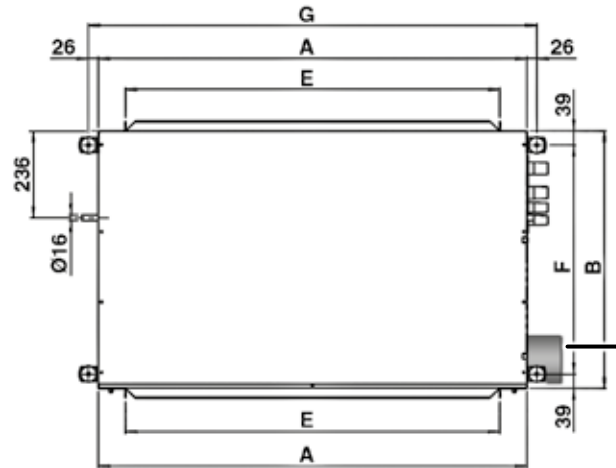
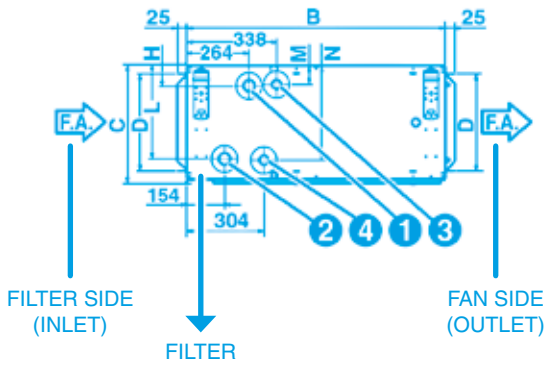

STANDARD

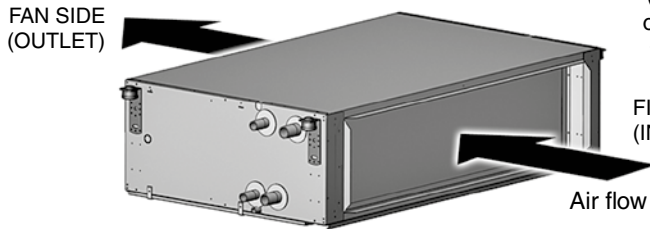

(coil connections on the left looking the air direction)

FILTER SIDE (INLET)

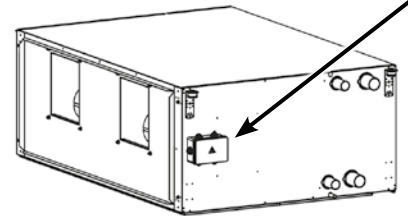

Wiring terminal board

MODEL	Dimensions (mm)											Coil			
	A	B	C	D	E	F	G	H	L	M	N	Main		Additional	
												① IN	② OUT	③ IN	④ OUT
DFCL 6	1535	1100	488	421	1393	1022	1587	59	416	55	421	1 1/4"	1 1/4"	1"	1"
DFCL 7	1535	1100	588	521	1393	1022	1587	59	516	55	521	1 1/4"	1 1/4"	1"	1"

MODEL	Weight without packaging (kg)				Weight with packaging (kg)				Water content (l)		
	4R	4+2R	6R	6+2R	4R	4+2R	6R	6+2R	4R	6R	2R
DFCL 6	124	134	130	140	127	137	133	143	7,6	11,1	4,1
DFCL 7	140	152	148	160	143	155	151	163	9,7	13,8	5,5

Water circuit	Maximum water pressure: 1000 kPa (10 bars)	MIN. entering water temperature: + 6 °C
		MAX. entering water temperature: + 80 °C
Air flow	Suitable relative humidity 15-75%	MIN. entering air temperature: + 6 °C
		MAX. entering air temperature: + 40 °C
		MAX. leaving air temperature: + 50 °C
Supply	Single phase 230V 50Hz	

Motor electrical data (max. absorption)

MODEL		DFCL 6	DFCL 7
230/1 50Hz	W	1437	2817
	A	6,38	12,40

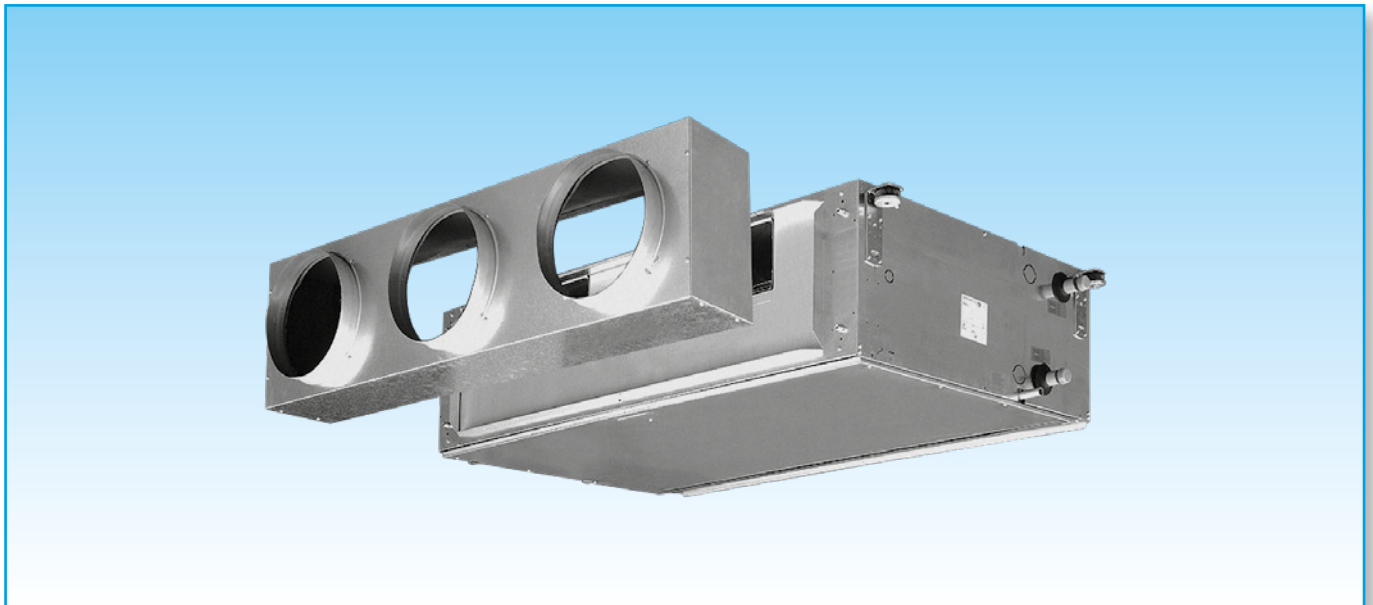

DFCL 6÷7 | Main performance and technical characteristics

2 pipe units. The following standard rating conditions are used:

COOLING (summer mode)

Entering air temperature +27 °C d.b. +19 °C b.u.
Water temperature + 7 °C E.W.T. +12 °C L.W.T.

HEATING (winter mode)

Entering air temperature +20 °C
Water temperature +60 °C E.W.T. +50 °C L.W.T.

DFCL UNITS WITH 4 AND 6 ROW COIL

AVAILABLE PRESSURE: 0 Pa

MODEL		DFCL 64			DFCL 66			DFCL 74			DFCL 76		
		1	2	3	1	2	3	1	2	3	1	2	3
Speed													
Air flow	m ³ /h	2200	3580	5200	2190	3570	5170	3960	5210	7480	3960	5210	7435
Cooling total emission	kW	13,83	19,28	23,94	16,28	23,47	29,89	21,45	25,55	31,22	26,09	31,62	39,52
Cooling sensible emission	kW	9,99	14,64	18,98	11,25	16,90	22,32	16,04	19,66	25,14	18,44	23,02	29,94
Heating	kW	23,77	35,01	46,21	26,09	39,57	53,27	39,61	48,83	63,38	44,57	55,84	73,68
Dp Cooling	kPa	9,0	16,4	24,6	11,6	22,2	34,8	14,6	19,8	29,1	18,6	26,1	39,5
Dp Heating	kPa	4,9	9,9	16,3	5,7	12,1	20,6	8,6	12,5	20,0	9,9	14,8	24,4
Fan	W	732	943	1437	715	933	1414	1666	1879	2803	1666	1879	2764
Sound power Lw	dB(A)	61	69	76	61	69	76	68	74	81	68	74	81
Sound pressure (*)	dB(A)	52	60	67	52	60	67	59	65	72	59	65	72

AVAILABLE PRESSURE: 150 Pa

MODEL		DFCL 64			DFCL 66			DFCL 74			DFCL 76		
		1	2	3	1	2	3	1	2	3	1	2	3
Speed													
Air flow	m ³ /h	1880	3385	4800	1860	3350	4740	3925	5070	7100	3920	5050	7030
Cooling total emission	kW	12,42	18,73	22,89	14,36	22,59	28,28	21,54	25,33	30,63	26,09	31,17	38,42
Cooling sensible emission	kW	8,88	14,16	17,98	9,84	16,20	20,91	16,05	19,46	24,53	18,49	22,66	28,96
Heating	kW	20,86	33,52	43,60	22,58	37,53	49,77	39,34	47,85	61,14	44,20	54,45	70,64
Dp Cooling	kPa	7,4	15,3	22,6	9,2	20,5	31,4	14,4	19,3	27,6	18,3	25,1	37,1
Dp Heating	kPa	3,9	9,1	14,7	4,4	11,0	18,2	8,5	12,1	18,8	9,7	14,2	22,6
Fan	W	570	788	1191	565	771	1163	1610	1738	2502	1605	1720	2452
Sound power Lw	dB(A)	63	71	77	63	71	77	71	75	81	71	75	81
Sound pressure (*)	dB(A)	54	62	68	54	62	68	62	66	72	62	66	72

4 pipe units. The following standard rating conditions are used:

COOLING (summer mode)

Entering air temperature +27 °C d.b. +19 °C b.u.
Water temperature + 7 °C E.W.T. +12 °C L.W.T.

HEATING (winter mode)

Entering air temperature +20 °C
Water temperature +70 °C E.W.T. +60 °C L.W.T.

DFCL UNITS WITH 4+2 AND 6+2 ROW COIL

AVAILABLE PRESSURE: 0 Pa

MODEL		DFCL 64+2			DFCL 66+2			DFCL 74+2			DFCL 76+2		
		1	2	3	1	2	3	1	2	3	1	2	3
Speed													
Air flow	m ³ /h	2190	3570	5150	2180	3570	5125	3960	5210	7410	3960	5210	7355
Cooling total emission	kW	13,80	19,24	23,81	16,21	23,47	29,75	21,45	25,55	31,16	26,09	31,62	39,28
Cooling sensible emission	kW	9,97	14,61	18,87	11,20	16,90	22,20	15,95	19,66	25,06	18,44	23,02	29,73
Heating	kW	22,28	31,16	39,42	22,21	31,16	39,27	35,74	42,78	53,25	35,74	42,78	52,98
Dp Cooling	kPa	9,0	16,3	24,3	11,5	22,2	34,4	14,6	19,8	28,9	18,6	26,1	38,9
Dp Heating	kPa	14,7	27,0	41,2	14,7	27,0	40,9	24,1	33,3	49,3	24,1	33,3	48,9
Fan	W	715	933	1400	708	933	1382	1666	1879	2743	1666	1879	2698
Sound power Lw	dB(A)	61	69	76	61	69	76	68	74	81	68	74	81
Sound pressure (*)	dB(A)	52	60	67	52	60	67	59	65	72	59	65	72

AVAILABLE PRESSURE: 150 Pa

MODEL		DFCL 64+2			DFCL 66+2			DFCL 74+2			DFCL 76+2		
		1	2	3	1	2	3	1	2	3	1	2	3
Speed													
Air flow	m ³ /h	1860	3330	4680	1850	3300	4600	3920	5040	6980	3910	5000	6900
Cooling total emission	kW	12,33	18,56	22,52	14,10	22,04	27,53	21,53	25,25	30,36	26,08	30,98	38,04
Cooling sensible emission	kW	8,81	14,02	17,62	9,59	15,70	20,26	16,05	19,39	24,28	18,48	22,51	28,62
Heating	kW	19,81	29,78	37,13	19,73	29,59	36,76	35,50	41,88	51,31	35,41	41,68	50,95
Dp Cooling	kPa	7,3	15,0	22,0	9,1	20,1	30,3	14,4	19,1	27,1	18,3	24,8	36,3
Dp Heating	kPa	11,9	24,9	37,0	11,8	24,6	36,3	23,8	32,0	46,1	23,7	31,7	45,5
Fan	W	565	762	1137	560	749	1105	1605	1710	2417	1587	1677	2364
Sound power Lw	dB(A)	63	71	77	63	71	77	71	75	81	71	75	81
Sound pressure (*)	dB(A)	54	62	68	54	62	68	62	66	72	62	66	72

(*) = The sound pressure levels are 9 dB(A) lower than the sound power levels and apply to the reverberant field of a 100 m³ room and a reverberation time of 0.5 sec.

Cooling emission of 4 row coil

Entering air temperature: 27 °C – R. H.: 50% – AVAILABLE PRESSURE: 0 Pa

MODEL	Speed		WT: 7/12 °C				WT: 8/13 °C				WT: 10/15 °C				WT: 12/17 °C				
			Qv	Pc	Ps	Qw	Dp(c)	Pc	Ps	Qw	Dp(c)	Pc	Ps	Qw	Dp(c)	Pc	Ps	Qw	Dp(c)
			m³/h	kW	kW	l/h	kPa	kW	kW	l/h	kPa	kW	kW	l/h	kPa	kW	kW	l/h	kPa
DFCL 64	3	MAX	5200	27,34	20,66	4702	28,1	24,47	19,80	4208	22,9	19,14	18,22	3292	14,6	14,66	14,66	2521	9,0
	2	MED	3580	21,84	15,72	3757	18,8	19,51	14,93	3355	15,3	15,15	13,49	2605	9,6	11,43	11,43	1966	5,7
	1	MIN	2200	15,74	10,80	2707	10,4	14,06	10,16	2418	8,5	10,86	9,00	1868	5,3	8,07	8,04	1387	3,1
DFCL 74	3	MAX	7480	36,63	28,38	6300	33,2	32,78	27,28	5638	27,1	25,78	25,34	4434	17,4	19,87	19,87	3418	10,8
	2	MED	5210	29,70	21,85	5108	22,8	26,55	20,83	4566	18,5	20,71	19,00	3561	11,7	15,70	15,70	2700	7,1
	1	MIN	3960	25,08	17,85	4314	16,8	22,39	16,90	3852	13,6	17,34	15,20	2982	8,5	13,05	13,05	2244	5,1

Cooling emission of 4 row coil

Entering air temperature: 26 °C – R. H.: 50% – AVAILABLE PRESSURE: 0 Pa

MODEL	Speed		WT: 7/12 °C				WT: 8/13 °C				WT: 10/15 °C				WT: 12/17 °C				
			Qv	Pc	Ps	Qw	Dp(c)	Pc	Ps	Qw	Dp(c)	Pc	Ps	Qw	Dp(c)	Pc	Ps	Qw	Dp(c)
			m³/h	kW	kW	l/h	kPa	kW	kW	l/h	kPa	kW	kW	l/h	kPa	kW	kW	l/h	kPa
DFCL 64	3	MAX	5200	24,32	19,77	4183	22,8	21,66	18,95	3725	18,4	16,79	16,79	2887	11,5	12,78	12,78	2197	7,0
	2	MED	3580	19,42	14,95	3339	15,2	17,20	14,18	2959	12,2	13,19	12,83	2269	7,5	9,88	9,88	1700	4,4
	1	MIN	2200	13,97	10,19	2403	8,4	12,36	9,57	2126	6,7	9,39	8,49	1616	4,1	6,91	6,91	1189	2,3
DFCL 74	3	MAX	7480	32,65	27,26	5616	27,0	29,10	26,22	5005	21,8	22,71	22,71	3906	13,8	17,39	17,39	2991	8,5
	2	MED	5210	26,41	20,83	4542	18,4	23,47	19,87	4037	14,8	18,09	18,09	3111	9,2	13,63	13,63	2344	5,5
	1	MIN	3960	22,26	16,92	3830	13,5	19,73	16,03	3394	10,9	15,10	14,44	2597	6,6	11,26	11,26	1936	3,9

Cooling emission of 4 row coil

Entering air temperature: 25 °C – R. H.: 50% – AVAILABLE PRESSURE: 0 Pa

MODEL	Speed		WT: 7/12 °C				WT: 8/13 °C				WT: 10/15 °C				WT: 12/17 °C				
			Qv	Pc	Ps	Qw	Dp(c)	Pc	Ps	Qw	Dp(c)	Pc	Ps	Qw	Dp(c)	Pc	Ps	Qw	Dp(c)
			m³/h	kW	kW	l/h	kPa	kW	kW	l/h	kPa	kW	kW	l/h	kPa	kW	kW	l/h	kPa
DFCL 64	3	MAX	5200	21,58	18,92	3711	18,4	19,10	18,12	3285	14,7	14,70	14,70	2529	9,1	12,96	12,96	2230	7,2
	2	MED	3580	17,13	14,18	2947	12,1	15,09	13,45	2595	9,6	11,48	11,48	1974	5,8	9,54	9,54	1640	4,1
	1	MIN	2200	12,30	9,59	2116	6,7	10,81	9,01	1859	5,3	8,09	8,00	1392	3,1	5,99	5,99	1031	1,8
DFCL 74	3	MAX	7480	29,02	26,17	4992	21,8	25,74	25,16	4427	17,5	19,95	19,95	3431	11,0	17,70	17,70	3044	8,8
	2	MED	5210	23,37	19,84	4020	14,8	20,63	18,92	3549	11,8	15,76	15,76	2711	7,2	13,75	13,75	2365	5,6
	1	MIN	3960	19,63	16,02	3376	10,8	17,29	15,18	2974	8,6	13,09	13,09	2252	5,1	10,61	10,61	1824	3,5

Note: the power absorption (Watt) at page 30 must be subtracted from the total and sensible cooling emission.

LEGEND

- WT = Water temperature
- Pc = Cooling total emission
- Ps = Cooling sensible emission
- Qw = Water flow
- Dp(c) = Water pressure drop
- Speed = Fan speed
- MAX = High speed
- MED = Medium speed
- MIN = Low speed
- Qv = Air flow

Cooling emission of 6 row coil

Entering air temperature: 27 °C – R. H.: 50% – AVAILABLE PRESSURE: 0 Pa

MODEL	Speed		WT: 7/12 °C					WT: 8/13 °C				WT: 10/15 °C				WT: 12/17 °C			
			Qv	Pc	Ps	Qw	Dp(c)	Pc	Ps	Qw	Dp(c)	Pc	Ps	Qw	Dp(c)	Pc	Ps	Qw	Dp(c)
			m³/h	kW	kW	l/h	kPa	kW	kW	l/h	kPa	kW	kW	l/h	kPa	kW	kW	l/h	kPa
DFCL 66	3	MAX	5170	33,72	23,82	5799	39,7	30,21	22,56	5196	32,5	23,54	20,26	4049	20,5	17,76	17,76	3055	12,2
	2	MED	3570	26,33	17,92	4529	25,5	23,62	16,87	4063	20,8	18,35	14,93	3157	13,1	13,68	13,29	2354	7,7
	1	MIN	2190	18,29	12,03	3146	13,2	16,47	11,28	2833	10,9	12,82	9,84	2204	6,9	9,47	8,60	1628	3,9
DFCL 76	3	MAX	7435	45,41	32,78	7811	44,9	40,68	31,16	6998	36,7	31,79	28,21	5468	23,3	24,13	24,13	4151	14,1
	2	MED	5210	36,21	25,10	6228	29,9	32,43	23,68	5579	24,4	25,24	21,11	4341	15,4	18,91	18,91	3252	9,1
	1	MIN	3960	29,97	20,26	5156	21,3	26,89	19,05	4625	17,4	20,88	16,79	3591	10,9	15,53	14,90	2672	6,4

Cooling emission of 6 row coil

Entering air temperature: 26 °C – R. H.: 50% – AVAILABLE PRESSURE: 0 Pa

MODEL	Speed		WT: 7/12 °C					WT: 8/13 °C				WT: 10/15 °C				WT: 12/17 °C			
			Qv	Pc	Ps	Qw	Dp(c)	Pc	Ps	Qw	Dp(c)	Pc	Ps	Qw	Dp(c)	Pc	Ps	Qw	Dp(c)
			m³/h	kW	kW	l/h	kPa	kW	kW	l/h	kPa	kW	kW	l/h	kPa	kW	kW	l/h	kPa
DFCL 66	3	MAX	5170	30,04	22,60	5167	32,3	26,67	21,37	4587	25,9	20,53	19,22	3530	16,0	15,34	15,34	2639	9,4
	2	MED	3570	23,47	16,92	4037	20,7	20,84	15,90	3585	16,6	15,92	14,06	2739	10,2	11,74	11,74	2019	5,8
	1	MIN	2190	16,35	11,32	2812	10,8	14,55	10,57	2503	8,7	11,07	9,20	1905	5,3	8,06	8,06	1386	3,0
DFCL 76	3	MAX	7435	40,52	31,21	6969	36,6	36,00	29,63	6192	29,4	27,82	26,86	4785	18,3	20,93	20,93	3601	10,9
	2	MED	5210	32,24	23,74	5545	24,2	28,64	22,38	4926	19,5	21,91	19,94	3769	11,9	16,28	16,28	2800	6,9
	1	MIN	3960	26,70	19,10	4592	17,3	23,71	17,92	4077	13,9	18,09	15,80	3112	8,4	13,30	13,30	2287	4,8

Cooling emission of 6 row coil

Entering air temperature: 25 °C – R. H.: 50% – AVAILABLE PRESSURE: 0 Pa

MODEL	Speed		WT: 7/12 °C					WT: 8/13 °C				WT: 10/15 °C				WT: 12/17 °C			
			Qv	Pc	Ps	Qw	Dp(c)	Pc	Ps	Qw	Dp(c)	Pc	Ps	Qw	Dp(c)	Pc	Ps	Qw	Dp(c)
			m³/h	kW	kW	l/h	kPa	kW	kW	l/h	kPa	kW	kW	l/h	kPa	kW	kW	l/h	kPa
DFCL 66	3	MAX	5170	26,56	21,38	4568	25,9	23,44	20,24	4032	20,6	17,82	17,82	3065	12,4	13,35	13,35	2296	7,3
	2	MED	3570	20,73	15,93	3566	16,6	18,25	14,95	3139	13,1	13,74	13,25	2363	7,8	10,05	10,05	1729	4,4
	1	MIN	2190	14,47	10,61	2489	8,7	12,74	9,89	2192	6,9	9,51	8,61	1636	4,0	6,85	6,85	1179	2,2
DFCL 76	3	MAX	7435	35,88	29,64	6172	29,4	31,72	28,16	5455	23,4	24,23	24,23	4168	14,3	19,15	19,15	3294	9,3
	2	MED	5210	28,52	22,41	4905	19,4	25,12	21,11	4320	15,4	19,00	18,86	3267	9,2	13,99	13,99	2406	5,3
	1	MIN	3960	23,61	17,97	4061	13,8	20,77	16,84	3573	10,9	15,60	14,87	2684	6,5	11,38	11,38	1957	3,6

Note: the power absorption (Watt) at page 30 must be subtracted from the total and sensible cooling emission.

LEGEND

- WT = Water temperature
- Pc = Cooling total emission
- Ps = Cooling sensible emission
- Qw = Water flow
- Dp(c) = Water pressure drop
- Speed = Fan speed
- MAX = High speed
- MED = Medium speed
- MIN = Low speed
- Qv = Air flow

Heating emission of 4 row coil

Entering air temperature: 20 °C – AVAILABLE PRESSURE: 0 Pa

MODEL	Speed		WT: 60/50 °C			WT: 55/45 °C			WT: 50/40 °C			WT: 50/45 °C			WT: 45/40 °C			
			Qv	Ph	Qw	Dp(c)	Ph	Qw	Dp(c)	Ph	Qw	Dp(c)	Ph	Qw	Dp(c)	Ph	Qw	Dp(c)
			m³/h	kW	l/h	kPa	kW	l/h	kPa	kW	l/h	kPa	kW	l/h	kPa	kW	l/h	kPa
DFCL 64	3	MAX	5200	46,21	3974	16,3	39,30	3380	12,4	32,35	2782	8,9	36,45	6269	38,0	29,65	5100	26,7
	2	MED	3580	35,01	3011	9,9	29,85	2567	7,5	24,67	2122	5,5	27,45	4722	22,8	22,38	3849	16,1
	1	MIN	2200	23,77	2044	4,9	20,35	1750	3,8	16,91	1455	2,8	18,51	3183	11,2	15,14	2605	8,0
DFCL 74	3	MAX	7480	63,38	5450	20,0	53,87	4632	15,2	44,26	3806	10,9	50,07	8613	46,9	40,68	6998	32,9
	2	MED	5210	48,83	4199	12,5	41,59	3577	9,6	34,31	2951	6,9	38,39	6603	29,1	31,29	5381	20,5
	1	MIN	3960	39,61	3406	8,6	33,82	2908	6,6	27,99	2407	4,8	31,03	5337	19,8	25,31	4353	14,0

Heating emission of 6 row coil

Entering air temperature: 20 °C – AVAILABLE PRESSURE: 0 Pa

MODEL	Speed		WT: 55/45 °C			WT: 50/40 °C			WT: 50/45 °C			WT: 45/40 °C			
			Qv	Ph	Qw	Dp(c)	Ph	Qw	Dp(c)	Ph	Qw	Dp(c)	Ph	Qw	Dp(c)
			m³/h	kW	l/h	kPa	kW	l/h	kPa	kW	l/h	kPa	kW	l/h	kPa
DFCL 66	3	MAX	5170	45,60	3922	15,9	37,92	3261	11,6	41,53	7143	47,1	33,97	5843	33,4
	2	MED	3570	33,99	2923	9,3	28,36	2439	6,9	30,66	5274	27,3	25,16	4327	19,5
	1	MIN	2190	22,49	1934	4,4	18,86	1622	3,3	20,07	3452	12,7	16,53	2843	9,1
DFCL 76	3	MAX	7435	63,02	5420	18,7	52,30	4498	13,6	57,60	9908	56,0	47,09	8099	39,7
	2	MED	5210	47,87	4117	11,4	39,85	3427	8,4	43,42	7468	33,7	35,56	6117	24,0
	1	MIN	3960	38,30	3293	7,6	31,99	2751	5,6	34,50	5934	22,3	28,33	4873	15,9

Heating emission of 2 row additional coil

Entering air temperature: 20 °C – AVAILABLE PRESSURE: 0 Pa

MODEL	Speed		WT: 65/55 °C			WT: 60/50 °C			WT: 55/45 °C			WT: 50/40 °C			
			Qv	Ph	Qw	Dp(c)	Ph	Qw	Dp(c)	Ph	Qw	Dp(c)	Ph	Qw	Dp(c)
			m³/h	kW	l/h	kPa	kW	l/h	kPa	kW	l/h	kPa	kW	l/h	kPa
DFCL 6..+2	3	MAX	5125	34,75	2989	33,4	30,15	2593	26,3	25,49	2192	19,8	20,84	1792	14,0
	2	MED	3570	27,55	2369	22,0	23,90	2055	17,3	20,26	1742	13,1	16,59	1427	9,3
	1	MIN	2180	19,71	1695	12,0	17,13	1473	9,5	14,56	1252	7,2	11,98	1030	5,2
DFCL 7..+2	3	MAX	7355	46,94	4037	40,0	40,66	3496	31,4	34,38	2957	23,6	28,05	2412	16,7
	2	MED	5210	37,78	3249	27,0	32,76	2817	21,3	27,74	2385	16,0	22,70	1952	11,4
	1	MIN	3960	31,58	2716	19,6	27,39	2356	15,4	23,24	1999	11,7	19,06	1639	8,3

MODEL	Speed		WT: 50/45 °C			WT: 45/40 °C			WT: 45/35 °C			
			Qv	Ph	Qw	Dp(c)	Ph	Qw	Dp(c)	Ph	Qw	Dp(c)
			m³/h	kW	l/h	kPa	kW	l/h	kPa	kW	l/h	kPa
DFCL 6..+2	3	MAX	5125	24,03	4133	62,5	19,46	3346	43,6	16,16	1390	9,0
	2	MED	3570	19,01	3270	41,0	15,41	2650	28,6	12,92	1111	6,0
	1	MIN	2180	13,56	2332	22,3	11,01	1894	15,6	9,37	806	3,4
DFCL 7..+2	3	MAX	7355	32,46	5583	74,9	26,26	4517	52,1	21,70	1866	10,7
	2	MED	5210	26,11	4490	50,6	21,11	3632	35,2	17,63	1516	7,4
	1	MIN	3960	21,77	3745	36,5	17,64	3034	25,4	14,85	1277	5,4

LEGEND

WT = Water temperature
Ph = Emission
Qw = Water flow

Dp(c) = Water pressure drop
Qv = Air flow
Speed = Fan speed

MAX = High speed
MED = Medium speed
MIN = Low speed

Available pressure for **DFCL 64** (with 4 row coil)

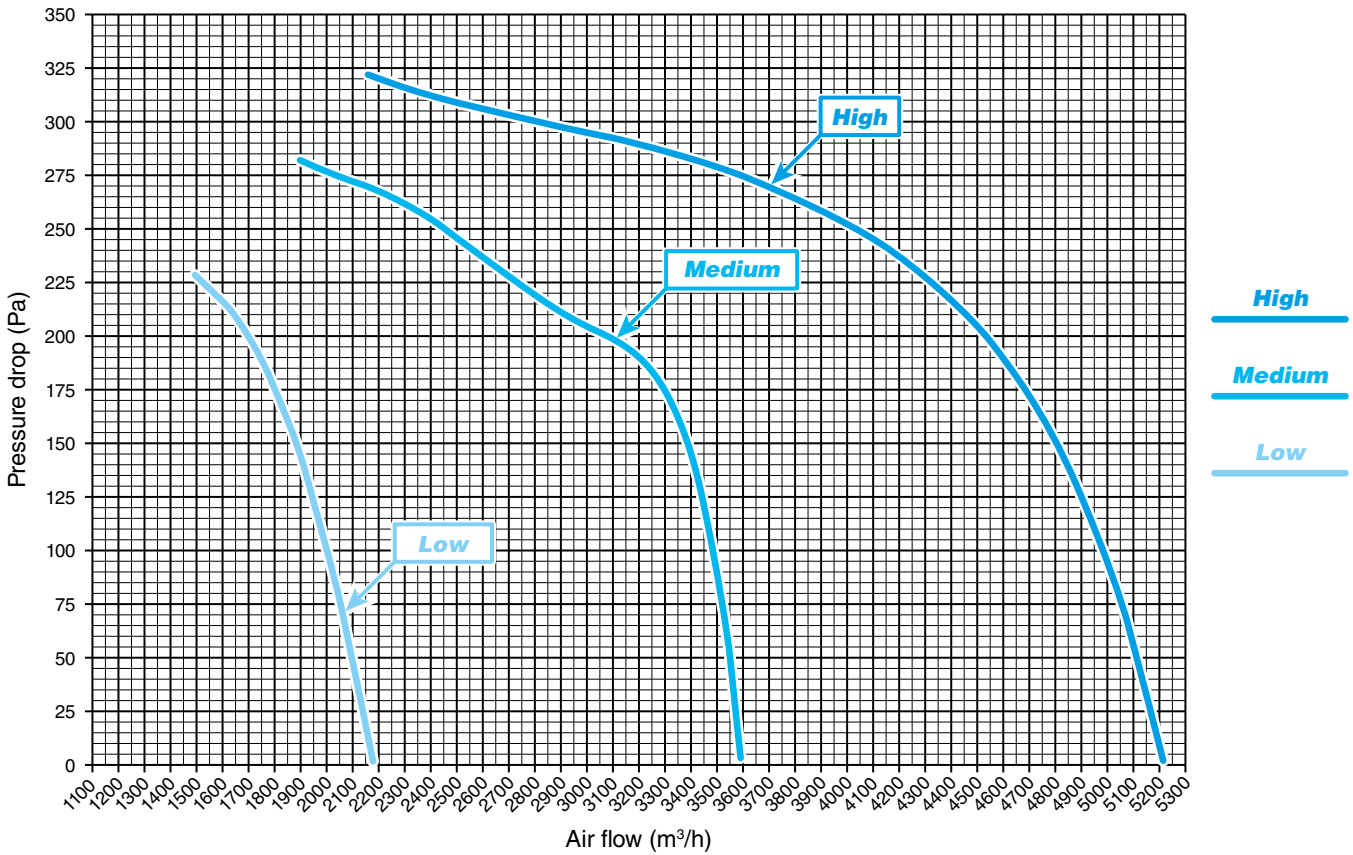

Pressure drop for **DFCL 6** (Dp)

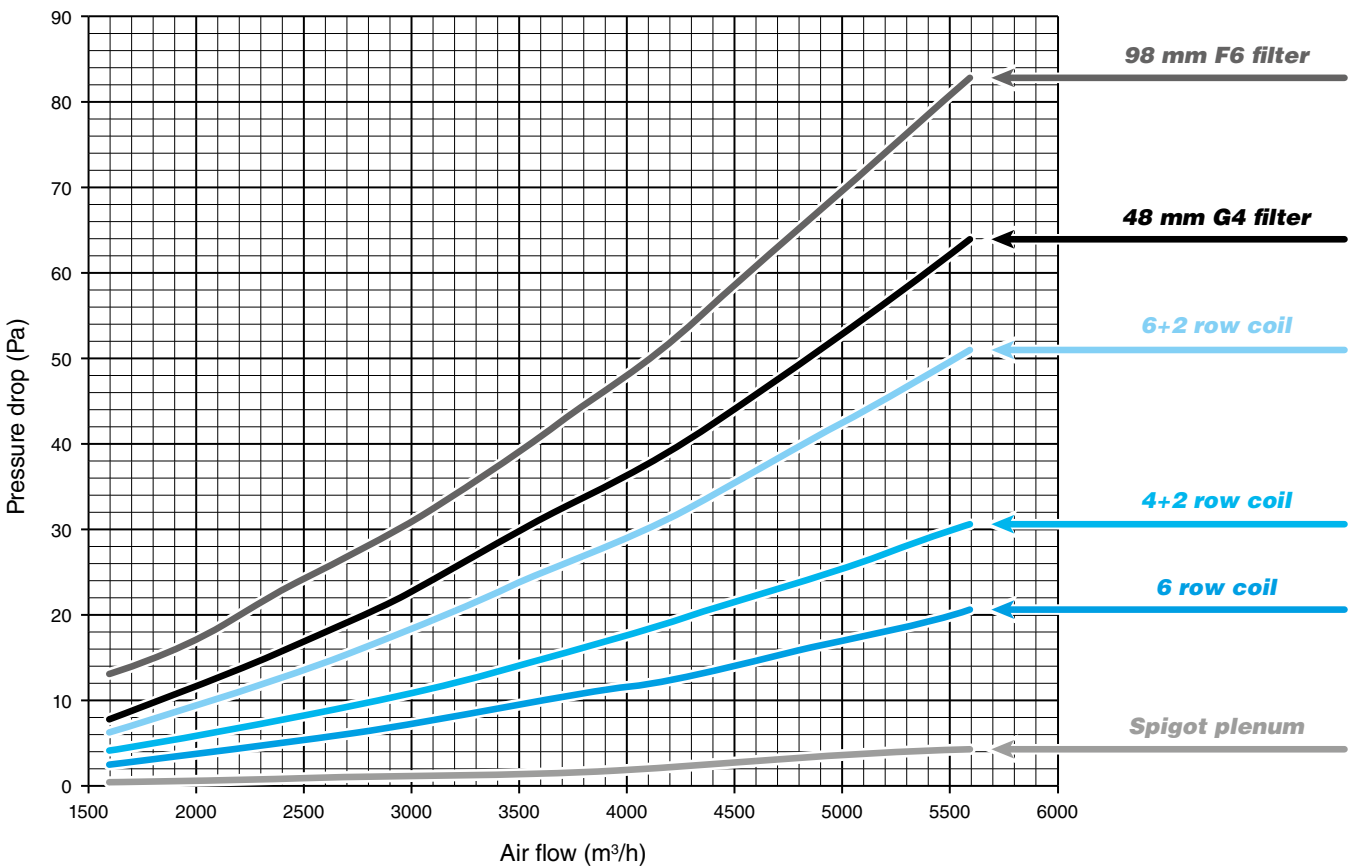

Available pressure for **DFCL 74** (with 4 row coil)

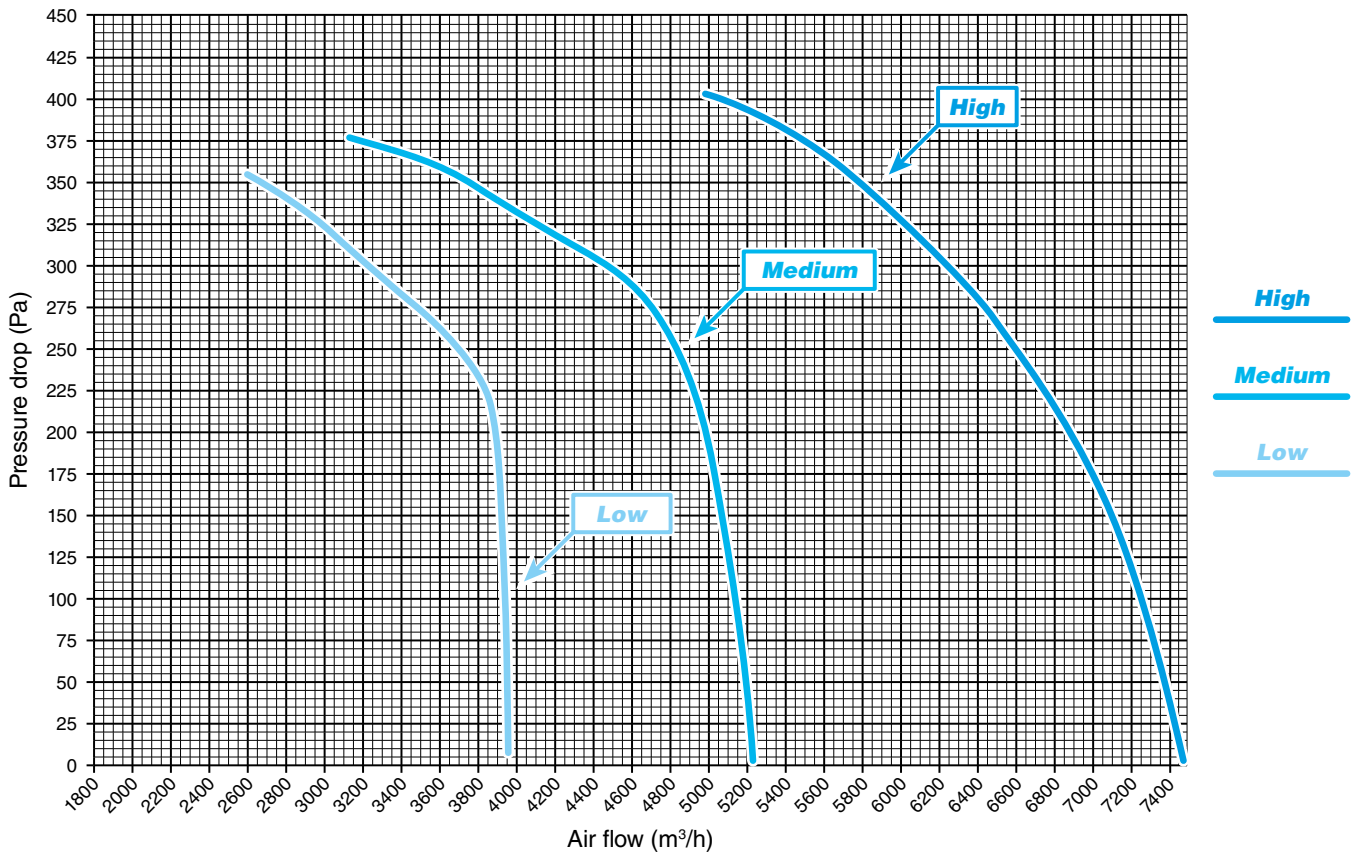

Pressure drop for **DFCL 7** (Dp)

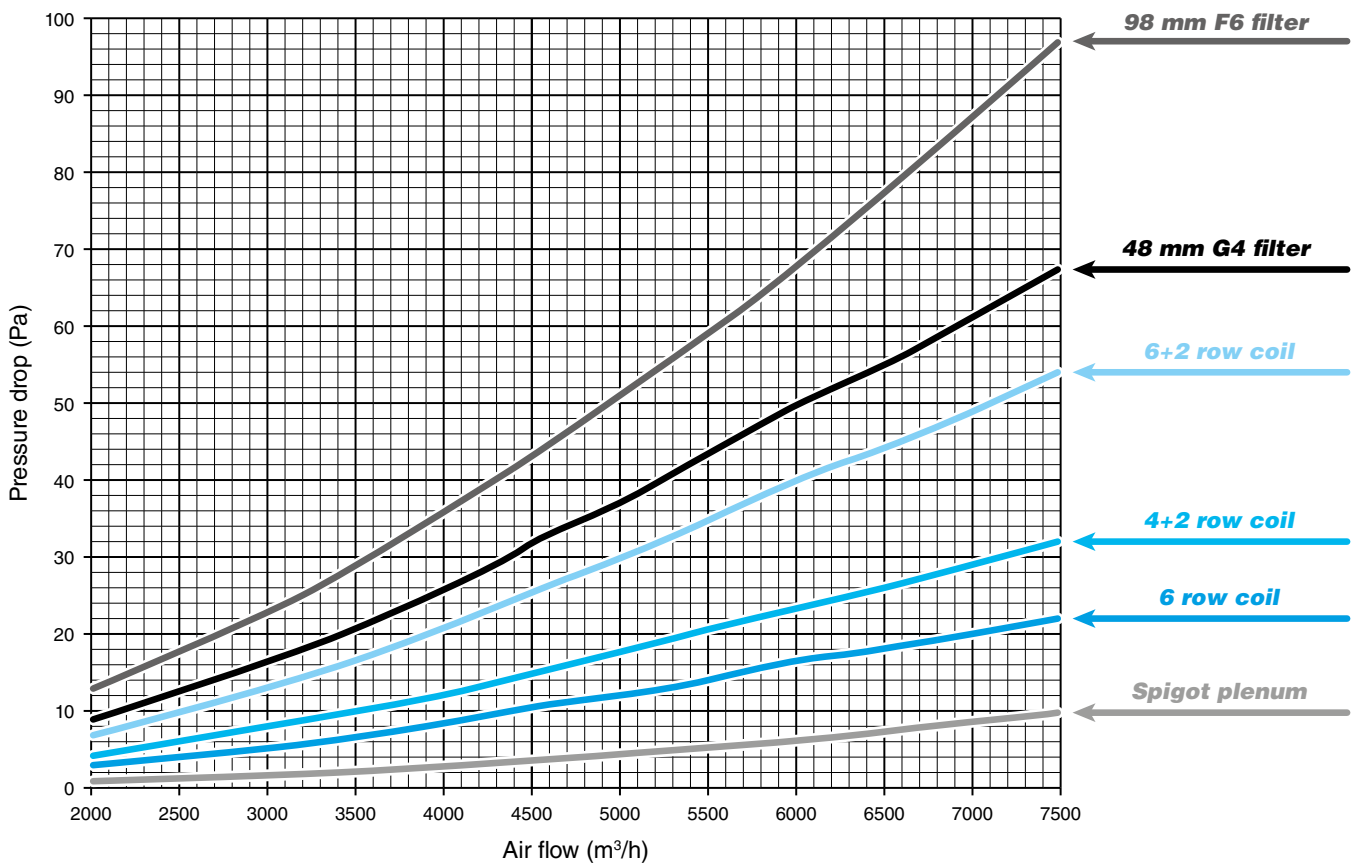

Example of calculation of the emission at different speeds and air pressure drops

Model: **DFCL 66+2**

Installation characteristics:

Summer mode:

Air temperature: + 25 °C d.b. U.R. 50%
 Water temperature: + 8 °C E.W.T. + 13 °C L.W.T.

Winter mode:

Air temperature: + 20 °C
 Water temperature: + 60 °C E.W.T. + 50 °C L.W.T.

Air flow richiesta: 3400 m³/h

Requested available pressure: 110 Pa

Emission of **DFCL 66+2** working

- at medium speed (speed 2)
- with 0 Pa of available pressure
- with entering air temperature: 25 °C

- Reference air flow rate: 3570 m³/h (page 24 - **DFCL 66**)
- Total emission: 18250 W (page 24 - **DFCL 66**)
- Sensible emission: 14950 W (page 24 - **DFCL 66**)
- Heating: 23900 W (page 25 - **DFCL 6..+2**)

Calculation of the emission at requested flow:

Define the “correction factor” between the requested air flow and the reference air flow rate (page 26):

Correction factor = requested air flow rate/reference air flow rate = $3400/3570 = 0,95$

From **Diagrams 1 and 2** define the “variation in % of the emission” using the correction factor calculated above.

- For the **TOTAL emission = 0,97**
- For the **SENSIBLE emission = 0,96**
- For the **Heating = 0,96**

The obtained emission for the unit is:

- **TOTAL emission = 18250 x 0,97 = 17703 W**
- **SENSIBLE emission = 14950 x 0,96 = 14352 W**
- **Heating = 23900 x 0,96 = 22944 W**

Correction diagram of cooling emission depending on air flow

Diagram 1 - Cooling emissions

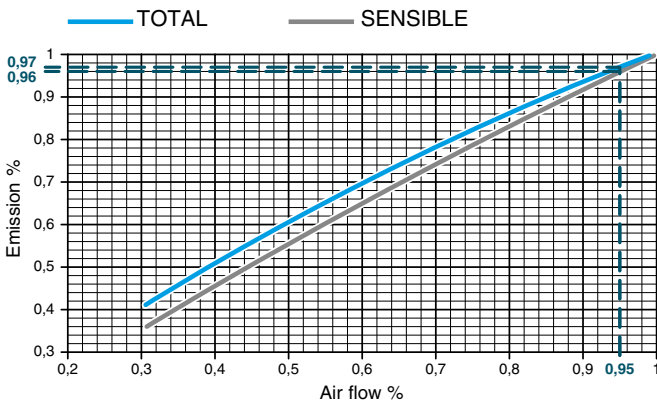

Correction diagram of heating emission depending on air flow

Diagram 2 - Heating emission

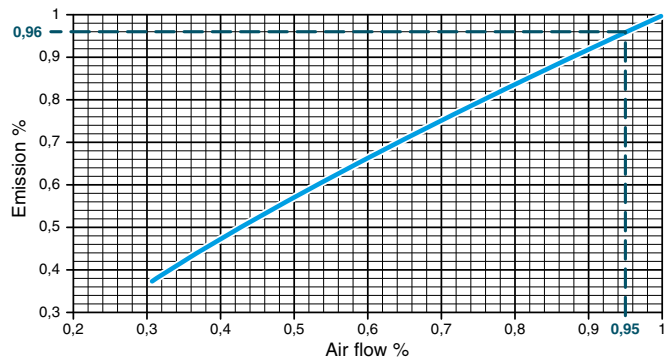

Calculation of the pressure drop:

From the **“Pressure drop” Diagram of DFCL 64** with 3400 m³/h of air flow, we can find the pressure drop of the unit:

- ΔP air for the coil 6+2 = **22 Pa**
 - ΔP air for the spigot plenum = **2 Pa**
- The calculation is:
- ΔP total air of **DFCL** = 22+2 = **24 Pa**

Total pressure drop:

- **Spigot pressure drop + DFCL pressure drop = 110 Pa + 24 Pa = 134 Pa**

Diagram for DFCL 64 “Pressure drop”

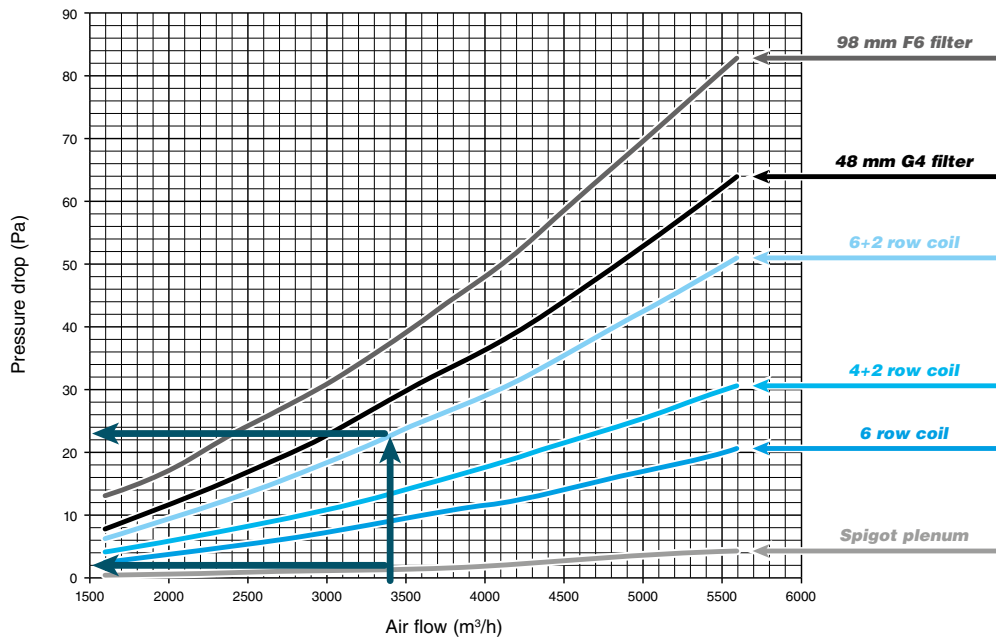

From the **“Available pressure” Diagram of DFCL 64** working at medium speed and with 3400 m³/h of air flow, we can find:

- **Available pressure = 140 Pa = ~ 134 Pa**

Diagram for DFCL 64 “Available pressure”

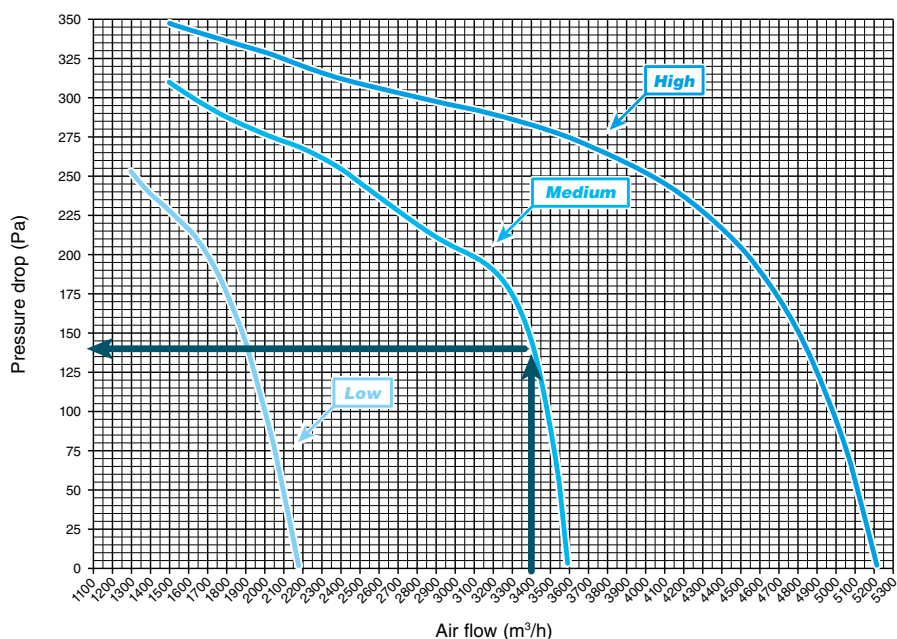

Power absorbed (Watt) depending on the variation of the air flow

DFCL 6

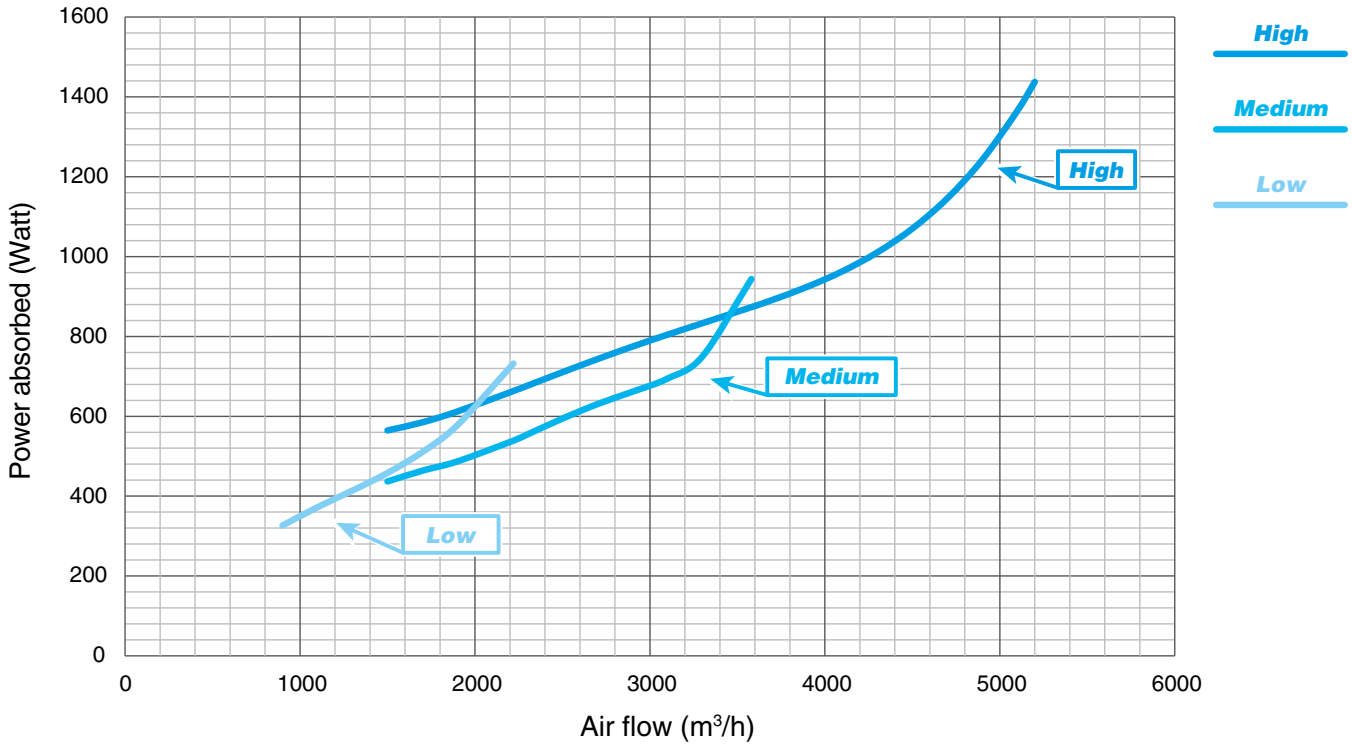

DFCL 7

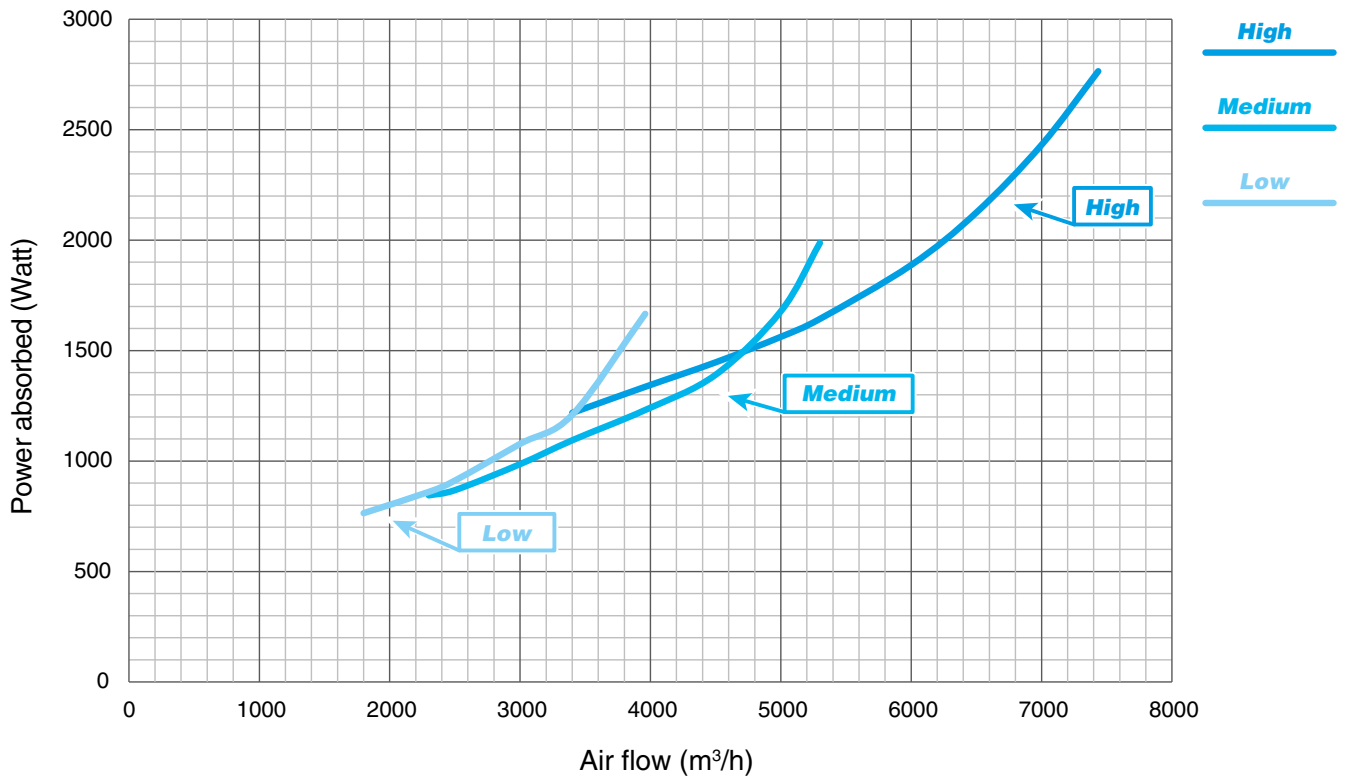

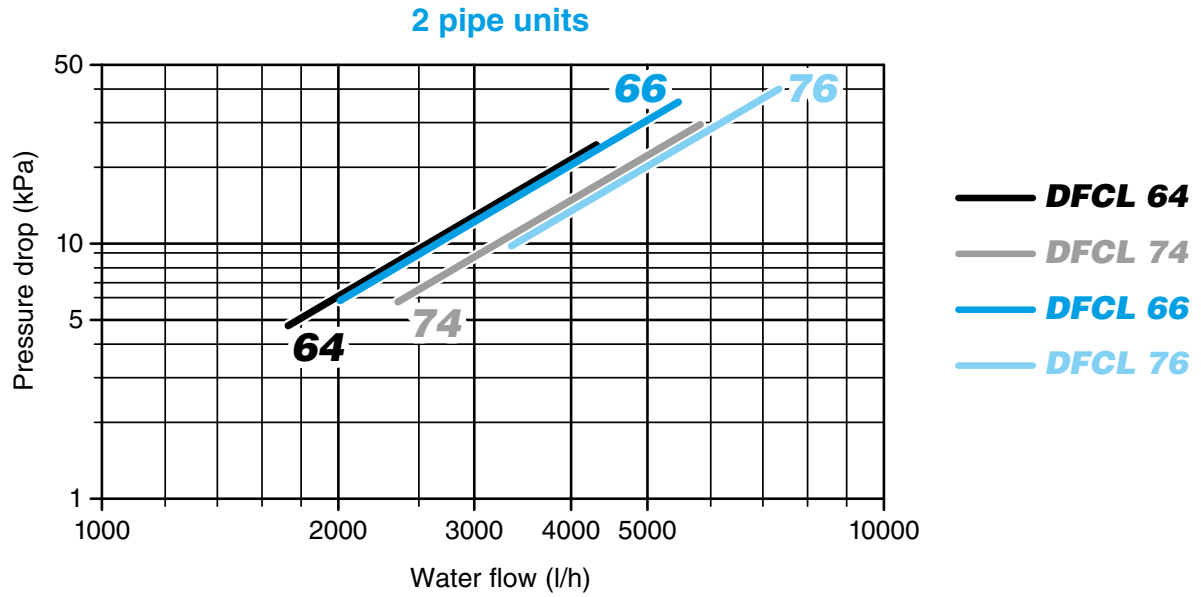

The water pressure drop figures refer to a mean water temperature of **10 °C**; for different temperatures, multiply the pressure drop figures by the correction factors **K**.

°C	20	30	40	50	60	70	80
K	0,94	0,90	0,86	0,82	0,78	0,74	0,70

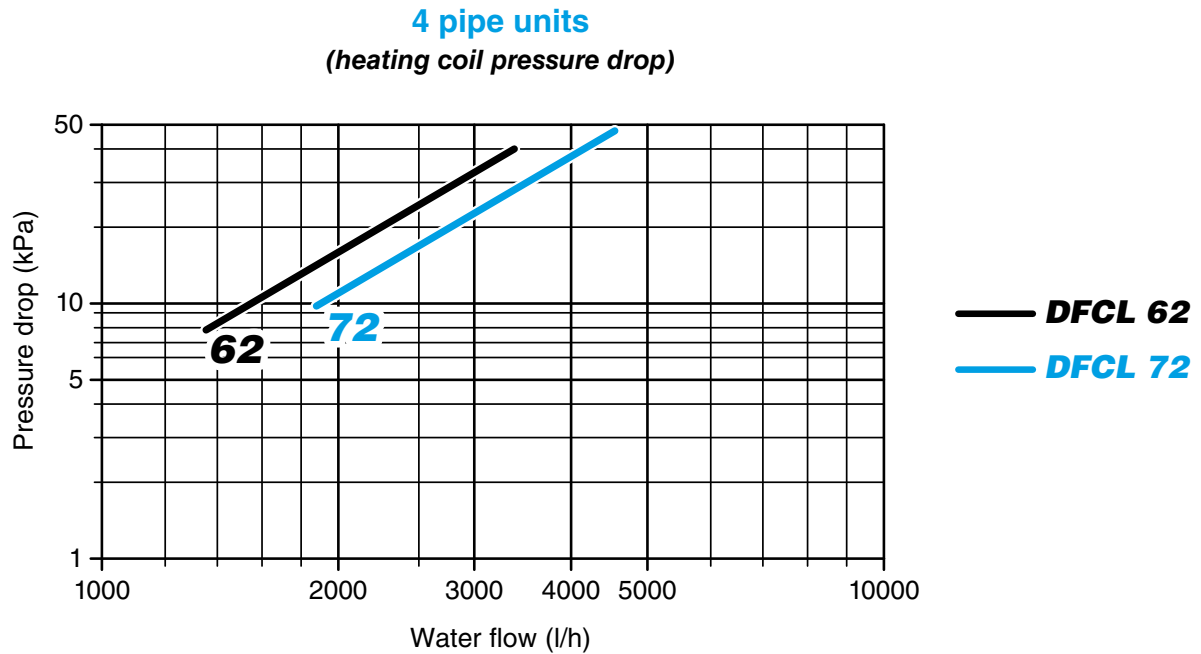

The water pressure drop figures refer to a mean water temperature of **65 °C**; for different temperatures, multiply the pressure drop figures by the correction factors **K**.

°C	40	50	60	70	80
K	1,14	1,08	1,02	0,96	0,90

DFCL 1÷7 | Wall electronic controls

IDENTIFICATION	CODE
WM-3V	9066642



Dimensions: 75x75x30 mm

For Models 1-2 use only the WM-3V control code 9066642.
For Models 3-4-5-6 use the WM-3V control code 9066642 + SEL-S code 9079110.
For Model 7 use the WM-3V control code 9066642 + 2 speed switches SEL-S code 9079110.

- ON-OFF switch and 3 speed switch, without thermostatic control.
- It does not control the valves.

IDENTIFICATION	CODE
WM-T	9066630E



Dimensions: 135x86x31 mm

For Models 1-2 use only the WM-T control code 9066630.
For Models 3-4-5-6 use the WM-T control code 9066630 + SEL-S code 9079110.
For Model 7 use the WM-T control code 9066630 + 2 speed switches SEL-S code 9079110.

- ON-OFF switch and manual 3 speed switch.
- Manual Summer/Winter switch.
- Electronic room thermostat for fan control (ON-OFF).
- Electronic room thermostat for water valve control (ON-OFF).
- It allows to control the low temperature cut-out thermostat (TMM).
- It allows to control the chilled water valve (ON-OFF) and the electric heater (BEM) only in case that hot water is not used in winter.
- Presence of a LED signal when the thermostat is on.

Control power absorption: 0,25 VA.

IDENTIFICATION	CODE
WM-TQR	9066631E



Dimensions: 135x86x31 mm

For Models 1-2 use only the WM-TQR control code 9066631.
For Models 3-4-5-6 use the WM-TQR control code 9066631 + SEL-S code 9079110.
For Model 7 use the WM-TQR control code 9066631 + 2 speed switches SEL-S code 9079110.

- ON-OFF switch and manual 3 speed switch.
- Manual, automatic or centralized Summer/Winter switch.
- Electric heater switch.
- Electronic room thermostat for fan control (ON-OFF).
- Electronic room thermostat for valve control (ON-OFF).
- Simultaneous thermostatic control of the valves and fan.
- It allows to control the low temperature cut-out thermostat (NTC).
- It allows to control the water valves (ON-OFF) and the electric heater managed as main heating element or as an integration element.
- Energy saving function.
- Presence of a LED signal when the thermostat is on.

Control power absorption: 1 VA.

IDENTIFICATION	CODE
COM	9053022

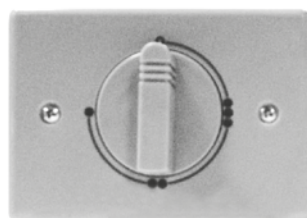

- Remote manual speed control.
- Commutator with 4 positions:
 - OFF
 - first speed
 - second speed
 - third speed

IDENTIFICATION	CODE
WM-AU	9066632E

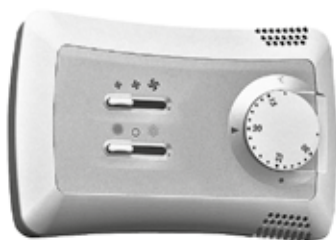

Dimensions: 135x86x24 mm

The control must always be connected with UPO-AU power unit (to be ordered separately).

- ON-OFF switch.
- Manual, automatic or centralized Summer/Winter switch.
- Manual or automatic 3 speed progressive switch.
- Summer/Winter/Fan/Auto mode switch.
- Electronic room thermostat for fan control (ON-OFF).
- Electronic room thermostat for valve control (ON-OFF).
- Simultaneous thermostatic control of the valves and fan.
- It allows to control the low temperature cut-out thermostat (NTC).
- Energy saving switch.
- Presence of a LED signal when the thermostat is on.

Control power absorption: see the UPO-AU power unit

IDENTIFICATION	CODE
T-MB	9066331E



Dimensions: 110x72x25 mm

The control must always be connected with UPO-AU power unit (to be ordered separately).

Wall control with display that allows controlling one or more units in Master/Slave mode. The control is equipped with internal sensor to detect the room temperature, which can be defined as a priority compared to the return air sensor on the fan coil.

The T-MB control features the following functions:

- Switch the unit ON and OFF.
- Temperature set.
- Manual, centralized or automatic Summer/Winter switch.
- Set the fan speed (low, medium, high or autofan).
- Set the operation mode (fan only, cooling, heating, auto).
- Possibility of use of the low temperature cut-out thermostat NTC mounted on the UPO-AU power unit.
- Time setting.
- Weekly ON/OFF program.

Control power absorption: see the UPO-AU power unit

DESCRIPTION	IDENTIFICATION	CODE
Power unit for WM-AU and T-MB remote controls for sizes 1, 2, fitted on the unit.	UPOM1-AU	9034170
Power unit for WM-AU and T-MB remote controls for sizes 3÷7, fitted on the unit.	UPOM3-AU	9034180
Power unit for WM-AU and T-MB remote controls for sizes 1, 2, not fitted on the unit.	UPO1-AU	9034169
Power unit for WM-AU and T-MB remote controls for sizes 3÷7, not fitted on the unit.	UPO3-AU	9034179



Power unit to be installed on the fan coil (fan coil interface).

- It controls the fan and the valves of the fan coil.
- It is connected to the electric supply.
- It receives the information required from the control.
- Possibility of use of the low temperature cut-out thermostat NTC:
 - T1 function for the return air control.
 - T2 function which controls the summer/winter switch.
 - T3 function as low temperature cut-out thermostat.
- It allows to control up to 10 units (1 master and 9 slaves).
- Max. Network length: 100 meters.
- Max cable length between control and first connected power unit: 20 meters.

Control power absorption: 2,3 VA

IDENTIFICATION	CODE
SEL-S	9079110



Speed switch (slave)

- It allows to control up to 8 units with only one centralized wall control (1 speed switch for each unit).
- For controls WM-3V, WM-T and WM-TQR.

Wall electronic control accessories

TMM low temperature cut-out thermostat

To be installed in contact with the hot water circuit.

To be used only with WM-T control.

For units working on heating only.

It stops the fan when the water temperature is lower than 30 °C and it starts the fan when is higher than 38 °C.



IDENTIFICATION	CODE
TMM	9053048

NTC low temperature cut-out thermostat

To be fitted between the coil fins; when connecting the control, the NTC probe cable must be separated from the power supply wires.

To be used only with WM-TQR control and the UPO-AU power-unit.

It stops the fan when the water temperature is lower than 28 °C and it starts the fan when is higher than 33 °C.

To use as:

- T1 function for the return air control.
- T2 function which controls the summer/winter switch.
- T3 function as low temperature cut-out thermostat.

IDENTIFICATION	CODE
NTC	3021090



T2 accessory

Type NTC sensor, to be placed on the water supply pipe upstream 3 way valves (not to be used with 2 way valves). The T2 sensor must be used as described below:

- Change-Over for the automatic switch of the operating mode. If water temperature is lower than 20 °C, cooling mode is set; on the other hand, if water temperature exceeds 30 °C, heating mode is set.

To be used with UPO-AU power-unit.

IDENTIFICATION	CODE
T2	9025310

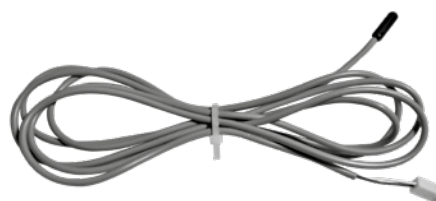

Change-Over CH 15-25

Automatic summer/winter switch to be installed in contact with the water circuit.

For 2-tube installations only (not to be used with 2 way valve).

To be used only with WM-TQR control.



IDENTIFICATION	CODE
CH 15-25	9053049

Following many years of experience in the field of heating and air conditioning, we have developed a range of **DFCL-ECM** fan coils for concealed installation and connection to a duct system.

The **DFCL-ECM units** supply a consistent air flow with static pressure up to 160 Pa to fit most conditions, with the combination of either 3 or 4 row heating coils and 2 or 4 pipe configurations with additional heating coil.

Compliant with Regulation (EU) No. 327/2011

Construction features

CASING

It is made with 1,0 mm galvanized steel for sizes 1-2-3 and with 1,2 mm galvanized steel for sizes 4-5, insulated with 10 mm polyolefin (PO) foam (class M1).

FAN ASSEMBLY

Consists of quiet centrifugal fans with two impellers directly driven to the motor.

ELECTRONIC MOTOR

Three phase permanent magnet brushless electronic motor that is controlled with current reconstructed according to a BLAC sinusoidal wave. The inverter board that controls the motor operation is powered by 230 Volt, single-phase and, with a switching system, it generates a three-phase frequency modulated, wave form power supply. The electric power supply required for the machine is therefore single-phase with voltage of 230V and frequency of 50-60Hz.

COIL

It is manufactured from drawn copper tube and the aluminium fins are mechanically bonded onto the tube by an expansion process.

The **DFCL-ECM** range is available with the combination of either 3 or 4 row coils with the possibility to add a 1 or 2 row coil (3+1, 4+1, 3+2, 4+2 versions for 4 pipe systems).

The connections are on the left hand side looking from the air inlet of the unit (see picture and drawing to the next page). On request the connections can be moved to the other side.

The heat exchanger is not suitable for use in corrosive atmosphere or in environments where aluminium may be subject to corrosion.

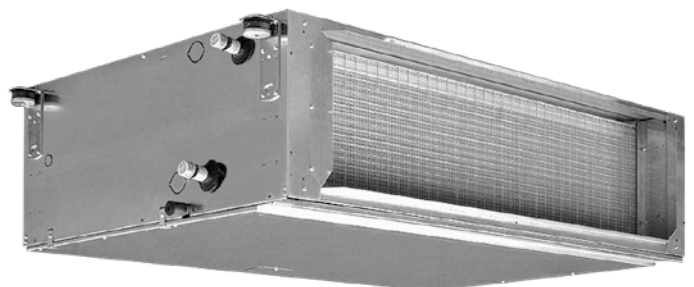

FILTER

The filter is made of polypropylene cellular fabric regenerating filter. The filter frame of galvanized steel is inserted into sliding guides fastened to the internal structure for easy insertion and removal of the filter.

CONDENSATE COLLECTION TRAY

It is made from galvanized steel insulated with 3 mm polyolefin (PO) foam (class M1).

Left connections (standard)

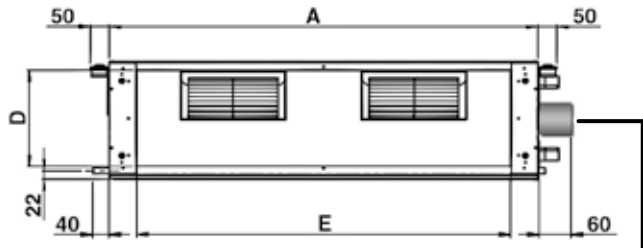
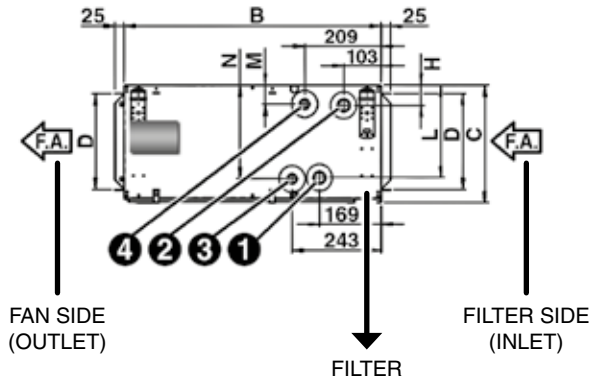

Right connections (on request)

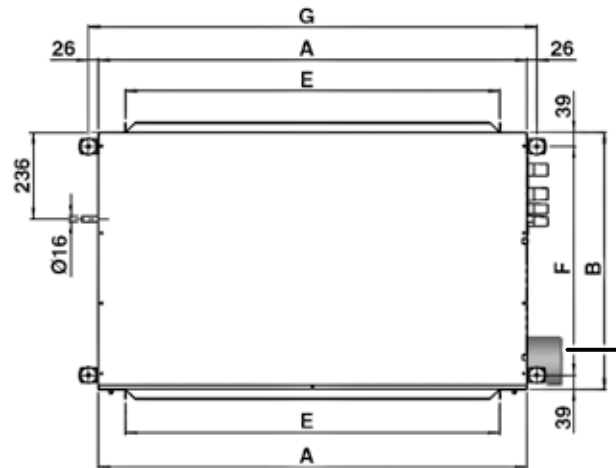
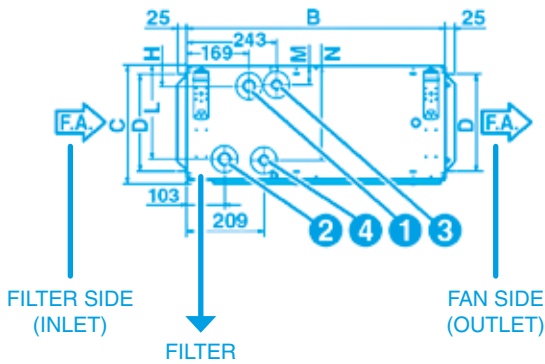

STANDARD

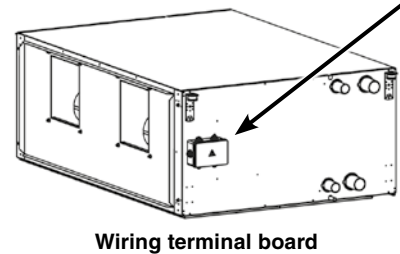
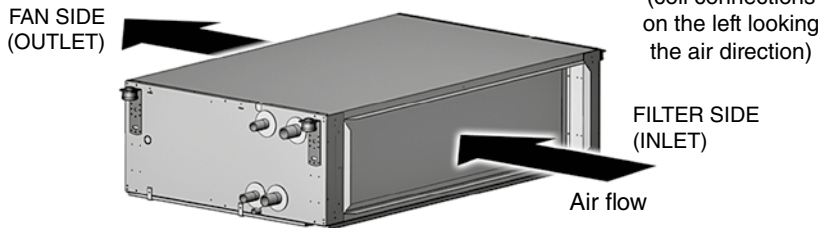

MODEL	Dimensions (mm)											Coil			
	A	B	C	D	E	F	G	H	L	M	N	Main		Additional	
												① IN	② OUT	③ IN	④ OUT
DFCL-ECM 1	1133	698	310	255	991	620	1185	54	245	50	249	3/4"	3/4"	3/4"	3/4"
DFCL-ECM 2	1133	698	310	255	991	620	1185	54	245	50	249	1"	1"	3/4"	3/4"
DFCL-ECM 3	1133	698	360	305	991	620	1185	54	295	50	299	1"	1"	3/4"	3/4"
DFCL-ECM 4	1445	853	360	293	1302	775	1497	58	291	54	295	1 1/4"	1 1/4"	1"	1"
DFCL-ECM 5	1445	853	435	368	1302	775	1497	58	367	54	370	1 1/4"	1 1/4"	1"	1"

MODEL	Weight without packaging (kg)						Weight with packaging (kg)						Water content (l)			
	3R	3+1R	3+2R	4R	4+1R	4+2R	3R	3+1R	3+2R	4R	4+1R	4+2R	3R	4R	1R	2R
DFCL-ECM 1	45	48	50	47	50	51	48	51	53	50	53	54	2,0	2,6	0,9	1,5
DFCL-ECM 2	46	50	52	48	51	53	49	53	55	51	54	56	2,9	3,7	1,1	1,8
DFCL-ECM 3	54	58	60	56	60	62	57	61	63	59	63	65	3,5	4,6	1,4	2,4
DFCL-ECM 4	75	80	83	78	83	86	79	84	87	82	87	90	4,7	6,0	2,0	3,2
DFCL-ECM 5	85	90	94	88	94	98	89	94	98	92	98	102	5,7	7,1	2,7	4,1

Water circuit	Maximum water pressure: 1000 kPa (10 bars)	MIN. entering water temperature: + 6 °C

		MAX. entering water temperature: + 80 °C
<hr/>		
		MIN. entering air temperature: + 6 °C

Air flow	Suitable relative humidity 15-75%	MAX. entering air temperature: + 40 °C

		MAX. leaving air temperature: + 50 °C
<hr/>		
Supply	Single phase 230V 50/60 Hz	
<hr/>		

Motor electrical data (max. absorption)

MODEL		DFCL-ECM 1	DFCL-ECM 2	DFCL-ECM 3	DFCL-ECM 4	DFCL-ECM 5
230/1 50Hz	W	165	375	545	530	1045
	A	1,15	1,70	2,40	2,35	4,60

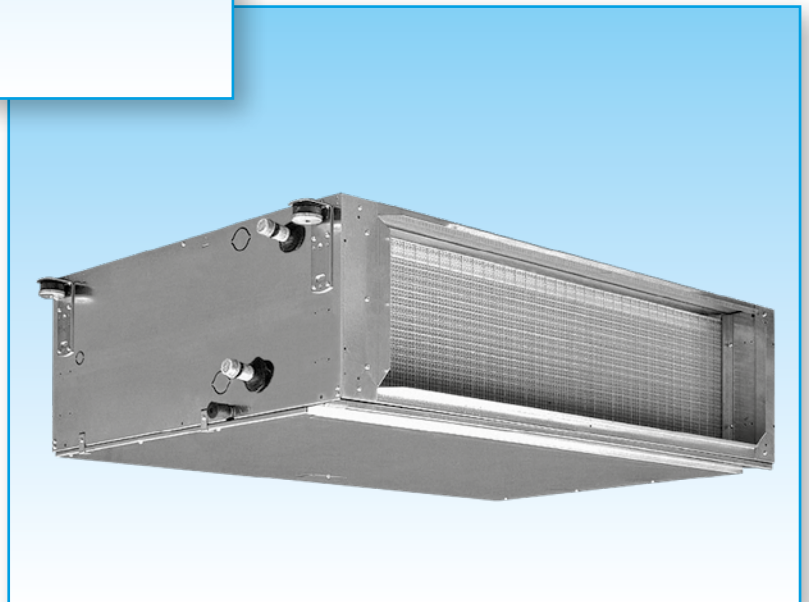
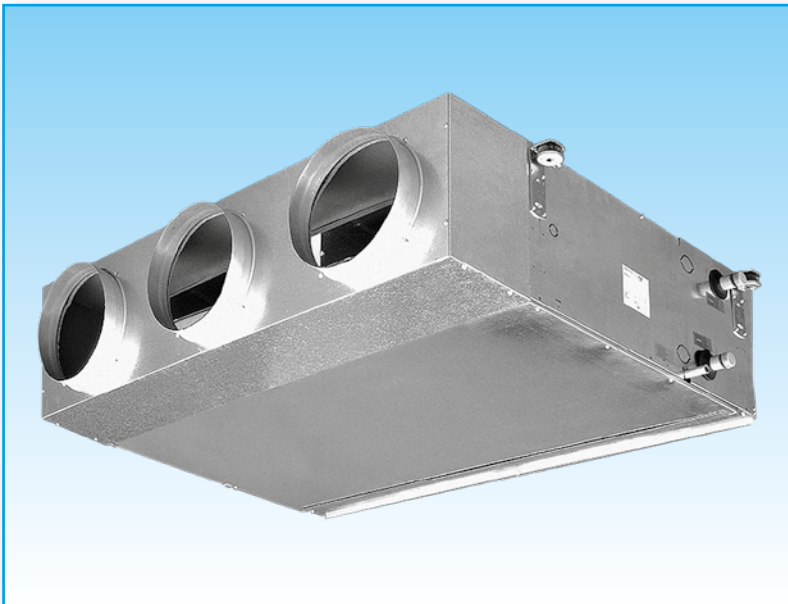

2 pipe units.

The following standard rating conditions are used:

COOLING (summer mode)

Entering air temperature +27 °C d.b. +19 °C b.u.
Water temperature + 7 °C E.W.T. +12 °C L.W.T.

HEATING (winter mode)

Entering air temperature +20 °C
Water temperature +45 °C E.W.T. +40 °C L.W.T.

MODEL		DFCL-ECM 14			DFCL-ECM 24			DFCL-ECM 34			DFCL-ECM 44			DFCL-ECM 54		
Inverter Power (V)	V	4,5	7	9	4	6	8	4,5	6,5	8	5,5	7,5	10	3	5	7
Speed		MIN	MED	MAX	MIN	MED	MAX	MIN	MED	MAX	MIN	MED	MAX	MIN	MED	MAX
Air flow	m³/h	780	1100	1310	940	1360	1780	1380	1950	2390	1840	2440	3080	2400	3320	3920
Available pressure	Pa	26	50	70	24	50	85	25	50	75	28	50	80	25	50	70
Cooling total emission	kW	4,14	5,11	5,61	5,44	6,86	7,94	7,87	9,70	10,81	10,47	12,39	13,99	13,73	16,70	18,17
Cooling sensible emission	kW	3,24	4,18	4,72	4,08	5,36	6,44	5,93	7,61	8,72	7,90	9,65	11,23	10,46	13,26	14,75
Heating	kW	5,18	6,80	7,76	6,42	8,64	10,62	8,64	11,25	13,06	12,13	15,15	18,08	15,90	20,51	23,25
Dp Cooling	kPa	4,9	7,2	8,7	7,7	11,8	15,8	11,7	17,4	21,6	12,2	16,9	21,7	12,3	17,9	21,4
Dp Heating	kPa	5,3	8,7	11,1	7,5	12,9	18,8	10,1	16,4	21,4	11,6	17,4	23,9	12,8	20,3	25,4
Fan	W	40	88	144	44	110	225	80	195	340	110	253	530	166	383	702
Sound power outlet	dB(A)	45	52	59	45	55	61	52	60	64	55	62	67	58	67	71
Sound power inlet + radiated	dB(A)	48	55	61	48	57	63	55	62	66	58	64	69	61	70	73
Sound pressure outlet (*)	dB(A)	36	43	50	36	46	52	43	51	55	46	53	58	49	58	62
Sound pressure inlet + radiated (*)	dB(A)	39	46	52	39	48	54	46	53	57	49	55	60	52	61	64
Codice Plenum		9034200			9034200			9034220			9034230			9034240		

4 pipe units.

The following standard rating conditions are used:

COOLING (summer mode)

Entering air temperature +27 °C d.b. +19 °C b.u.
Water temperature + 7 °C E.W.T. +12 °C L.W.T.

HEATING (winter mode)

Entering air temperature +20 °C
Water temperature +65 °C E.W.T. +55 °C L.W.T.

MODEL		DFCL-ECM 14+1			DFCL-ECM 24+1			DFCL-ECM 34+1			DFCL-ECM 44+1			DFCL-ECM 54+1		
Inverter Power (V)	V	4,5	7	9	4	6	8	4,5	6,5	8	5,5	7,5	10	3	5	7
Speed		MIN	MED	MAX	MIN	MED	MAX	MIN	MED	MAX	MIN	MED	MAX	MIN	MED	MAX
Air flow	m³/h	750	1040	1250	920	1340	1750	1350	1920	2350	1810	2400	3040	2380	3300	3860
Available pressure	Pa	26	50	72	24	50	85	25	50	75	28	50	80	26	50	68
Cooling total emission	kW	4,04	4,94	5,46	5,36	6,79	7,87	7,76	9,59	10,70	10,36	12,27	13,90	13,66	16,62	18,00
Cooling sensible emission	kW	3,14	4,01	4,55	4,01	5,30	6,35	5,83	7,51	8,61	7,79	9,53	11,13	10,39	13,19	14,58
Heating	kW	3,43	4,18	4,62	4,33	5,42	6,25	5,90	7,20	8,02	8,06	9,48	10,75	10,53	12,67	13,77
Dp Cooling	kPa	4,6	6,8	8,3	7,5	11,6	15,5	11,4	17,1	21,2	12,0	16,6	21,4	11,2	16,3	19,4
Dp Heating	kPa	9,4	13,4	16,0	13,6	20,4	26,4	9,9	14,3	17,3	19,6	26,3	33,0	18,5	25,7	29,9
Fan	W	40	88	144	44	115	225	80	200	340	110	253	530	168	384	695
Sound power outlet	dB(A)	45	52	59	45	55	61	52	60	64	55	62	67	58	67	71
Sound power inlet + radiated	dB(A)	48	55	61	48	57	63	55	62	66	58	64	69	61	70	73
Sound pressure outlet (*)	dB(A)	36	43	50	36	46	52	43	51	55	46	53	58	49	58	62
Sound pressure inlet + radiated (*)	dB(A)	39	46	52	39	48	54	46	53	57	49	55	60	52	61	64
Codice Plenum		9034200			9034200			9034220			9034230			9034240		

(*) = The sound pressure levels are 9 dB(A) lower than the sound power levels and apply to the reverberant field of a 100 m³ room and a reverberation time of 0.5 sec.

2 pipe units.

The following standard rating conditions are used:

COOLING (summer mode)

Entering air temperature +27 °C d.b. +19 °C b.u.
Water temperature + 7 °C E.W.T. +12 °C L.W.T.

HEATING (winter mode)

Entering air temperature +20 °C
Water temperature +45 °C E.W.T. +40 °C L.W.T.

AVAILABLE PRESSURE: 0 Pa

DFCL UNITS WITH 3 ROW COIL

MODEL		DFCL-ECM 13					DFCL-ECM 23					DFCL-ECM 33				
		1	3	5	7,5	10	1	3	5	7,5	10	1	3	5	7,5	10
Inverter Power (V)	V															
Air flow	m³/h	505	950	1280	1580	1800	640	970	1375	2030	2625	760	1190	1750	2565	3390
Cooling total emission	kW	3,00	4,05	4,78	5,33	5,69	3,70	4,82	5,91	7,22	8,12	4,54	6,05	7,57	9,21	10,41
Cooling sensible emission	kW	2,37	3,44	4,22	4,88	5,33	2,78	3,79	4,83	6,27	7,38	3,36	4,71	6,16	7,94	9,42
Heating	kW	3,42	4,93	6,08	7,01	7,63	3,97	5,46	7,05	9,23	10,92	4,75	6,71	8,89	11,57	13,88
Dp Cooling	kPa	4,5	7,8	10,7	13,1	14,9	6,4	10,4	15,1	22,3	28,6	6,6	11,1	16,9	24,8	32,4
Dp Heating	kPa	4,3	8,3	12,1	15,7	18,3	5,4	9,6	15,2	24,8	33,6	5,3	9,9	16,5	26,6	36,9
Fan	W	10	27	57	94	148	12	29	65	188	362	13	30	83	256	531
Sound power Lw	dB(A)	35	44	49	56	60	39	46	53	61	69	41	48	56	64	70
Sound pressure (*)	dB(A)	26	35	40	47	51	30	37	44	52	60	32	39	47	55	61

MODEL		DFCL-ECM 43					DFCL-ECM 53				
		1	3	5	7,5	10	1	3	5	7,5	10
Inverter Power (V)	V										
Air flow	m³/h	745	1275	1890	2730	3535	1495	2605	3580	4400	5160
Cooling total emission	kW	4,83	6,99	8,89	10,84	12,26	8,60	12,13	14,37	15,83	16,90
Cooling sensible emission	kW	3,48	5,29	7,01	8,98	10,56	6,52	9,93	12,16	13,86	15,22
Heating	kW	5,17	8,01	10,84	14,15	16,91	9,71	14,92	18,77	21,62	24,04
Dp Cooling	kPa	5,0	9,8	15,3	22,4	28,9	8,8	16,6	23,2	28,4	33,2
Dp Heating	kPa	3,2	7,2	12,4	20,2	27,8	8,8	19,3	29,2	37,8	45,9
Fan	W	12	30	76	219	484	41	139	340	636	1020
Sound power Lw	dB(A)	39	48	56	64	69	48	61	70	75	79
Sound pressure (*)	dB(A)	30	39	47	55	60	39	52	61	66	70

DFCL UNITS WITH 4 ROW COIL

MODEL		DFCL-ECM 14					DFCL-ECM 24					DFCL-ECM 34				
		1	3	5	7,5	10	1	3	5	7,5	10	1	3	5	7,5	10
Inverter Power (V)	V															
Air flow	m³/h	460	870	1190	1520	1750	620	930	1345	1980	2580	740	1170	1720	2525	3290
Cooling total emission	kW	2,90	4,46	5,39	6,17	6,64	4,09	5,42	6,85	8,50	9,67	5,13	7,09	9,08	11,24	12,79
Cooling sensible emission	kW	2,16	3,57	4,47	5,32	5,86	2,97	4,09	5,36	7,02	8,32	3,67	5,29	7,03	9,16	10,87
Heating	kW	3,33	5,65	7,22	8,67	9,59	4,51	6,36	8,56	11,48	13,90	5,19	7,57	10,23	13,59	16,36
Dp Cooling	kPa	2,5	5,5	7,8	10,1	11,6	4,5	7,6	11,7	17,6	23,0	5,3	9,6	15,1	22,9	29,9
Dp Heating	kPa	2,4	6,2	9,7	13,5	16,2	4,0	7,4	12,7	21,7	30,6	4,0	8,0	13,8	23,1	32,2
Fan	W	10	26	55	104	154	12	25	65	183	371	13	30	85	264	541
Sound power Lw	dB(A)	35	44	49	56	60	39	46	53	61	69	41	48	56	64	70
Sound pressure (*)	dB(A)	26	35	40	47	51	30	37	44	52	60	32	39	47	55	61

MODEL		DFCL-ECM 44					DFCL-ECM 54				
		1	3	5	7,5	10	1	3	5	7,5	10
Inverter Power (V)	V										
Air flow	m³/h	730	1250	1860	2690	3475	1480	2580	3550	4355	5095
Cooling total emission	kW	5,39	8,09	10,58	13,18	15,06	9,89	14,43	17,43	19,41	20,88
Cooling sensible emission	kW	3,78	5,91	7,99	10,42	12,33	7,21	11,24	14,00	16,07	17,73
Heating	kW	5,53	8,81	12,24	16,33	19,76	10,64	16,85	21,58	25,12	28,13
Dp Cooling	kPa	3,6	7,5	12,3	18,8	24,6	6,7	13,5	19,3	23,9	28,1
Dp Heating	kPa	2,8	6,5	11,8	19,9	28,1	6,2	14,2	22,2	29,2	35,9
Fan	W	12	30	78	226	505	41	144	346	644	1031
Sound power Lw	dB(A)	39	48	56	64	69	48	61	70	75	79
Sound pressure (*)	dB(A)	30	39	47	55	60	39	52	61	66	70

(*) = The sound pressure levels are 9 dB(A) lower than the sound power levels and apply to the reverberant field of a 100 m³ room and a reverberation time of 0.5 sec.

DFCL-ECM 1÷5 | Main performance and technical characteristics

4 pipe units.

The following standard rating conditions are used:

COOLING (summer mode)

Entering air temperature +27 °C d.b. +19 °C b.u.
Water temperature + 7 °C E.W.T. +12 °C L.W.T.

HEATING (winter mode)

Entering air temperature +20 °C
Water temperature +65 °C E.W.T. +55 °C L.W.T.

AVAILABLE PRESSURE: 0 Pa

DFCL UNITS WITH 3+1 ROW COIL

MODEL		DFCL-ECM 13+1					DFCL-ECM 23+1					DFCL-ECM 33+1				
		1	3	5	7,5	10	1	3	5	7,5	10	1	3	5	7,5	10
Inverter Power (V)	V															
Air flow	m³/h	460	870	1190	1520	1750	620	930	1345	1980	2580	740	1170	1720	2525	3290
Cooling total emission	kW	2,57	3,83	4,58	5,18	5,55	3,62	4,70	5,83	7,12	8,03	4,45	5,98	7,49	9,11	10,22
Cooling sensible emission	kW	1,98	3,21	3,99	4,71	5,17	2,71	3,68	4,76	6,16	7,27	3,29	4,65	6,08	7,83	9,19
Heating	kW	2,51	3,76	4,50	5,13	5,52	3,36	4,35	5,43	6,67	7,61	4,03	5,40	6,78	8,31	9,50
Dp Cooling	kPa	3,4	7,1	9,8	12,6	14,4	6,1	9,9	14,8	21,9	28,1	6,4	10,9	16,6	24,5	31,5
Dp Heating	kPa	5,3	11,1	15,3	19,3	22,1	8,6	13,8	20,5	29,7	37,5	5,0	8,5	12,9	18,5	23,4
Fan	W	10	26	55	104	154	12	25	65	183	371	13	30	85	264	541
Sound power Lw	dB(A)	35	44	49	56	60	39	46	53	61	69	41	48	56	64	70
Sound pressure (*)	dB(A)	26	35	40	47	51	30	37	44	52	60	32	39	47	55	61

MODEL		DFCL-ECM 43+1					DFCL-ECM 53+1				
		1	3	5	7,5	10	1	3	5	7,5	10
Inverter Power (V)	V										
Air flow	m³/h	730	1250	1860	2690	3475	1480	2580	3550	4355	5095
Cooling total emission	kW	4,76	6,91	8,81	10,75	12,12	8,54	12,04	14,31	15,74	16,80
Cooling sensible emission	kW	3,43	5,22	6,92	8,89	10,40	6,47	9,85	12,09	13,75	15,08
Heating	kW	4,50	6,39	8,20	10,07	11,52	7,79	11,05	13,17	14,69	15,93
Dp Cooling	kPa	4,9	9,6	15,1	22,1	28,5	8,7	16,5	23,0	28,2	32,9
Dp Heating	kPa	6,8	12,9	20,2	29,4	37,4	10,7	20,1	27,6	33,6	38,8
Fan	W	12	30	78	226	505	41	144	346	644	1031
Sound power Lw	dB(A)	39	48	56	64	69	48	61	70	75	79
Sound pressure (*)	dB(A)	30	39	47	55	60	39	52	61	66	70

DFCL UNITS WITH 4+1 ROW COIL

MODEL		DFCL-ECM 14+1					DFCL-ECM 24+1					DFCL-ECM 34+1				
		1	3	5	7,5	10	1	3	5	7,5	10	1	3	5	7,5	10
Inverter Power (V)	V															
Air flow	m³/h	420	810	1130	1475	1710	600	900	1320	1945	2542	710	1150	1690	2492	3215
Cooling total emission	kW	2,71	4,26	5,22	6,06	6,54	4,00	5,30	6,77	8,40	9,59	4,97	7,00	8,97	11,15	12,61
Cooling sensible emission	kW	2,00	3,38	4,29	5,19	5,75	2,89	3,99	5,28	6,92	8,23	3,54	5,21	6,93	9,07	10,67
Heating	kW	2,36	3,60	4,37	5,05	5,45	3,29	4,27	5,38	6,61	7,55	3,92	5,34	6,73	8,26	9,38
Dp Cooling	kPa	2,2	5,1	7,4	9,8	11,5	4,3	7,3	11,4	17,3	22,6	5,0	9,4	14,8	22,6	29,2
Dp Heating	kPa	4,8	10,2	14,5	18,8	21,6	8,3	13,3	20,1	29,2	37,0	4,8	8,3	12,6	18,3	23,0
Fan	W	10	25	64	117	158	12	25	66	182	377	13	31	87	268	544
Sound power Lw	dB(A)	35	44	49	56	60	39	46	53	61	69	41	48	56	64	70
Sound pressure (*)	dB(A)	26	35	40	47	51	30	37	44	52	60	32	39	47	55	61

MODEL		DFCL-ECM 44+1					DFCL-ECM 54+1				
		1	3	5	7,5	10	1	3	5	7,5	10
Inverter Power (V)	V										
Air flow	m³/h	720	1230	1835	2660	3425	1460	2555	3525	4315	5045
Cooling total emission	kW	5,33	8,00	10,48	13,10	14,92	9,79	14,34	17,35	19,31	20,74
Cooling sensible emission	kW	3,74	5,83	7,91	10,33	12,19	7,13	11,16	13,91	15,95	17,58
Heating	kW	4,45	6,32	8,13	10,02	11,43	7,72	11,00	13,12	14,62	15,85
Dp Cooling	kPa	3,5	7,4	12,1	18,6	24,2	6,0	12,2	17,6	21,8	25,6
Dp Heating	kPa	6,7	12,7	19,9	29,1	36,8	10,5	20,0	27,4	33,3	38,5
Fan	W	13	31	79	231	518	41	148	355	650	1036
Sound power Lw	dB(A)	39	48	56	64	69	48	61	70	75	79
Sound pressure (*)	dB(A)	30	39	47	55	60	39	52	61	66	70

(*) = The sound pressure levels are 9 dB(A) lower than the sound power levels and apply to the reverberant field of a 100 m³ room and a reverberation time of 0.5 sec.

4 pipe units.

The following standard rating conditions are used:

COOLING (summer mode)

Entering air temperature +27 °C d.b. +19 °C b.u.
 Water temperature + 7 °C E.W.T. +12 °C L.W.T.

HEATING (winter mode)

Entering air temperature +20 °C
 Water temperature +65 °C E.W.T. +55 °C L.W.T.

AVAILABLE PRESSURE: 0 Pa

DFCL UNITS WITH 4+2 ROW COIL

MODEL		DFCL-ECM 14+2					DFCL-ECM 24+2					DFCL-ECM 34+2				
		1	3	5	7,5	10	1	3	5	7,5	10	1	3	5	7,5	10
Inverter Power (V)	V															
Air flow	m³/h	400	740	1055	1405	1650	570	865	1285	1895	2485	690	1125	1645	2441	3120
Cooling total emission	kW	2,65	4,08	5,11	6,00	6,54	3,90	5,24	6,78	8,45	9,68	4,86	6,90	8,82	11,01	12,42
Cooling sensible emission	kW	1,94	3,20	4,16	5,10	5,71	2,80	3,92	5,26	6,92	8,27	3,46	5,12	6,79	8,93	10,45
Heating	kW	4,49	7,16	9,16	11,07	12,26	6,37	8,75	11,61	15,03	17,83	7,69	11,13	14,57	18,89	22,02
Dp Cooling	kPa	2,1	4,7	7,1	9,6	11,4	4,1	7,1	11,4	17,5	23,0	4,8	9,1	14,4	22,1	28,4
Dp Heating	kPa	3,2	7,4	11,6	16,3	19,6	7,0	12,5	20,9	33,4	45,5	3,8	7,4	12,0	19,3	25,4
Fan	W	9	24	52	110	164	12	26	67	182	382	13	31	89	274	542
Sound power Lw	dB(A)	35	44	49	56	60	39	46	53	61	69	41	48	56	64	70
Sound pressure (*)	dB(A)	26	35	40	47	51	30	37	44	52	60	32	39	47	55	61

MODEL		DFCL-ECM 44+2					DFCL-ECM 54+2				
		1	3	5	7,5	10	1	3	5	7,5	10
Inverter Power (V)	V										
Air flow	m³/h	700	1200	1800	2612	3355	1450	2525	3485	4260	4970
Cooling total emission	kW	5,21	7,85	10,34	12,96	14,75	9,74	14,22	17,22	19,13	20,56
Cooling sensible emission	kW	3,65	5,72	7,78	10,19	12,00	7,09	11,06	13,78	15,77	17,38
Heating	kW	8,35	12,75	17,20	22,18	26,11	15,42	23,10	28,66	32,65	35,93
Dp Cooling	kPa	2,8	5,9	9,9	15,1	19,7	6,0	12,0	17,4	21,5	25,2
Dp Heating	kPa	5,6	12,0	20,6	32,8	44,1	9,6	19,9	29,5	37,3	44,4
Fan	W	13	32	81	237	529	42	152	363	656	1042
Sound power Lw	dB(A)	39	48	56	64	69	48	61	70	75	79
Sound pressure (*)	dB(A)	30	39	47	55	60	39	52	61	66	70

(*) = The sound pressure levels are 9 dB(A) lower than the sound power levels and apply to the reverberant field of a 100 m³ room and a reverberation time of 0.5 sec.

Cooling emission of 3 row DFCL-ECM coil

Entering air temperature: 27 °C – R. H.: 50% – AVAILABLE PRESSURE: 0 Pa

MODEL	Vdc	WT: 7/12 °C					WT: 8/13 °C					WT: 10/15 °C				WT: 12/17 °C			
		Qv	Pc	Ps	Qw	Dp(c)	Pc	Ps	Qw	Dp(c)	Pc	Ps	Qw	Dp(c)	Pc	Ps	Qw	Dp(c)	
		m ³ /h	kW	kW	l/h	kPa	kW	kW	l/h	kPa	kW	kW	l/h	kPa	kW	kW	l/h	kPa	
DFCL-ECM 13	10	1800	6,19	5,16	1064	16,7	5,49	5,03	944	13,8	4,46	4,46	768	9,1	3,52	3,52	605	5,9	
	7,5	1580	5,95	4,81	1024	14,8	5,20	4,63	895	12,1	4,15	4,15	714	8,0	3,25	3,25	559	5,1	
	5	1280	5,32	4,15	914	12,1	4,65	3,98	800	9,9	3,67	3,67	632	6,4	2,86	2,86	491	4,0	
	3	950	4,40	3,35	757	9,0	3,93	3,24	676	7,3	3,08	3,04	530	4,6	2,36	2,34	406	2,8	
	1	505	3,27	2,34	562	5,2	2,91	2,23	500	4,2	2,25	2,03	386	2,6	1,69	1,67	291	1,6	
DFCL-ECM 23	10	2625	9,31	7,46	1602	31,9	8,14	7,20	1400	26,4	6,55	6,55	1127	17,7	5,18	5,18	892	11,5	
	7,5	2030	7,93	6,14	1363	25,3	7,13	6,02	1226	20,7	5,68	5,68	977	13,6	4,45	4,45	765	8,7	
	5	1375	6,42	4,72	1105	17,3	5,75	4,57	989	14,1	4,53	4,30	779	9,0	3,49	3,49	600	5,6	
	3	970	5,24	3,74	901	11,9	4,69	3,58	806	9,7	3,65	3,31	627	6,1	2,77	2,75	477	3,7	
	1	640	4,03	2,76	693	7,4	3,60	2,61	619	6,0	2,78	2,36	478	3,7	2,08	2,05	358	2,2	
DFCL-ECM 33	10	3390	11,63	9,36	2000	36,2	10,51	9,25	1808	30,0	8,46	8,46	1456	20,1	6,71	6,71	1154	13,0	
	7,5	2565	10,12	7,78	1741	28,1	9,11	7,63	1567	23,1	7,25	7,25	1247	15,2	5,69	5,69	978	9,7	
	5	1750	8,24	6,02	1417	19,4	7,38	5,83	1269	15,8	5,81	5,48	999	10,2	4,48	4,48	771	6,3	
	3	1190	6,57	4,65	1130	12,8	5,87	4,43	1010	10,4	4,57	4,09	787	6,6	3,48	3,44	598	4,0	
	1	760	4,92	3,35	847	7,6	4,41	3,16	759	6,2	3,41	2,85	586	3,9	2,55	2,51	438	2,3	
DFCL-ECM 43	10	3535	13,60	10,46	2339	32,7	12,25	10,28	2107	26,9	9,80	9,80	1685	17,8	7,69	7,69	1323	11,3	
	7,5	2730	11,90	8,84	2046	25,5	10,67	8,59	1835	21,0	8,46	8,18	1455	13,6	6,57	6,57	1130	8,5	
	5	1890	9,67	6,90	1664	17,6	8,67	6,62	1490	14,3	6,78	6,17	1166	9,1	5,19	5,19	893	5,6	
	3	1275	7,60	5,26	1306	11,3	6,80	4,99	1169	9,2	5,27	4,55	907	5,8	3,98	3,93	684	3,4	
	1	745	5,23	3,49	899	5,8	4,70	3,28	809	4,7	3,63	2,93	624	2,9	2,69	2,63	463	1,7	
DFCL-ECM 53	10	5160	19,16	15,44	3295	37,3	17,24	15,14	2966	30,8	13,82	13,82	2377	20,4	10,87	10,87	1869	13,1	
	7,5	4400	17,64	13,85	3034	32,3	15,87	13,53	2730	26,5	12,63	12,63	2172	17,3	9,88	9,88	1700	11,0	
	5	3580	15,81	12,02	2719	26,4	14,19	11,68	2441	21,6	11,22	11,22	1930	14,0	8,70	8,70	1497	8,7	
	3	2605	13,24	9,78	2277	19,2	11,84	9,42	2037	15,6	9,28	8,76	1596	9,9	7,10	7,09	1221	6,0	
	1	1495	9,38	6,49	1614	10,2	8,37	6,15	1439	8,3	6,47	5,56	1114	5,2	4,86	4,80	835	3,0	

Cooling emission of 3 row DFCL-ECM coil

Entering air temperature: 26 °C – R. H.: 50% – AVAILABLE PRESSURE: 0 Pa

MODEL	Vdc	WT: 7/12 °C					WT: 8/13 °C					WT: 10/15 °C				WT: 12/17 °C			
		Qv	Pc	Ps	Qw	Dp(c)	Pc	Ps	Qw	Dp(c)	Pc	Ps	Qw	Dp(c)	Pc	Ps	Qw	Dp(c)	
		m ³ /h	kW	kW	l/h	kPa	kW	kW	l/h	kPa	kW	kW	l/h	kPa	kW	kW	l/h	kPa	
DFCL-ECM 13	10	1800	5,53	5,04	951	13,8	4,98	4,98	857	11,2	3,97	3,97	683	7,4	3,45	3,45	593	5,7	
	7,5	1580	5,18	4,61	891	12,2	4,64	4,52	798	9,9	3,68	3,68	633	6,4	3,18	3,18	547	4,9	
	5	1280	4,62	3,97	795	9,9	4,13	3,87	710	8,0	3,25	3,25	559	5,1	2,68	2,68	461	3,6	
	3	950	3,91	3,23	673	7,3	3,47	3,12	597	5,8	2,70	2,67	465	3,7	2,06	2,05	355	2,2	
	1	505	2,89	2,23	498	4,2	2,56	2,13	440	3,3	1,96	1,93	337	2,0	1,47	1,45	252	1,2	
DFCL-ECM 23	10	2625	8,10	7,16	1393	26,3	7,33	7,09	1260	21,7	5,84	5,84	1004	14,4	4,83	4,83	830	10,2	
	7,5	2030	7,09	6,00	1220	20,7	6,35	5,87	1092	16,9	5,04	5,04	866	11,0	3,92	3,92	675	6,9	
	5	1375	5,73	4,57	986	14,0	5,10	4,42	877	11,4	3,98	3,98	685	7,2	3,05	3,05	525	4,4	
	3	970	4,66	3,58	801	9,6	4,13	3,43	711	7,7	3,19	3,15	548	4,8	2,41	2,39	414	2,9	
	1	640	3,57	2,62	615	6,0	3,16	2,48	544	4,8	2,41	2,25	415	2,9	1,80	1,77	309	1,7	
DFCL-ECM 33	10	3390	10,46	9,21	1799	29,9	9,40	9,08	1617	24,6	7,55	7,55	1298	16,3	6,10	6,10	1050	11,2	
	7,5	2565	9,06	7,61	1559	23,1	8,12	7,45	1397	18,8	6,43	6,43	1106	12,2	5,01	5,01	861	7,7	
	5	1750	7,34	5,82	1263	15,7	6,55	5,64	1126	12,7	5,11	5,11	879	8,1	3,93	3,93	675	4,9	
	3	1190	5,85	4,44	1006	10,4	5,19	4,25	892	8,3	4,00	3,92	688	5,2	3,02	2,99	520	3,1	
	1	760	4,39	3,17	754	6,2	3,88	3,00	667	4,9	2,95	2,71	508	3,0	2,19	2,16	378	1,7	
DFCL-ECM 43	10	3535	12,20	10,25	2099	26,8	10,95	10,06	1883	21,9	8,70	8,70	1496	14,3	6,79	6,79	1168	9,1	
	7,5	2730	10,61	8,57	1826	20,8	9,49	8,35	1632	16,9	7,47	7,47	1284	10,9	5,76	5,76	992	6,7	
	5	1890	8,61	6,61	1481	14,2	7,67	6,38	1319	11,5	5,94	5,94	1022	7,2	4,52	4,52	778	4,3	
	3	1275	6,76	4,99	1163	9,2	5,99	4,76	1030	7,3	4,59	4,35	790	4,5	3,45	3,41	593	2,6	
	1	745	4,67	3,29	804	4,7	4,13	3,10	711	3,7	3,14	2,77	540	2,3	2,31	2,27	397	1,3	
DFCL-ECM 53	10	5160	17,15	15,07	2950	30,7	15,44	14,79	2655	25,2	12,29	12,29	2114	16,5	10,08	10,08	1733	11,6	
	7,5	4400	15,79	13,48	2716	26,3	14,16	13,17	2435	21,5	11,19	11,19	1925	13,9	8,71	8,71	1498	8,8	
	5	3580	14,12	11,65	2428	21,5	12,60	11,30	2168	17,4	9,90	9,90	1703	11,2	7,63	7,63	1313	6,9	
	3	2605	11,78	9,41	2026	15,5	10,48	9,06	1803	12,5	8,13	8,11	1399	7,8	6,19	6,20	1064	4,7	
	1	1495	8,33	6,16	1432	8,2	7,36	5,84	1266	6,6	5,62	5,29	967	4,0	4,19	4,15	720	2,3	

Note: the power absorption (Watt) at page 50 must be subtracted from the total and sensible cooling emission.

Cooling emission of 3 row **DFCL-ECM** coil

Entering air temperature: 25 °C – R. H.: 50% – AVAILABLE PRESSURE: 0 Pa

MODEL	Vdc	Qv m³/h	WT: 7/12 °C				WT: 8/13 °C				WT: 10/15 °C				WT: 12/17 °C			
			Pc kW	Ps kW	Qw l/h	Dp(c) kPa	Pc kW	Ps kW	Qw l/h	Dp(c) kPa	Pc kW	Ps kW	Qw l/h	Dp(c) kPa	Pc kW	Ps kW	Qw l/h	Dp(c) kPa
DFCL-ECM 13	10	1800	4,96	4,96	854	11,2	4,45	4,45	765	9,1	3,53	3,53	607	5,9	3,09	3,09	532	4,7
	7,5	1580	4,63	4,50	797	9,9	4,13	4,13	711	8,0	3,26	3,26	561	5,2	2,85	2,85	491	4,1
	5	1280	4,12	3,85	708	8,0	3,66	3,66	629	6,4	2,86	2,86	493	4,1	2,50	2,50	429	3,2
	3	950	3,46	3,11	595	5,8	3,06	3,01	527	4,7	2,37	2,35	407	2,9	2,05	2,04	353	2,2
	1	505	2,55	2,12	438	3,3	2,24	2,03	385	2,6	1,70	1,67	292	1,6	1,45	1,43	250	1,2
DFCL-ECM 23	10	2625	7,28	7,03	1252	21,7	6,53	6,53	1122	17,7	5,20	5,20	894	11,6	4,53	4,53	779	9,0
	7,5	2030	6,34	5,85	1090	16,9	5,66	5,66	973	13,7	4,46	4,46	767	8,8	3,86	3,86	664	6,8
	5	1375	5,09	4,41	875	11,3	4,51	4,27	776	9,1	3,50	3,50	602	5,7	2,99	2,99	515	4,3
	3	970	4,12	3,43	708	7,7	3,63	3,29	625	6,1	2,78	2,76	479	3,7	2,34	2,32	402	2,7
	1	640	3,15	2,48	542	4,7	2,77	2,36	476	3,7	2,09	2,06	359	2,2	1,58	1,56	272	1,3
DFCL-ECM 33	10	3390	9,39	9,04	1615	24,6	8,44	8,44	1451	20,1	6,72	6,72	1157	13,2	5,86	5,86	1007	10,3
	7,5	2565	8,10	7,42	1393	18,7	7,23	7,23	1244	15,3	5,70	5,70	981	9,8	4,93	4,93	848	7,5
	5	1750	6,53	5,62	1123	12,7	5,79	5,44	995	10,2	4,50	4,50	773	6,4	3,84	3,84	661	4,8
	3	1190	5,16	4,25	888	8,3	4,56	4,07	784	6,6	3,49	3,45	600	4,0	2,83	2,81	487	2,8
	1	760	3,86	3,00	664	4,9	3,39	2,85	583	3,9	2,56	2,52	440	2,3	1,89	1,86	325	1,3
DFCL-ECM 43	10	3535	10,91	10,01	1876	21,9	9,75	9,75	1678	17,8	7,71	7,71	1326	11,5	6,65	6,65	1144	8,8
	7,5	2730	9,46	8,32	1626	16,9	8,42	8,10	1447	13,6	6,58	6,58	1132	8,6	5,63	5,63	969	6,5
	5	1890	7,63	6,36	1312	11,5	6,75	6,13	1162	9,1	5,21	5,21	896	5,7	4,38	4,38	753	4,1
	3	1275	5,96	4,76	1026	7,3	5,25	4,54	903	5,8	3,99	3,94	687	3,5	3,02	2,99	520	2,1
	1	745	4,11	3,11	707	3,7	3,61	2,93	620	2,9	2,70	2,62	465	1,7	1,98	1,95	340	1,0
DFCL-ECM 53	10	5160	15,38	14,71	2645	25,1	13,77	13,77	2368	20,5	10,90	10,90	1875	13,3	9,58	9,58	1648	10,5
	7,5	4400	14,10	13,11	2426	21,4	12,58	12,58	2164	17,4	9,91	9,91	1704	11,2	8,67	8,67	1491	8,8
	5	3580	12,57	11,27	2162	17,4	11,17	10,93	1922	14,0	8,73	8,73	1501	8,9	7,60	7,60	1307	6,9
	3	2605	10,43	9,04	1795	12,4	9,24	8,70	1590	9,9	7,12	7,11	1224	6,1	6,14	6,15	1055	4,7
	1	1495	7,33	5,85	1261	6,6	6,44	5,55	1108	5,2	4,87	4,82	838	3,1	3,80	3,76	653	2,0

Note: the power absorption (Watt) at page 50 must be subtracted from the total and sensible cooling emission.

LEGEND

- WT = Water temperature
- Pc = Cooling total emission
- Ps = Cooling sensible emission
- Qw = Water flow
- Dp(c) = Water pressure drop
- Speed = Fan speed
- MAX = High speed
- MED = Medium speed
- MIN = Low speed
- Qv = Air flow

Cooling emission of 4 row DFCL-ECM coil

Entering air temperature: 27 °C – R. H.: 50% – AVAILABLE PRESSURE: 0 Pa

MODEL	Vdc	Qv m ³ /h	WT: 7/12 °C				WT: 8/13 °C				WT: 10/15 °C				WT: 12/17 °C			
			Pc kW	Ps kW	Qw l/h	Dp(c) kPa	Pc kW	Ps kW	Qw l/h	Dp(c) kPa	Pc kW	Ps kW	Qw l/h	Dp(c) kPa	Pc kW	Ps kW	Qw l/h	Dp(c) kPa
DFCL-ECM 14	10	1750	7,28	5,77	1252	13,3	6,53	5,61	1124	10,9	5,15	5,15	886	7,0	3,99	3,99	687	4,4
	7,5	1520	6,75	5,23	1161	11,6	6,04	5,06	1038	9,4	4,75	4,75	817	6,0	3,66	3,66	629	3,7
	5	1190	5,89	4,40	1013	9,0	5,26	4,23	904	7,3	4,09	3,92	704	4,6	3,12	3,12	537	2,8
	3	870	4,87	3,53	838	6,4	4,34	3,37	746	5,2	3,35	3,08	577	3,2	2,53	2,50	435	1,9
	1	460	3,17	2,16	546	2,9	2,82	2,03	485	2,4	2,16	1,81	372	1,5	1,60	1,58	275	0,8
DFCL-ECM 24	10	2580	10,77	8,33	1853	26,1	9,66	8,11	1662	21,4	7,67	7,67	1320	13,9	5,98	5,98	1029	8,8
	7,5	1980	9,35	6,95	1607	20,2	8,37	6,72	1439	16,5	6,59	6,30	1133	10,6	5,07	5,07	872	6,5
	5	1345	7,50	5,31	1290	13,5	6,68	5,07	1150	11,0	5,20	4,66	895	6,9	3,95	3,95	679	4,1
	3	930	5,91	4,07	1017	8,8	5,28	3,86	908	7,1	4,07	3,48	701	4,4	3,05	3,02	525	2,6
	1	620	4,46	2,97	767	5,3	3,99	2,80	686	4,3	3,07	2,48	528	2,6	2,27	2,22	391	1,5
DFCL-ECM 34	10	3290	14,30	10,95	2460	34,0	12,85	10,65	2210	27,9	10,19	10,19	1752	18,1	7,92	7,92	1362	11,4
	7,5	2525	12,39	9,13	2132	26,2	11,10	8,81	1909	21,4	8,73	8,22	1502	13,7	6,71	6,71	1155	8,5
	5	1720	9,92	6,97	1707	17,5	8,87	6,66	1526	14,2	6,90	6,08	1186	9,0	5,23	5,23	900	5,4
	3	1170	7,73	5,27	1329	11,1	6,91	4,99	1188	9,0	5,34	4,48	918	5,6	4,00	3,95	687	3,3
	1	740	5,58	3,68	960	6,2	5,00	3,46	861	5,0	3,86	3,05	664	3,1	2,85	2,71	491	1,8
DFCL-ECM 44	10	3475	16,76	12,42	2883	28,2	15,04	12,01	2587	23,0	11,84	11,22	2036	14,8	9,11	9,11	1567	9,1
	7,5	2690	14,50	10,39	2494	21,6	12,98	9,97	2232	17,6	10,13	9,19	1743	11,2	7,73	7,73	1329	6,8
	5	1860	11,56	7,96	1989	14,3	10,33	7,56	1776	11,6	8,00	6,84	1376	7,3	6,02	6,02	1035	4,3
	3	1250	8,82	5,92	1516	8,8	7,89	5,58	1357	7,1	6,09	4,96	1047	4,4	4,52	4,45	778	2,6
	1	730	5,84	3,80	1005	4,2	5,26	3,57	905	3,4	4,06	3,12	699	2,1	2,99	2,75	514	1,2
DFCL-ECM 54	10	5095	23,58	18,16	4057	32,2	21,12	17,53	3633	26,2	16,67	16,67	2867	16,9	12,88	12,88	2215	10,5
	7,5	4355	21,63	16,25	3720	27,5	19,34	15,62	3327	22,4	15,18	14,49	2612	14,3	11,66	11,66	2006	8,8
	5	3550	19,24	14,05	3310	22,2	17,18	13,42	2955	18,1	13,41	12,32	2306	11,4	10,21	10,21	1757	6,9
	3	2580	15,83	11,25	2722	15,6	14,12	10,69	2429	12,7	10,96	9,67	1884	7,9	8,24	8,22	1417	4,7
	1	1480	10,80	7,25	1858	7,8	9,65	6,82	1659	6,3	7,43	6,03	1279	3,9	5,51	5,37	947	2,3

Cooling emission of 4 row DFCL-ECM coil

Entering air temperature: 26 °C – R. H.: 50% – AVAILABLE PRESSURE: 0 Pa

MODEL	Vdc	Qv m ³ /h	WT: 7/12 °C				WT: 8/13 °C				WT: 10/15 °C				WT: 12/17 °C			
			Pc kW	Ps kW	Qw l/h	Dp(c) kPa	Pc kW	Ps kW	Qw l/h	Dp(c) kPa	Pc kW	Ps kW	Qw l/h	Dp(c) kPa	Pc kW	Ps kW	Qw l/h	Dp(c) kPa
DFCL-ECM 14	10	1750	6,49	5,59	1117	10,8	5,79	5,43	996	8,8	4,55	4,55	783	5,6	3,81	3,81	655	4,0
	7,5	1520	6,01	5,05	1034	9,4	5,35	4,89	920	7,6	4,17	4,17	718	4,8	3,35	3,35	576	3,2
	5	1190	5,23	4,23	899	7,3	4,63	4,06	796	5,8	3,58	3,58	616	3,6	2,72	2,72	468	2,2
	3	870	4,32	3,37	743	5,1	3,81	3,21	656	4,1	2,92	2,89	502	2,5	2,19	2,17	377	1,5
	1	460	2,80	2,04	482	2,4	2,47	1,92	425	1,9	1,87	1,71	321	1,1	1,37	1,35	236	0,6
DFCL-ECM 24	10	2580	9,63	8,09	1656	21,3	8,61	7,88	1481	17,3	6,79	6,79	1168	11,2	5,26	5,26	905	7,0
	7,5	1980	8,32	6,71	1432	16,4	7,42	6,49	1277	13,2	5,80	5,80	997	8,4	4,44	4,44	763	5,1
	5	1345	6,65	5,07	1144	10,9	5,90	4,85	1015	8,7	4,54	4,54	782	5,4	3,43	3,43	589	3,2
	3	930	5,25	3,86	902	7,1	4,64	3,66	798	5,6	3,54	3,31	609	3,4	2,63	2,60	453	2,0
	1	620	3,96	2,81	682	4,2	3,50	2,64	603	3,4	2,65	2,34	456	2,0	1,95	1,92	335	1,2
DFCL-ECM 34	10	3290	12,78	10,62	2199	27,8	11,42	10,31	1965	22,7	9,00	9,00	1548	14,5	6,96	6,96	1197	9,0
	7,5	2525	11,06	8,80	1902	21,3	9,86	8,50	1697	17,2	7,68	7,68	1321	10,9	5,87	5,87	1010	6,6
	5	1720	8,82	6,66	1518	14,1	7,82	6,35	1345	11,4	6,03	5,81	1037	7,0	4,54	4,54	781	4,2
	3	1170	6,86	5,00	1180	9,0	6,08	4,73	1045	7,2	4,63	4,25	797	4,4	3,44	3,40	591	2,5
	1	740	4,97	3,47	855	5,0	4,40	3,25	756	4,0	3,33	2,87	573	2,4	2,44	2,40	419	1,3
DFCL-ECM 44	10	3475	14,94	11,98	2570	22,9	13,34	11,57	2294	18,5	10,41	10,41	1790	11,7	7,97	7,97	1371	7,2
	7,5	2690	12,91	9,97	2220	17,5	11,47	9,55	1973	14,1	8,88	8,88	1527	8,8	6,72	6,72	1157	5,3
	5	1860	10,26	7,57	1765	11,6	9,09	7,19	1564	9,2	6,97	6,51	1199	5,7	5,20	5,20	895	3,3
	3	1250	7,84	5,59	1348	7,1	6,93	5,26	1192	5,6	5,27	4,69	906	3,4	3,88	3,83	668	1,9
	1	730	5,22	3,58	899	3,4	4,63	3,35	796	2,7	3,50	2,93	602	1,6	2,54	2,50	437	0,9
DFCL-ECM 54	10	5095	21,04	17,50	3620	26,2	18,77	16,89	3228	21,2	14,70	14,70	2529	13,5	11,29	11,29	1942	8,3
	7,5	4355	19,27	15,61	3314	22,3	17,14	15,00	2948	18,0	13,36	13,36	2298	11,3	10,18	10,18	1752	6,9
	5	3550	17,11	13,43	2943	18,0	15,20	12,84	2614	14,4	11,74	11,74	2019	9,0	8,88	8,88	1528	5,4
	3	2580	14,05	10,70	2417	12,6	12,45	10,16	2142	10,1	9,54	9,21	1641	6,2	7,12	7,12	1225	3,6
	1	1480	9,58	6,84	1648	6,3	8,48	6,42	1458	5,0	6,42	5,68	1105	3,0	4,71	4,66	810	1,7

Note: the power absorption (Watt) at page 50 must be subtracted from the total and sensible cooling emission.

Cooling emission of 4 row DFCL-ECM coil

Entering air temperature: 25 °C – R. H.: 50% – AVAILABLE PRESSURE: 0 Pa

MODEL	Vdc	Qv m³/h	WT: 7/12 °C				WT: 8/13 °C				WT: 10/15 °C				WT: 12/17 °C			
			Pc kW	Ps kW	Qw l/h	Dp(c) kPa	Pc kW	Ps kW	Qw l/h	Dp(c) kPa	Pc kW	Ps kW	Qw l/h	Dp(c) kPa	Pc kW	Ps kW	Qw l/h	Dp(c) kPa
DFCL-ECM 14	10	1750	5,78	5,41	994	8,7	5,14	5,14	884	7,0	4,01	4,01	690	4,4	3,52	3,52	606	3,5
	7,5	1520	5,33	4,87	917	7,6	4,73	4,73	813	6,0	3,67	3,67	631	3,8	3,21	3,21	553	3,0
	5	1190	4,61	4,05	794	5,8	4,08	3,90	702	4,6	3,14	3,14	539	2,8	2,72	2,72	468	2,2
	3	870	3,80	3,21	654	4,1	3,34	3,06	575	3,2	2,54	2,52	437	1,9	2,19	2,17	376	1,5
	1	460	2,46	1,92	423	1,9	2,15	1,81	371	1,5	1,61	1,58	276	0,8	1,27	1,26	219	0,6
DFCL-ECM 24	10	2580	8,58	7,84	1475	17,3	7,65	7,65	1315	14,0	6,00	6,00	1032	8,9	5,23	5,23	900	7,0
	7,5	1980	7,39	6,46	1271	13,2	6,56	6,25	1128	10,6	5,09	5,09	876	6,6	4,40	4,40	756	5,1
	5	1345	5,87	4,85	1010	8,7	5,19	4,64	892	6,9	3,96	3,96	682	4,2	3,36	3,36	579	3,1
	3	930	4,62	3,66	794	5,6	4,06	3,47	698	4,4	3,07	3,03	528	2,6	2,38	2,35	409	1,7
	1	620	3,48	2,64	599	3,4	3,05	2,48	525	2,6	2,28	2,21	393	1,5	1,66	1,64	286	0,9
DFCL-ECM 34	10	3290	11,39	10,28	1959	22,6	10,15	10,15	1746	18,2	7,95	7,95	1367	11,6	6,94	6,94	1194	9,1
	7,5	2525	9,81	8,47	1688	17,2	8,70	8,16	1497	13,8	6,74	6,74	1159	8,6	5,83	5,83	1003	6,6
	5	1720	7,79	6,35	1340	11,3	6,87	6,06	1181	9,0	5,25	5,25	902	5,5	4,30	4,30	740	3,8
	3	1170	6,05	4,73	1041	7,2	5,32	4,48	915	5,6	4,01	3,96	689	3,4	2,98	2,95	513	2,0
	1	740	4,38	3,26	753	4,0	3,84	3,06	660	3,1	2,86	2,70	492	1,8	2,08	2,05	358	1,0
DFCL-ECM 44	10	3475	13,29	11,54	2285	18,5	11,79	11,13	2027	14,8	9,14	9,14	1572	9,3	7,92	7,92	1362	7,2
	7,5	2690	11,42	9,53	1964	14,0	10,10	9,14	1737	11,2	7,76	7,76	1334	6,9	6,64	6,64	1143	5,2
	5	1860	9,05	7,19	1557	9,2	7,97	6,83	1371	7,3	6,04	6,04	1040	4,4	4,71	4,71	810	2,8
	3	1250	6,90	5,27	1187	5,6	6,06	4,97	1042	4,4	4,54	4,43	781	2,6	3,32	3,29	572	1,5
	1	730	4,60	3,36	792	2,7	4,04	3,14	695	2,1	3,00	2,74	516	1,2	2,16	2,13	372	0,7
DFCL-ECM 54	10	5095	18,69	16,84	3215	21,2	16,63	16,27	2860	17,1	12,93	12,93	2224	10,7	11,44	11,44	1968	8,6
	7,5	4355	17,10	14,97	2940	18,0	15,13	14,39	2603	14,4	11,71	11,71	2014	8,9	10,31	10,31	1774	7,1
	5	3550	15,13	12,82	2603	14,4	13,37	12,26	2300	11,5	10,25	10,25	1764	7,0	8,95	8,95	1540	5,5
	3	2580	12,40	10,16	2133	10,0	10,91	9,65	1876	7,9	8,27	8,25	1423	4,8	6,87	6,88	1182	3,4
	1	1480	8,44	6,43	1451	5,0	7,40	6,04	1273	3,9	5,53	5,35	951	2,3	4,04	4,00	695	1,3

Note: the power absorption (Watt) at page 50 must be subtracted from the total and sensible cooling emission.

LEGEND

- WT = Water temperature
- Pc = Cooling total emission
- Ps = Cooling sensible emission
- Qw = Water flow
- Dp(c) = Water pressure drop
- Speed = Fan speed
- MAX = High speed
- MED = Medium speed
- MIN = Low speed
- Qv = Air flow

Heating emission of 3 row **DFCL-ECM** coil

Entering air temperature: 20 °C – AVAILABLE PRESSURE: 0 Pa

MODEL	Vdc	WT: 70/60 °C						WT: 60/50 °C			WT: 55/45 °C			WT: 50/40 °C			WT: 50/45 °C			WT: 45/40 °C			
		Qv	Ph	Qw	Dp(c)	Ph	Qw	Dp(c)	Ph	Qw	Dp(c)	Ph	Qw	Dp(c)	Ph	Qw	Dp(c)	Ph	Qw	Dp(c)	Ph	Qw	Dp(c)
		m³/h	kW	l/h	kPa	kW	l/h	kPa	kW	l/h	kPa	kW	l/h	kPa	kW	l/h	kPa	kW	l/h	kPa	kW	l/h	kPa
DFCL-ECM 13	10	1800	15,53	1336	17,4	11,81	1016	11,0	9,96	857	8,3	8,10	696	5,8	9,47	1629	26,4	7,63	1313	18,3			
	7,5	1580	14,25	1225	14,9	10,86	934	9,4	9,16	787	7,1	7,45	641	5,0	8,68	1493	22,6	7,01	1206	15,7			
	5	1280	12,35	1062	11,5	9,43	811	7,3	7,96	685	5,5	6,49	558	3,9	7,52	1294	17,4	6,08	1046	12,1			
	3	950	10,01	861	7,8	7,66	658	5,0	6,48	557	3,8	5,30	456	2,7	6,09	1047	11,9	4,93	849	8,3			
	1	505	6,92	595	4,0	5,33	458	2,6	4,52	389	2,0	3,72	320	1,4	4,21	723	6,1	3,42	588	4,3			
DFCL-ECM 23	10	2625	22,12	1902	31,8	16,92	1455	20,3	14,31	1230	15,3	11,68	1005	10,8	13,49	2320	48,3	10,92	1878	33,6			
	7,5	2030	18,69	1607	23,4	14,31	1231	15,0	12,12	1043	11,4	9,93	854	8,1	11,38	1958	35,6	9,23	1587	24,8			
	5	1375	14,26	1226	14,4	10,96	943	9,3	9,30	800	7,0	7,65	658	5,0	8,68	1492	21,7	7,05	1213	15,2			
	3	970	11,05	950	9,0	8,52	733	5,9	7,25	623	4,5	5,97	513	3,2	6,71	1155	13,7	5,46	940	9,6			
	1	640	8,02	690	5,1	6,21	534	3,3	5,30	455	2,5	4,38	377	1,8	4,87	837	7,6	3,97	683	5,4			
DFCL-ECM 33	10	3390	28,09	2416	34,9	21,49	1848	22,3	18,20	1565	16,8	14,88	1280	11,9	17,14	2948	53,0	13,88	2387	36,9			
	7,5	2565	23,42	2014	25,1	17,96	1545	16,1	15,23	1310	12,2	12,47	1073	8,7	14,27	2454	38,1	11,57	1991	26,6			
	5	1750	17,97	1546	15,6	13,83	1189	10,0	11,76	1011	7,6	9,66	831	5,5	10,94	1882	23,6	8,89	1529	16,5			
	3	1190	13,56	1166	9,3	10,47	900	6,1	8,91	766	4,6	7,35	632	3,3	8,25	1419	14,1	6,71	1154	9,9			
	1	760	9,59	825	5,0	7,43	639	3,3	6,35	546	2,5	5,26	452	1,8	5,82	1001	7,5	4,75	817	5,3			
DFCL-ECM 43	10	3535	34,28	2948	26,3	26,26	2259	16,9	22,25	1913	12,8	18,24	1568	9,1	20,88	3591	39,9	16,91	2908	27,8			
	7,5	2730	28,67	2465	19,1	22,04	1895	12,3	18,69	1607	9,3	15,35	1320	6,6	17,46	3002	28,9	14,15	2435	20,2			
	5	1890	21,92	1885	11,7	16,91	1454	7,6	14,38	1237	5,8	11,84	1018	4,2	13,33	2293	17,7	10,84	1864	12,4			
	3	1275	16,19	1393	6,8	12,53	1077	4,4	10,69	919	3,4	8,84	760	2,4	9,82	1689	10,2	8,01	1378	7,2			
	1	745	10,43	897	3,0	8,12	698	2,0	6,96	598	1,5	5,78	497	1,1	6,32	1087	4,6	5,17	890	3,2			
DFCL-ECM 53	10	5160	48,77	4194	43,4	37,35	3212	27,8	31,62	2719	21,0	25,88	2226	14,9	29,72	5111	65,7	24,04	4136	45,9			
	7,5	4400	43,82	3769	35,7	33,61	2891	22,9	28,50	2451	17,3	23,35	2008	12,4	26,68	4589	54,1	21,62	3719	37,8			
	5	3580	38,00	3268	27,6	29,21	2512	17,8	24,79	2132	13,5	20,35	1750	9,6	23,12	3977	41,7	18,77	3228	29,2			
	3	2605	30,18	2595	18,2	23,25	2000	11,8	19,79	1702	9,0	16,28	1400	6,4	18,34	3154	27,5	14,92	2566	19,3			
	1	1495	19,61	1687	8,3	15,20	1307	5,4	12,98	1116	4,2	10,74	924	3,0	11,89	2045	12,5	9,71	1671	8,8			

Heating emission of 4 row **DFCL-ECM** coil

Entering air temperature: 20 °C – AVAILABLE PRESSURE: 0 Pa

MODEL	Vdc	WT: 70/60 °C						WT: 60/50 °C			WT: 55/45 °C			WT: 50/40 °C			WT: 50/45 °C			WT: 45/40 °C			
		Qv	Ph	Qw	Dp(c)	Ph	Qw	Dp(c)	Ph	Qw	Dp(c)	Ph	Qw	Dp(c)	Ph	Qw	Dp(c)	Ph	Qw	Dp(c)	Ph	Qw	Dp(c)
		m³/h	kW	l/h	kPa	kW	l/h	kPa	kW	l/h	kPa	kW	l/h	kPa	kW	l/h	kPa	kW	l/h	kPa	kW	l/h	kPa
DFCL-ECM 14	10	1750	19,48	1675	15,4	14,91	1282	9,9	12,61	1085	7,4	10,30	886	5,3	11,85	2039	23,3	9,59	1650	16,2			
	7,5	1520	17,58	1512	12,8	13,49	1160	8,2	11,42	982	6,2	9,34	803	4,4	10,70	1840	19,3	8,67	1491	13,5			
	5	1190	14,64	1259	9,2	11,25	968	5,9	9,55	822	4,5	7,84	674	3,2	8,89	1529	13,8	7,22	1242	9,7			
	3	870	11,45	985	5,9	8,83	760	3,8	7,51	646	2,9	6,19	533	2,1	6,95	1195	8,8	5,65	972	6,2			
	1	460	6,72	578	2,2	5,23	449	1,5	4,47	385	1,1	3,71	319	0,8	4,06	699	3,3	3,33	572	2,4			
DFCL-ECM 24	10	2580	28,15	2421	28,9	21,62	1860	18,6	18,34	1577	14,1	15,06	1295	10,1	17,12	2944	43,8	13,90	2390	30,6			
	7,5	1980	23,26	2000	20,4	17,91	1540	13,3	15,24	1310	10,1	12,53	1078	7,2	14,13	2431	30,9	11,48	1975	21,7			
	5	1345	17,30	1488	12,0	13,38	1151	7,8	11,42	982	6,0	9,43	811	4,3	10,50	1806	18,0	8,56	1473	12,7			
	3	930	12,83	1104	7,0	9,97	858	4,6	8,53	733	3,5	7,08	609	2,6	7,78	1338	10,4	6,36	1094	7,4			
	1	620	9,10	783	3,7	7,10	611	2,5	6,10	524	1,9	5,08	437	1,4	5,50	946	5,6	4,51	776	4,0			
DFCL-ECM 34	10	3290	33,12	2848	30,4	25,44	2187	19,6	21,60	1857	14,8	17,73	1525	10,6	20,16	3468	46,1	16,36	2813	32,2			
	7,5	2525	27,49	2364	21,7	21,18	1821	14,1	18,01	1549	10,7	14,82	1274	7,7	16,72	2875	32,8	13,59	2337	23,1			
	5	1720	20,69	1779	12,9	15,98	1375	8,4	13,63	1172	6,4	11,25	968	4,7	12,56	2161	19,5	10,23	1760	13,8			
	3	1170	15,28	1314	7,5	11,86	1020	4,9	10,14	872	3,8	8,41	723	2,7	9,27	1595	11,3	7,57	1303	8,0			
	1	740	10,47	900	3,8	8,16	702	2,5	7,00	602	1,9	5,83	501	1,4	6,34	1090	5,6	5,19	893	4,0			
DFCL-ECM 44	10	3475	39,94	3435	26,5	30,79	2648	17,2	26,18	2252	13,1	21,59	1856	9,4	24,27	4175	39,9	19,76	3398	28,1			
	7,5	2690	32,99	2837	18,7	25,49	2192	12,2	21,73	1869	9,3	17,95	1544	6,7	20,03	3446	28,2	16,33	2809	19,9			
	5	1860	24,69	2123	11,1	19,17	1648	7,3	16,39	1409	5,6	13,57	1167	4,1	14,98	2576	16,6	12,24	2105	11,8			
	3	1250	17,77	1528	6,1	13,85	1191	4,0	11,87	1021	3,1	9,88	850	2,3	10,76	1850	9,1	8,81	1516	6,5			
	1	730	11,12	956	2,6	8,72	750	1,7	7,51	646	1,4	6,29	541	1,0	6,72	1155	3,9	5,53	951	2,8			
DFCL-ECM 54	10	5095	-	-	-	43,80	3767	21,9	37,19	3198	16,6	30,55	2627	11,9	34,63	5957	51,3	28,13	4838	35,9			
	7,5	4355	-	-	-	39,16	3368	17,9	33,29	2863	13,6	27,40	2356	9,8	30,91	5317	41,7	25,12	4320	29,2			
	5	3550	-	-	-	33,69	2897	13,6	28,70	2469	10,4	23,66	2035	7,5	26,51	4559	31,6	21,58	3712	22,2			
	3	2580	-	-	-	26,36	2267	8,7	22,51	1935	6,7	18,62	1601	4,8	20,64	3550	20,0	16,85	2898	14,2			
	1	1480	-	-	-	16,73	1438	3,8	14,34	1233	3,0	11,94	1027	2,2	12,97	2232	8,6	10,64	1829	6,2			

Heating emission of 1 row additional DFCL-ECM coil

Entering air temperature: 20 °C – AVAILABLE PRESSURE: 0 Pa

MODEL	Vdc	WT: 80/70 °C			WT: 75/65 °C			WT: 70/60 °C			WT: 65/55 °C			WT: 60/50 °C			WT: 55/45 °C			
		Qv m³/h	Ph kW	Qw l/h	Dp(c) kPa	Ph kW	Qw l/h	Dp(c) kPa	Ph kW	Qw l/h	Dp(c) kPa	Ph kW	Qw l/h	Dp(c) kPa	Ph kW	Qw l/h	Dp(c) kPa	Ph kW	Qw l/h	Dp(c) kPa
DFCL-ECM 13+1	10	1750	7,82	673	39,4	7,06	607	33,2	6,29	541	27,4	5,52	475	22,1	4,75	409	17,1	3,99	343	12,7
	7,5	1520	7,26	625	34,4	6,56	564	29,0	5,84	502	24,0	5,13	441	19,3	4,42	380	15,0	3,71	319	11,1
	5	1190	6,36	547	27,1	5,75	494	22,9	5,13	441	19,0	4,50	387	15,3	3,88	333	11,9	3,25	280	8,8
	3	870	5,32	457	19,6	4,80	413	16,5	4,28	368	13,7	3,76	324	11,1	3,25	279	8,6	2,73	235	6,4
	1	460	3,53	303	9,3	3,19	274	7,9	2,85	245	6,6	2,51	216	5,3	2,17	186	4,2	1,83	157	3,1
DFCL-ECM 23+1	10	2580	10,74	924	66,7	9,71	835	56,3	8,66	744	46,6	7,61	654	37,5	6,56	564	29,3	5,51	474	21,8
	7,5	1980	9,41	810	52,4	8,51	731	44,4	7,59	652	36,7	6,67	573	29,7	5,76	495	23,1	4,84	416	17,2
	5	1345	7,65	658	36,2	6,91	594	30,6	6,17	530	25,4	5,43	467	20,5	4,69	403	16,0	3,95	339	12,0
	3	930	6,12	527	24,2	5,53	476	20,5	4,94	425	17,0	4,35	374	13,8	3,77	324	10,8	3,17	273	8,1
	1	620	4,72	406	15,1	4,27	367	12,8	3,81	328	10,7	3,36	289	8,6	2,91	251	6,8	2,46	212	5,1
DFCL-ECM 33+1	10	3290	13,47	1159	84,0	12,14	1044	70,3	10,82	931	58,2	9,50	817	49,3	8,16	702	41,2	6,84	588	35,5
	7,5	2525	11,78	1013	66,0	10,63	914	58,2	9,47	814	50,0	8,31	715	43,5	7,16	616	36,0	6,00	516	31,6
	5	1720	9,60	826	52,8	8,66	745	47,6	7,72	664	41,9	6,78	583	35,9	5,85	503	30,0	4,91	422	26,4
	3	1170	7,61	655	40,0	6,87	591	37,2	6,13	527	33,5	5,40	464	28,5	4,65	400	23,6	3,92	337	20,9
	1	740	5,67	487	30,8	5,12	440	27,5	4,58	394	24,6	4,03	347	21,0	3,48	299	17,9	2,93	252	15,9
DFCL-ECM 43+1	10	3475	16,22	1395	95,9	14,64	1259	85,8	13,09	1125	71,2	11,52	991	59,4	9,94	855	50,2	8,38	721	44,8
	7,5	2690	14,17	1218	77,8	12,82	1102	74,8	11,44	984	63,3	10,07	866	52,4	8,70	749	43,0	7,34	631	38,8
	5	1860	11,50	989	63,5	10,41	895	60,1	9,29	799	50,0	8,20	705	42,2	7,09	610	36,0	5,98	514	31,9
	3	1250	8,95	769	47,6	8,10	697	45,1	7,24	623	39,9	6,39	549	32,9	5,53	476	28,0	4,67	402	24,6
	1	730	6,28	540	33,9	5,69	489	32,0	5,09	438	28,4	4,50	387	23,8	3,90	335	20,0	3,30	284	18,0
DFCL-ECM 53+1	10	5095	22,35	1922	136,0	20,17	1734	118,5	18,00	1548	100,0	15,85	1363	81,5	13,69	1177	66,0	11,53	992	62,5
	7,5	4355	20,56	1768	118,0	18,57	1597	107,7	16,60	1428	91,2	14,62	1258	76,3	12,63	1086	60,0	10,63	914	57,5
	5	3550	18,46	1588	100,3	16,67	1434	94,8	14,89	1281	83,9	13,12	1128	68,4	11,34	975	57,5	9,55	822	52,0
	3	2580	15,44	1328	78,0	13,95	1200	78,6	12,47	1073	70,6	11,00	946	57,0	9,51	818	49,0	8,03	690	44,0
	1	1480	10,81	930	55,4	9,78	841	56,6	8,74	752	51,0	7,72	664	40,5	6,69	575	35,0	5,65	486	31,0

Heating emission of 2 row additional DFCL-ECM coil

Entering air temperature: 20 °C – AVAILABLE PRESSURE: 0 Pa

MODEL	Vdc	WT: 65/55 °C			WT: 60/50 °C			WT: 55/45 °C			WT: 50/40 °C			WT: 45/40 °C			WT: 45/35 °C			
		Qv m³/h	Ph kW	Qw l/h	Dp(c) kPa	Ph kW	Qw l/h	Dp(c) kPa	Ph kW	Qw l/h	Dp(c) kPa	Ph kW	Qw l/h	Dp(c) kPa	Ph kW	Qw l/h	Dp(c) kPa	Ph kW	Qw l/h	Dp(c) kPa
DFCL-ECM 13+2	10	1650	12,26	1054	19,6	10,59	911	15,3	8,91	766	11,4	7,23	622	8	6,84	1177	25,4	5,54	476	5
	7,5	1405	11,07	952	16,3	9,57	823	12,8	8,05	693	9,5	6,54	563	6,7	6,18	1063	21,1	5,03	432	4,2
	5	1055	9,16	788	11,6	7,94	682	9,1	6,69	576	6,8	5,45	469	4,8	5,12	880	15	4,21	362	3,1
	3	740	7,16	616	7,4	6,21	534	5,8	5,25	452	4,4	4,29	369	3,1	3,99	686	9,6	3,33	286	2
	1	400	4,49	387	3,2	3,91	336	2,5	3,33	286	1,9	2,74	235	1,4	2,51	431	4,1	2,14	184	0,9
DFCL-ECM 23+2	10	2485	17,83	1534	45,5	15,43	1327	35,7	13,04	1122	26,8	10,63	914	18,9	9,97	1715	59,2	8,22	707	12,1
	7,5	1895	15,03	1292	33,4	13,03	1121	26,3	11,02	948	19,8	9,01	775	14	8,4	1445	43,4	6,98	600	9
	5	1285	11,61	999	20,9	10,09	867	16,5	8,55	736	12,5	7,01	603	8,9	6,49	1116	27,2	5,46	470	5,8
	3	865	8,75	752	12,5	7,62	655	9,9	6,48	557	7,6	5,33	458	5,4	4,89	841	16,3	4,17	359	3,6
	1	570	6,37	548	7	5,56	478	5,6	4,74	408	4,3	3,92	337	3,1	3,56	612	9,1	3,08	265	2,1
DFCL-ECM 33+2	10	3120	22,02	1894	58,4	19	1634	48,9	16,02	1378	35,9	12,99	1117	26,4	12,3	2115	72,1	9,97	857	16,6
	7,5	2441	18,89	1624	45,3	16,34	1405	40,1	13,77	1184	30,3	11,2	963	23,9	10,55	1815	57,5	8,62	741	13,6
	5	1645	14,57	1253	33,6	12,62	1085	30,9	10,67	918	23,1	8,71	749	17,6	8,13	1399	44,5	6,74	580	10,2
	3	1125	11,13	957	24,8	9,66	831	22,5	8,19	705	17,4	6,71	577	13,1	6,21	1068	35,6	5,22	449	7,2
	1	690	7,69	662	17,8	6,69	576	16,3	5,70	490	13,6	4,69	404	10,6	4,29	738	26,9	3,68	316	5,1
DFCL-ECM 43+2	10	3355	26,11	2245	71,1	22,66	1949	56,7	19,19	1650	42,2	15,69	1349	32,6	14,6	2511	81,4	12,19	1049	22,4
	7,5	2612	22,18	1907	55,8	19,27	1657	45,9	16,35	1406	36,6	13,4	1152	28,6	12,41	2134	66,6	10,44	897	19,1
	5	1800	17,2	1479	41,6	14,96	1286	35,3	12,71	1093	27,4	10,45	899	23,8	9,6	1651	51,8	8,18	704	15,8
	3	1200	12,75	1096	30,8	11,11	956	26,9	9,47	814	20,3	7,82	673	17,6	7,12	1224	39,6	6,15	529	12,5
	1	700	8,35	718	22,2	7,3	628	19,4	6,25	537	14,3	5,18	446	12,5	4,66	801	27,2	4,11	353	8,7
DFCL-ECM 53+2	10	4970	35,93	3090	100,4	31,12	2676	78,8	26,29	2261	54,2	21,43	1843	43,5	20,08	3454	104,4	16,68	1434	32,0
	7,5	4260	32,65	2808	80,8	28,29	2433	70,3	23,93	2058	49,2	19,54	1681	39,6	18,24	3138	94,5	14,80	1273	28,7
	5	3485	28,66	2465	68,5	24,89	2140	60,2	21,05	1811	43,7	17,22	1481	34,6	16,02	2756	83,4	11,81	1016	23,4
	3	2525	23,10	1987	51,6	20,05	1724	47,7	17,02	1464	35,9	13,97	1201	28,5	12,91	2220	67,9	9,08	781	18,0
	1	1450	15,42	1326	37,6	13,43	1155	33,6	11,44	984	23,8	9,44	811	20,2	8,60	1479	45,4	6,25	537	12,0

LEGEND

WT = Water temperature
Ph = Emission
Qw = Water flow

Dp(c) = Water pressure drop
Qv = Air flow
Speed = Fan speed

MAX = High speed
MED = Medium speed
MIN = Low speed

Air flow (m³/h)
depending on speed and requested available pressure with 4 row coil

Available pressure (Pa)														
MODEL	V	0	10	20	30	40	50	60	70	80	90	100	110	120
DFCL-ECM 14	10	1750	1720	1680	1640	1600	1555	1005	1455	1400	1340	1270	1200	1120
	9,5	1705	1675	1640	1595	1550	1500	1450	1390	1325	1260	1180	1100	1020
	9	1665	1630	1590	1545	1500	1440	1380	1320	1240	1160	1080	990	900
	8,5	1615	1575	1535	1485	1435	1370	1300	1220	1140	1045	950	860	770
	8	1560	1520	1475	1420	1360	1285	1200	1105	1010	910	815	720	625
	7,5	1520	1470	1410	1345	1275	1190	1100	1000	900	790	690	585	485
	7	1460	1400	1335	1260	1180	1090	985	880	760	650	540	430	-
	6,5	1405	1330	1260	1175	1080	980	860	740	620	500	-	-	-
	6	1330	1250	1165	1070	965	850	720	600	460	-	-	-	-
	5,5	1265	1180	1080	975	855	720	580	435	-	-	-	-	-
	5	1190	1090	980	860	720	560	400	-	-	-	-	-	-
	4,5	1020	1010	882	740	580	410	-	-	-	-	-	-	-
	4	1040	920	770	610	440	265	-	-	-	-	-	-	-
	3	870	700	505	300	-	-	-	-	-	-	-	-	-
2	650	445	160	-	-	-	-	-	-	-	-	-	-	
1	460	-	-	-	-	-	-	-	-	-	-	-	-	
DFCL-ECM 24	10	2580	2555	2525	2500	2470	2440	2410	2370	2330	2280	2240	2180	2120
	9,5	2460	2440	2410	2380	2350	2320	2280	2245	2205	2160	2115	2060	1995
	9	2360	2340	2310	2280	2255	2220	2185	2150	2105	2060	2010	1950	1880
	8,5	2225	2200	2165	2140	2100	2065	2030	1990	1940	1895	1840	1780	1705
	8	2100	2070	2040	2005	1975	1940	1900	1860	1820	1765	1710	1645	1575
	7,5	1980	1940	1900	1860	1820	1780	1740	1700	1645	1600	1540	1470	1385
	7	1830	1800	1760	1725	1685	1645	1605	1565	1520	1465	1400	1335	1225
	6,5	1740	1690	1645	1600	1555	1510	1460	1410	1355	1295	1210	1110	950
	6	1590	1545	1500	1460	1410	1365	1320	1265	1200	1135	1060	940	700
	5,5	1465	1420	1380	1330	1280	1225	1170	1105	1040	960	840	660	340
	5	1345	1300	1245	1195	1140	1085	1025	960	880	780	650	300	-
	4,5	1240	1180	1115	1050	990	925	855	780	695	585	420	-	-
	4	1080	1015	960	900	840	780	705	630	540	420	-	-	-
	3	930	840	760	685	620	555	480	405	320	-	-	-	-
2	760	660	560	460	380	-	-	-	-	-	-	-	-	
1	620	490	380	-	-	-	-	-	-	-	-	-	-	
DFCL-ECM 34	10	3290	3240	3190	3140	3100	3050	3000	2960	2910	2860	2820	2770	2720
	9,5	3120	3080	3045	3000	2960	2920	2880	2835	2790	2740	2690	2640	2600
	9	3000	2960	2920	2880	2840	2800	2760	2710	2660	2610	2560	2510	2460
	8,5	2840	2805	2770	2735	2695	2650	2605	2560	2520	2470	2415	2360	2300
	8	2720	2680	2640	2600	2565	2525	2480	2425	2370	2310	2250	2190	2130
	7,5	2525	2485	2455	2415	2375	2330	2280	2225	2175	2115	2055	1990	1930
	7	2380	2335	2295	2250	2005	2160	2100	2040	1980	1920	1860	1795	1735
	6,5	2200	2155	2110	2065	2015	1950	1890	1830	1760	1700	1640	1580	1520
	6	2040	1980	1920	1860	1800	1730	1665	1600	1540	1480	1430	1375	1320
	5,5	1840	1795	1750	1690	1630	1560	1495	1425	1360	1300	1240	1190	1140
	5	1720	1650	1585	1510	1420	1350	1280	1205	1155	1100	1055	1000	960
	4,5	1540	1490	1420	1340	1255	1180	1120	1060	1000	945	895	840	800
	4	1430	1340	1250	1155	1080	1010	945	885	835	785	740	700	655
	3	1170	1060	940	840	755	685	630	575	520	465	-	-	-
2	900	760	640	550	475	405	-	-	-	-	-	-	-	
1	740	550	440	355	-	-	-	-	-	-	-	-	-	

Air flow (m³/h)
depending on speed and requested available pressure *with 4 row coil*

Available pressure (Pa)														
MODEL	V	0	10	20	30	40	50	60	70	80	90	100	110	120
DFCL-ECM 44	10	3475	3425	3380	3335	3280	3240	3185	3140	3085	3035	2980	2930	2880
	9,5	3320	3280	3240	3200	3155	3105	3060	3010	2960	2905	2855	2800	2740
	9	3200	3160	3120	3080	3035	2980	2940	2885	2830	2730	2720	2660	2605
	8,5	3335	2990	2945	2900	2860	2805	2760	2700	2650	2600	2540	2480	2420
	8	2875	2830	2780	2740	2690	2640	2580	2530	2475	2420	2360	2295	2235
	7,5	2690	2640	2590	2540	2495	2440	2380	2330	2270	2205	2145	2080	2020
	7	2510	2460	2405	2360	2300	2240	2180	2120	2060	2000	1940	1880	1815
	6,5	2340	2280	2230	2180	2120	2060	2000	1935	1870	1800	1740	1670	1600
	6	2170	2115	2060	1995	1930	1860	1795	1720	1645	1580	1500	1435	1360
	5,5	2020	1960	1895	1825	1760	1680	1605	1535	1460	1385	1310	1240	1170
	5	1860	1790	1720	1640	1565	1495	1410	1330	1255	1180	1110	1040	975
	4,5	1700	1620	1540	1460	1375	1285	1210	1135	1060	990	920	855	795
	4	1500	1420	1320	1240	1155	1070	995	920	850	790	720	660	-
	3	1250	1120	1000	900	810	730	660	585	-	-	-	-	-
	2	940	800	680	580	485	-	-	-	-	-	-	-	-
1	730	570	460	-	-	-	-	-	-	-	-	-	-	
DFCL-ECM 54	10	5095	5060	5020	4985	4945	4900	4860	4810	4760	4700	4645	4580	4515
	9,5	4910	4880	4840	4805	4765	4725	4680	4640	4580	4525	4465	4400	4335
	9	4775	4740	4705	4665	4625	4580	4535	4480	4430	4375	4310	4240	4160
	8,5	4630	4595	4560	4520	4475	4430	4380	4335	4280	4220	4150	4080	4000
	8	4505	4465	4430	4395	4350	4300	4260	4200	4150	4080	4020	3940	3855
	7,5	4355	4320	4280	4240	4200	4160	4100	4050	3995	3930	3850	3765	3675
	7	4235	4200	4160	4120	4075	4025	3980	3920	3850	3775	3695	3600	3480
	6,5	4085	4040	4010	3970	3920	3860	3800	3740	3675	3590	3500	3380	3245
	6	3960	3920	3880	3825	3780	3720	3660	3580	3505	3420	3300	3170	3000
	5,5	3690	3660	3620	3580	3540	3490	3440	3375	3300	3205	3100	2945	2740
	5	3550	3520	3485	3445	3400	3355	3300	3230	3145	3040	2900	2685	2415
	4,5	3240	3210	3170	3125	3080	3025	2960	2885	2795	2690	2540	2345	2080
	4	3055	3020	2980	2940	2885	2825	2760	2690	2595	2480	2300	2040	1660
	3	2580	2525	2480	2420	2360	2300	2220	2130	2020	1860	1605	1120	-
	2	2020	1940	1860	1780	1710	1640	1555	1460	1340	1260	-	-	-
1	1480	1400	1300	1180	1065	-	-	-	-	-	-	-	-	

Power absorption (Watt)
depending on air flow and available pressure

Available pressure (Pa)														
MODEL	V	0	10	20	30	40	50	60	70	80	90	100	110	120
DFCL-ECM 14	10	154	158	161	164	168	170	172	172	172	170	167	163	157
	9,5	142	146	150	154	157	158	159	158	157	154	149	144	137
	9	133	137	140	143	144	146	145	144	140	135	130	123	117
	8,5	122	126	130	133	134	133	131	127	122	116	110	105	100
	8	113	118	120	121	120	118	114	109	103	98	93	88	83
	7,5	104	108	110	110	107	103	98	93	88	84	79	74	70
	7	96	98	98	96	92	87	82	78	74	70	65	60	-
	6,5	88	86	84	82	78	74	69	65	60	56	-	-	-
	6	75	74	71	68	64	60	56	52	46	-	-	-	-
	5,5	65	63	60	57	54	50	45	40	-	-	-	-	-
	5	55	53	50	47	43	38	34	-	-	-	-	-	-
	4,5	47	45	42	38	34	30	-	-	-	-	-	-	-
	4	40	37	34	30	26	24	-	-	-	-	-	-	-
	3	26	23	20	18	-	-	-	-	-	-	-	-	-
	2	16	14	12	-	-	-	-	-	-	-	-	-	-
1	10	-	-	-	-	-	-	-	-	-	-	-	-	
DFCL-ECM 24	10	372	374	378	380	384	385	385	384	382	378	374	367	358
	9,5	324	328	332	336	338	339	340	340	338	336	332	326	318
	9	290	293	297	300	305	306	307	306	304	302	298	293	285
	8,5	254	254	255	255	256	256	256	256	256	254	253	250	244
	8	206	210	212	214	216	220	222	224	228	228	226	224	220
	7,5	183	183	183	183	184	186	188	189	190	190	190	187	180
	7	142	144	146	149	152	156	159	162	163	164	163	161	152
	6,5	125	127	128	130	132	134	136	136	137	136	133	128	116
	6	102	104	105	107	109	112	114	116	116	116	115	110	84
	5,5	86	87	88	89	91	92	94	95	96	96	92	82	61
	5	66	66	68	70	72	74	77	80	80	80	74	53	-
	4,5	48	52	56	60	61	63	64	66	66	63	55	-	-
	4	42	43	44	46	49	52	54	56	55	51	-	-	-
	3	25	27	29	31	33	35	37	38	38	-	-	-	-
	2	16	17	19	21	22	-	-	-	-	-	-	-	-
1	12	13	14	-	-	-	-	-	-	-	-	-	-	
DFCL-ECM 34	10	542	542	542	542	542	540	538	536	534	533	532	530	530
	9,5	473	476	480	482	482	482	482	482	480	479	478	478	478
	9	424	426	428	429	430	430	429	428	426	425	424	452	423
	8,5	375	377	380	383	383	383	383	382	382	382	382	382	382
	8	337	338	340	340	341	342	342	342	339	337	338	338	340
	7,5	264	266	272	276	280	282	284	286	288	290	292	294	296
	7	220	224	228	232	233	238	240	242	243	246	246	250	252
	6,5	178	182	186	190	194	197	200	202	204	206	208	211	213
	6	144	147	150	153	156	158	160	164	166	170	172	174	176
	5,5	116	118	120	123	126	129	132	135	137	140	142	144	145
	5	85	88	92	94	98	100	103	106	108	111	113	115	117
	4,5	72	74	76	78	82	84	86	89	92	94	96	97	98
	4	54	57	60	63	65	67	69	71	73	75	76	78	80
	3	30	34	37	39	41	43	44	46	47	48	-	-	-
	2	20	21	22	23	24	26	-	-	-	-	-	-	-
1	13	14	15	16	-	-	-	-	-	-	-	-	-	

**Power absorption (Watt)
depending on air flow and available pressure**

		Available pressure (Pa)												
MODEL	Vdc	0	10	20	30	40	50	60	70	80	90	100	110	120
DFCL-ECM 44	10	506	516	524	533	536	538	538	536	535	533	530	528	527
	9,5	536	447	456	462	466	472	474	476	477	476	476	476	475
	9	386	395	404	410	418	422	424	426	427	427	427	427	426
	8,5	330	336	342	347	350	355	358	362	364	366	368	370	372
	8	273	279	286	291	296	302	307	311	314	317	320	322	325
	7,5	226	232	238	244	248	254	257	260	264	267	270	272	275
	7	184	186	193	197	203	206	210	214	218	222	226	228	232
	6,5	155	158	162	164	168	172	176	180	185	189	192	196	200
	6	120	124	127	132	136	140	144	148	153	156	160	164	166
	5,5	100	104	106	111	114	119	122	126	129	132	136	138	140
	5	78	82	85	89	93	96	98	102	104	107	110	112	115
	4,5	70	70	71	73	76	80	82	84	87	89	92	94	96
	4	48	51	55	58	60	62	64	66	68	70	72	74	-
	3	30	34	36	38	40	41	42	42	-	-	-	-	-
	2	18	20	22	22	24	-	-	-	-	-	-	-	-
1	12	14	14	-	-	-	-	-	-	-	-	-	-	
DFCL-ECM 54	10	1031	1035	1039	1041	1043	1043	1043	1041	1038	1033	1027	1019	1008
	9,5	907	911	916	919	922	924	924	924	922	919	915	908	900
	9	803	809	814	819	823	826	829	830	829	828	824	819	810
	8,5	749	754	759	764	768	770	772	773	772	769	765	759	749
	8	701	707	712	715	719	721	722	722	721	717	713	705	694
	7,5	644	649	654	658	661	662	663	663	661	656	649	639	626
	7	594	599	604	607	609	611	610	609	604	598	589	576	557
	6,5	528	535	538	542	545	547	547	546	542	535	525	508	487
	6	476	482	488	493	496	497	497	495	490	482	468	449	423
	5,5	400	405	412	418	422	425	427	428	426	420	410	391	362
	5	349	356	363	370	376	380	384	385	383	377	363	336	298
	4,5	273	281	289	297	304	309	313	315	313	307	294	273	243
	4	235	244	253	260	268	273	277	277	275	268	252	224	189
	3	144	152	158	165	170	174	177	179	178	173	159	126	-
	2	79	85	90	96	100	103	107	109	111	111	-	-	-
1	41	43	45	50	55	-	-	-	-	-	-	-	-	

Correction factors for Total cooling emission

MODEL	Vdc	Available pressure (Pa)												
		0	10	20	30	40	50	60	70	80	90	100	110	120
DFCL-ECM 14	10	1,00	0,99	0,98	0,97	0,95	0,94	0,92	0,91	0,89	0,86	0,84	0,81	0,77
	9,5	1,00	0,99	0,98	0,97	0,95	0,93	0,92	0,90	0,87	0,85	0,81	0,78	0,74
	9	1,00	0,99	0,98	0,96	0,95	0,93	0,90	0,88	0,85	0,82	0,78	0,74	0,69
	8,5	1,00	0,99	0,97	0,96	0,94	0,92	0,89	0,86	0,82	0,78	0,73	0,69	0,64
	8	1,00	0,99	0,97	0,95	0,93	0,90	0,87	0,82	0,78	0,73	0,68	0,63	0,57
	7,5	1,00	0,98	0,96	0,94	0,91	0,88	0,84	0,79	0,74	0,68	0,62	0,55	0,49
	7	1,00	0,98	0,95	0,92	0,89	0,85	0,80	0,75	0,68	0,61	0,54	0,46	-
	6,5	1,00	0,97	0,94	0,91	0,87	0,82	0,75	0,68	0,61	0,53	-	-	-
	6	1,00	0,97	0,93	0,89	0,84	0,77	0,70	0,62	0,52	-	-	-	-
	5,5	1,00	0,96	0,92	0,87	0,80	0,72	0,62	0,51	-	-	-	-	-
	5	1,00	0,95	0,90	0,83	0,75	0,63	0,51	-	-	-	-	-	-
	4,5	1,00	0,95	0,88	0,79	0,68	0,54	-	-	-	-	-	-	-
	4	1,00	0,94	0,85	0,73	0,59	0,42	-	-	-	-	-	-	-
	3	1,00	0,89	0,73	0,51	-	-	-	-	-	-	-	-	-
2	1,00	0,81	0,41	-	-	-	-	-	-	-	-	-	-	
1	1,00	-	-	-	-	-	-	-	-	-	-	-	-	
DFCL-ECM 24	10	1,00	0,99	0,99	0,98	0,98	0,97	0,96	0,96	0,95	0,94	0,93	0,91	0,90
	9,5	1,00	0,99	0,99	0,98	0,98	0,97	0,96	0,95	0,94	0,93	0,92	0,91	0,89
	9	1,00	0,99	0,99	0,98	0,98	0,97	0,96	0,95	0,94	0,93	0,92	0,90	0,88
	8,5	1,00	0,99	0,98	0,98	0,97	0,96	0,95	0,94	0,93	0,92	0,90	0,89	0,86
	8	1,00	0,99	0,98	0,98	0,97	0,96	0,95	0,94	0,93	0,91	0,90	0,88	0,85
	7,5	1,00	0,99	0,98	0,97	0,96	0,95	0,93	0,92	0,91	0,89	0,87	0,85	0,82
	7	1,00	0,99	0,98	0,97	0,96	0,95	0,93	0,92	0,91	0,89	0,86	0,84	0,80
	6,5	1,00	0,98	0,97	0,96	0,94	0,93	0,91	0,89	0,87	0,85	0,82	0,77	0,70
	6	1,00	0,98	0,97	0,96	0,94	0,92	0,91	0,88	0,86	0,83	0,79	0,74	0,61
	5,5	1,00	0,98	0,97	0,95	0,93	0,91	0,89	0,86	0,83	0,79	0,72	0,62	0,40
	5	1,00	0,98	0,96	0,94	0,92	0,89	0,86	0,83	0,79	0,73	0,65	0,39	-
	4,5	1,00	0,97	0,95	0,92	0,89	0,85	0,81	0,77	0,71	0,63	0,51	-	-
	4	1,00	0,97	0,94	0,91	0,87	0,83	0,78	0,73	0,66	0,56	-	-	-
	3	1,00	0,95	0,90	0,84	0,79	0,74	0,67	0,60	0,51	-	-	-	-
2	1,00	0,93	0,84	0,75	0,66	-	-	-	-	-	-	-	-	
1	1,00	0,88	0,75	-	-	-	-	-	-	-	-	-	-	
DFCL-ECM 34	10	1,00	0,99	0,98	0,97	0,97	0,96	0,95	0,95	0,94	0,93	0,92	0,91	0,90
	9,5	1,00	0,99	0,99	0,98	0,97	0,97	0,96	0,95	0,94	0,93	0,92	0,91	0,91
	9	1,00	0,99	0,98	0,98	0,97	0,96	0,96	0,95	0,94	0,93	0,92	0,91	0,90
	8,5	1,00	0,99	0,99	0,98	0,97	0,96	0,96	0,95	0,94	0,93	0,92	0,91	0,89
	8	1,00	0,99	0,98	0,98	0,97	0,96	0,95	0,94	0,93	0,92	0,90	0,89	0,88
	7,5	1,00	0,99	0,98	0,98	0,97	0,96	0,95	0,94	0,92	0,91	0,89	0,88	0,86
	7	1,00	0,99	0,98	0,97	0,96	0,95	0,94	0,92	0,91	0,89	0,87	0,86	0,84
	6,5	1,00	0,99	0,98	0,97	0,95	0,94	0,92	0,91	0,89	0,87	0,85	0,83	0,81
	6	1,00	0,98	0,97	0,95	0,94	0,92	0,90	0,88	0,86	0,84	0,82	0,80	0,78
	5,5	1,00	0,99	0,97	0,96	0,94	0,92	0,89	0,87	0,85	0,82	0,80	0,78	0,76
	5	1,00	0,98	0,96	0,93	0,90	0,88	0,85	0,82	0,80	0,77	0,75	0,73	0,71
	4,5	1,00	0,98	0,96	0,93	0,90	0,86	0,84	0,81	0,78	0,75	0,73	0,70	0,68
	4	1,00	0,97	0,93	0,89	0,86	0,82	0,79	0,76	0,73	0,70	0,67	0,65	0,62
	3	1,00	0,95	0,89	0,83	0,78	0,73	0,69	0,65	0,61	0,57	-	-	-
2	1,00	0,91	0,83	0,75	0,68	0,62	-	-	-	-	-	-	-	
1	1,00	0,85	0,74	0,64	-	-	-	-	-	-	-	-	-	

Correction factors for Total cooling emission

		Available pressure (Pa)												
MODEL	Vdc	0	10	20	30	40	50	60	70	80	90	100	110	120
DFCL-ECM 44	10	1,00	0,99	0,98	0,98	0,97	0,96	0,95	0,95	0,94	0,93	0,92	0,91	0,90
	9,5	1,00	0,99	0,99	0,98	0,97	0,96	0,96	0,95	0,94	0,93	0,92	0,91	0,90
	9	1,00	0,99	0,99	0,98	0,97	0,96	0,96	0,95	0,94	0,92	0,92	0,91	0,90
	8,5	1,00	0,99	0,98	0,98	0,97	0,96	0,95	0,94	0,93	0,92	0,91	0,90	0,88
	8	1,00	0,99	0,98	0,97	0,97	0,96	0,94	0,93	0,92	0,91	0,90	0,89	0,87
	7,5	1,00	0,99	0,98	0,97	0,96	0,95	0,94	0,93	0,91	0,90	0,88	0,87	0,85
	7	1,00	0,99	0,98	0,97	0,95	0,94	0,93	0,91	0,90	0,88	0,87	0,85	0,83
	6,5	1,00	0,99	0,97	0,96	0,95	0,93	0,92	0,90	0,89	0,87	0,85	0,83	0,81
	6	1,00	0,99	0,97	0,96	0,94	0,92	0,90	0,88	0,86	0,84	0,81	0,79	0,76
	5,5	1,00	0,98	0,97	0,95	0,93	0,91	0,88	0,86	0,83	0,81	0,78	0,75	0,73
	5	1,00	0,98	0,96	0,94	0,91	0,89	0,86	0,83	0,80	0,77	0,74	0,71	0,68
	4,5	1,00	0,97	0,95	0,92	0,89	0,86	0,83	0,80	0,76	0,73	0,70	0,66	0,63
	4	1,00	0,97	0,93	0,90	0,87	0,83	0,79	0,75	0,72	0,68	0,64	0,61	-
	3	1,00	0,94	0,89	0,83	0,78	0,73	0,68	0,63	-	-	-	-	-
	2	1,00	0,92	0,84	0,76	0,67	-	-	-	-	-	-	-	-
1	1,00	0,87	0,77	-	-	-	-	-	-	-	-	-	-	
DFCL-ECM 54	10	1,00	0,99	0,99	0,99	0,98	0,98	0,97	0,97	0,96	0,96	0,95	0,95	0,94
	9,5	1,00	0,99	0,99	0,99	0,98	0,98	0,97	0,97	0,96	0,96	0,95	0,94	0,94
	9	1,00	0,99	0,99	0,99	0,98	0,98	0,97	0,97	0,96	0,95	0,95	0,94	0,93
	8,5	1,00	0,99	0,99	0,99	0,98	0,98	0,97	0,97	0,96	0,95	0,94	0,94	0,93
	8	1,00	0,99	0,99	0,99	0,98	0,98	0,97	0,96	0,96	0,95	0,94	0,93	0,92
	7,5	1,00	0,99	0,99	0,98	0,98	0,98	0,97	0,96	0,96	0,95	0,94	0,93	0,91
	7	1,00	0,99	0,99	0,98	0,98	0,97	0,97	0,96	0,95	0,94	0,93	0,92	0,90
	6,5	1,00	0,99	0,99	0,98	0,98	0,97	0,96	0,95	0,95	0,93	0,92	0,90	0,88
	6	1,00	0,99	0,99	0,98	0,98	0,97	0,96	0,95	0,94	0,93	0,91	0,89	0,86
	5,5	1,00	0,99	0,99	0,98	0,98	0,97	0,96	0,95	0,94	0,93	0,91	0,88	0,85
	5	1,00	0,99	0,99	0,98	0,98	0,97	0,96	0,95	0,94	0,92	0,90	0,86	0,80
	4,5	1,00	0,99	0,99	0,98	0,97	0,96	0,95	0,94	0,92	0,91	0,88	0,84	0,78
	4	1,00	0,99	0,99	0,98	0,97	0,96	0,95	0,93	0,92	0,89	0,86	0,80	0,70
	3	1,00	0,99	0,98	0,97	0,95	0,94	0,92	0,90	0,88	0,83	0,76	0,60	-
	2	1,00	0,98	0,96	0,94	0,91	0,89	0,87	0,83	0,79	0,76	-	-	-
1	1,00	0,97	0,93	0,88	0,83	-	-	-	-	-	-	-	-	

Correction factors for Sensible cooling emission and Heating emission

MODEL	Available pressure (Pa)													
	V	0	10	20	30	40	50	60	70	80	90	100	110	120
DFCL-ECM 14	10	1,00	0,99	0,97	0,96	0,94	0,92	0,90	0,88	0,85	0,83	0,79	0,76	0,72
	9,5	1,00	0,99	0,97	0,95	0,93	0,91	0,89	0,86	0,84	0,80	0,77	0,73	0,69
	9	1,00	0,98	0,97	0,95	0,93	0,90	0,88	0,85	0,81	0,77	0,73	0,68	0,63
	8,5	1,00	0,98	0,96	0,94	0,92	0,89	0,86	0,82	0,78	0,73	0,68	0,63	0,58
	8	1,00	0,98	0,96	0,94	0,91	0,87	0,83	0,78	0,73	0,67	0,62	0,56	0,50
	7,5	1,00	0,98	0,95	0,92	0,88	0,84	0,79	0,74	0,68	0,62	0,55	0,49	0,42
	7	1,00	0,97	0,94	0,90	0,86	0,81	0,75	0,69	0,62	0,55	0,47	0,40	-
	6,5	1,00	0,96	0,93	0,88	0,83	0,77	0,70	0,62	0,54	0,46	-	-	-
	6	1,00	0,96	0,91	0,86	0,79	0,72	0,64	0,55	0,45	-	-	-	-
	5,5	1,00	0,95	0,89	0,83	0,75	0,66	0,56	0,45	-	-	-	-	-
	5	1,00	0,94	0,87	0,79	0,69	0,57	0,44	-	-	-	-	-	-
	4,5	1,00	0,93	0,84	0,74	0,61	0,47	-	-	-	-	-	-	-
	4	1,00	0,92	0,81	0,68	0,52	0,36	-	-	-	-	-	-	-
	3	1,00	0,86	0,67	0,45	-	-	-	-	-	-	-	-	-
2	1,00	0,76	0,35	-	-	-	-	-	-	-	-	-	-	
1	1,00	-	-	-	-	-	-	-	-	-	-	-	-	
DFCL-ECM 24	10	1,00	0,99	0,98	0,98	0,97	0,96	0,95	0,94	0,93	0,92	0,90	0,89	0,87
	9,5	1,00	0,99	0,98	0,98	0,97	0,96	0,95	0,94	0,93	0,91	0,90	0,88	0,86
	9	1,00	0,99	0,98	0,98	0,97	0,96	0,95	0,94	0,92	0,91	0,89	0,87	0,85
	8,5	1,00	0,99	0,98	0,97	0,96	0,95	0,94	0,92	0,91	0,89	0,87	0,85	0,83
	8	1,00	0,99	0,98	0,97	0,96	0,95	0,93	0,92	0,90	0,88	0,86	0,84	0,81
	7,5	1,00	0,98	0,97	0,96	0,94	0,93	0,91	0,90	0,88	0,86	0,84	0,81	0,77
	7	1,00	0,99	0,97	0,96	0,94	0,93	0,91	0,90	0,88	0,85	0,83	0,80	0,75
	6,5	1,00	0,98	0,96	0,94	0,92	0,90	0,88	0,86	0,84	0,81	0,77	0,72	0,64
	6	1,00	0,98	0,96	0,94	0,92	0,90	0,88	0,85	0,82	0,78	0,75	0,68	0,54
	5,5	1,00	0,98	0,96	0,93	0,91	0,88	0,85	0,82	0,78	0,74	0,66	0,55	0,33
	5	1,00	0,98	0,95	0,92	0,89	0,86	0,82	0,78	0,73	0,67	0,58	0,32	-
	4,5	1,00	0,97	0,93	0,89	0,85	0,81	0,76	0,71	0,65	0,57	0,44	-	-
	4	1,00	0,96	0,92	0,88	0,84	0,79	0,73	0,67	0,60	0,49	-	-	-
	3	1,00	0,93	0,87	0,80	0,75	0,68	0,61	0,54	0,45	-	-	-	-
2	1,00	0,91	0,80	0,69	0,60	-	-	-	-	-	-	-	-	
1	1,00	0,85	0,70	-	-	-	-	-	-	-	-	-	-	
DFCL-ECM 34	10	1,00	0,99	0,98	0,97	0,96	0,95	0,94	0,93	0,92	0,91	0,90	0,89	0,87
	9,5	1,00	0,99	0,98	0,97	0,96	0,95	0,94	0,93	0,92	0,91	0,90	0,89	0,88
	9	1,00	0,99	0,98	0,97	0,96	0,95	0,94	0,93	0,92	0,91	0,89	0,88	0,87
	8,5	1,00	0,99	0,98	0,97	0,96	0,95	0,94	0,93	0,92	0,91	0,89	0,88	0,86
	8	1,00	0,99	0,98	0,97	0,96	0,95	0,94	0,92	0,91	0,89	0,87	0,86	0,84
	7,5	1,00	0,99	0,98	0,97	0,96	0,94	0,93	0,91	0,90	0,88	0,86	0,84	0,83
	7	1,00	0,99	0,97	0,96	0,95	0,93	0,92	0,90	0,88	0,86	0,84	0,82	0,80
	6,5	1,00	0,98	0,97	0,96	0,94	0,92	0,90	0,88	0,85	0,83	0,81	0,79	0,77
	6	1,00	0,98	0,96	0,94	0,92	0,89	0,87	0,84	0,82	0,79	0,77	0,75	0,73
	5,5	1,00	0,98	0,96	0,94	0,92	0,89	0,86	0,83	0,80	0,78	0,75	0,73	0,70
	5	1,00	0,97	0,94	0,91	0,87	0,84	0,81	0,77	0,75	0,72	0,70	0,67	0,65
	4,5	1,00	0,98	0,94	0,91	0,86	0,83	0,80	0,76	0,73	0,70	0,67	0,64	0,62
	4	1,00	0,95	0,91	0,86	0,82	0,78	0,74	0,70	0,67	0,64	0,61	0,59	0,56
	3	1,00	0,93	0,86	0,79	0,73	0,67	0,63	0,59	0,55	0,50	-	-	-
2	1,00	0,89	0,78	0,70	0,62	0,55	-	-	-	-	-	-	-	
1	1,00	0,81	0,68	0,58	-	-	-	-	-	-	-	-	-	

Correction factors for Sensible cooling emission and Heating emission

		Available pressure (Pa)												
MODEL	V	0	10	20	30	40	50	60	70	80	90	100	110	120
DFCL-ECM 44	10	1,00	0,99	0,98	0,97	0,96	0,95	0,94	0,93	0,92	0,91	0,90	0,89	0,88
	9,5	1,00	0,99	0,98	0,97	0,96	0,95	0,94	0,93	0,92	0,91	0,90	0,89	0,87
	9	1,00	0,99	0,98	0,97	0,96	0,95	0,94	0,93	0,92	0,89	0,89	0,88	0,86
	8,5	1,00	0,99	0,98	0,97	0,96	0,95	0,94	0,92	0,91	0,90	0,88	0,87	0,85
	8	1,00	0,99	0,98	0,97	0,95	0,94	0,93	0,91	0,90	0,89	0,87	0,85	0,84
	7,5	1,00	0,99	0,97	0,96	0,95	0,93	0,92	0,90	0,89	0,87	0,85	0,83	0,81
	7	1,00	0,98	0,97	0,96	0,94	0,92	0,91	0,89	0,87	0,85	0,83	0,81	0,79
	6,5	1,00	0,98	0,97	0,95	0,93	0,91	0,89	0,87	0,85	0,83	0,81	0,78	0,76
	6	1,00	0,98	0,96	0,94	0,92	0,90	0,87	0,85	0,82	0,80	0,77	0,74	0,71
	5,5	1,00	0,98	0,96	0,93	0,91	0,88	0,85	0,82	0,79	0,76	0,73	0,70	0,67
	5	1,00	0,97	0,95	0,91	0,88	0,86	0,82	0,79	0,75	0,72	0,68	0,65	0,62
	4,5	1,00	0,97	0,93	0,90	0,86	0,82	0,78	0,75	0,71	0,67	0,64	0,60	0,57
	4	1,00	0,96	0,91	0,87	0,83	0,78	0,74	0,70	0,66	0,62	0,58	0,54	-
	3	1,00	0,93	0,85	0,79	0,73	0,67	0,62	0,57	-	-	-	-	-
	2	1,00	0,89	0,79	0,70	0,61	-	-	-	-	-	-	-	-
1	1,00	0,84	0,71	-	-	-	-	-	-	-	-	-	-	
DFCL-ECM 54	10	1,00	0,99	0,99	0,98	0,98	0,97	0,97	0,96	0,95	0,94	0,94	0,93	0,92
	9,5	1,00	0,99	0,99	0,98	0,98	0,97	0,97	0,96	0,95	0,94	0,94	0,93	0,92
	9	1,00	0,99	0,99	0,98	0,98	0,97	0,96	0,96	0,95	0,94	0,93	0,92	0,91
	8,5	1,00	0,99	0,99	0,98	0,98	0,97	0,96	0,95	0,95	0,94	0,93	0,91	0,90
	8	1,00	0,99	0,99	0,98	0,97	0,97	0,96	0,95	0,94	0,93	0,92	0,91	0,90
	7,5	1,00	0,99	0,99	0,98	0,97	0,97	0,96	0,95	0,94	0,93	0,92	0,90	0,89
	7	1,00	0,99	0,99	0,98	0,97	0,96	0,96	0,95	0,93	0,92	0,91	0,89	0,87
	6,5	1,00	0,99	0,99	0,98	0,97	0,96	0,95	0,94	0,93	0,91	0,90	0,87	0,85
	6	1,00	0,99	0,98	0,98	0,97	0,96	0,95	0,93	0,92	0,90	0,88	0,85	0,82
	5,5	1,00	0,99	0,99	0,98	0,97	0,96	0,95	0,94	0,92	0,91	0,88	0,85	0,81
	5	1,00	0,99	0,99	0,98	0,97	0,96	0,95	0,94	0,92	0,90	0,87	0,82	0,76
	4,5	1,00	0,99	0,98	0,97	0,96	0,95	0,94	0,92	0,90	0,88	0,84	0,79	0,72
	4	1,00	0,99	0,98	0,97	0,96	0,95	0,93	0,91	0,89	0,86	0,82	0,75	0,64
	3	1,00	0,98	0,97	0,96	0,94	0,92	0,90	0,87	0,84	0,79	0,71	0,54	-
	2	1,00	0,97	0,94	0,91	0,89	0,86	0,83	0,79	0,74	0,71	-	-	-
1	1,00	0,96	0,91	0,85	0,79	-	-	-	-	-	-	-	-	

2 pipe units

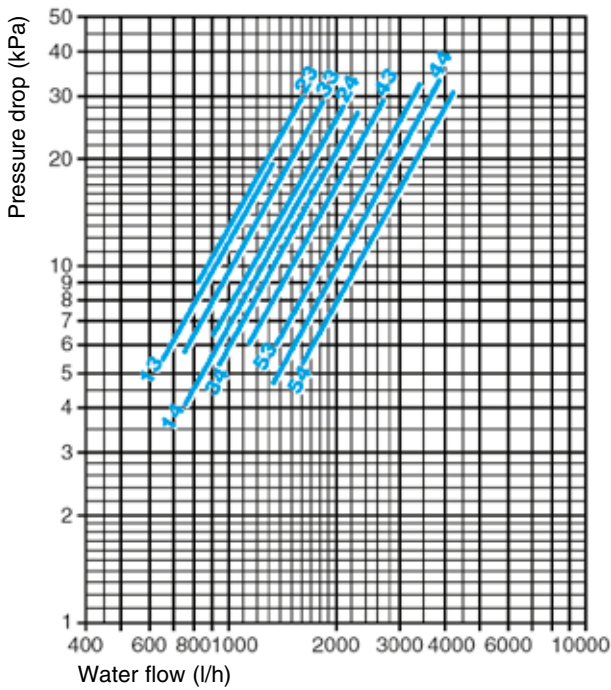

The water pressure drop figures refer to a mean water temperature of **10 °C**; for different temperatures, multiply the pressure drop figures by the correction factors **K**.

°C	20	30	40	50	60	70	80
K	0,94	0,90	0,86	0,82	0,78	0,74	0,70

4 pipe units
(heating coil pressure drop)

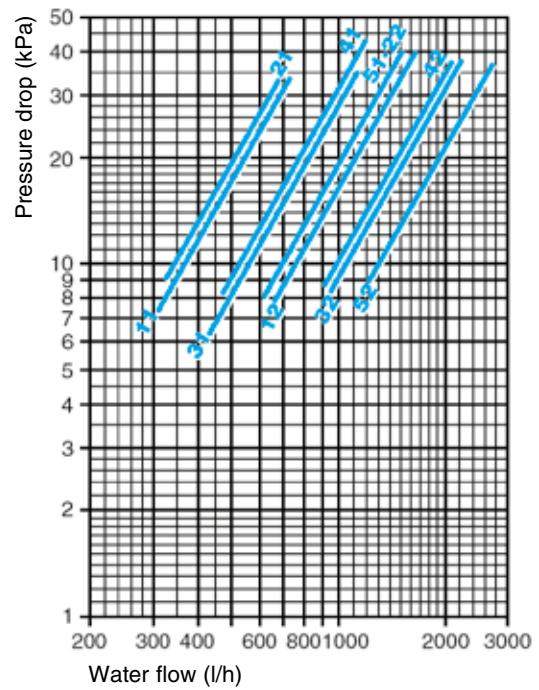

The water pressure drop figures refer to a mean water temperature of **60 °C**; for different temperatures, multiply the pressure drop figures by the correction factors **K**.

°C	40	50	70	80
K	1,12	1,06	0,94	0,88

Accessory air side pressure drop

Spigot plenum pressure drop

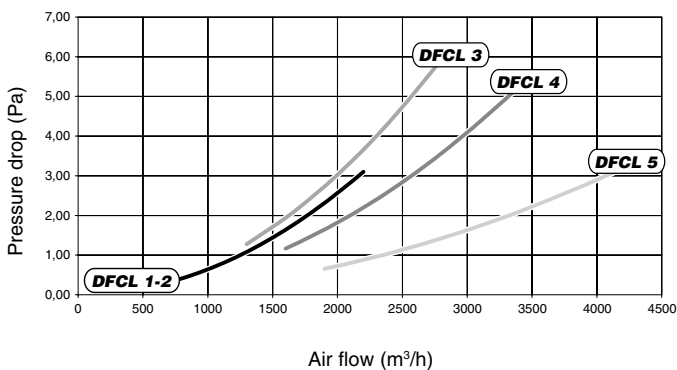

48 mm G4 filter pressure drop

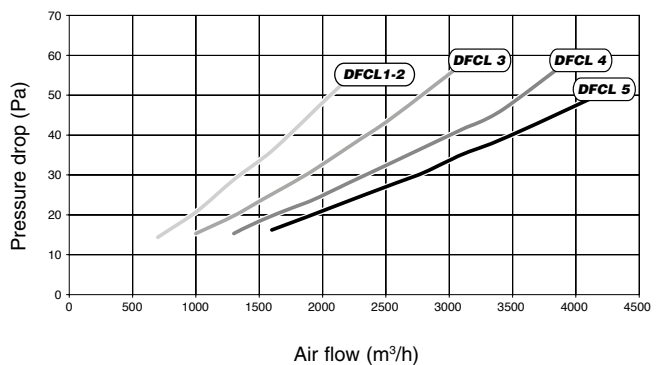

IDENTIFICATION	CODE
WM-AU	9066632E



Dimensions: 135x86x24 mm

The control must always be connected with UPO-AU power unit (to be ordered separately).

- ON-OFF switch.
- Manual, automatic or centralized Summer/Winter switch.
- Manual or automatic 3 speed progressive switch.
- Summer/Winter/Fan/Auto mode switch.
- Electronic room thermostat for fan control (ON-OFF).
- Electronic room thermostat for valve control (ON-OFF).
- Simultaneous thermostatic control of the valves and fan.
- It allows to control the low temperature cut-out thermostat (NTC).
- Energy saving switch.
- Presence of a LED signal when the thermostat is on.

Control power absorption: see the UPO-AU power unit

IDENTIFICATION	CODE
T-MB	9066331E



Dimensions: 110x72x25 mm

The control must always be connected with UPO-AU power unit (to be ordered separately).

Wall control with display that allows controlling one or more units in Master/Slave mode. The control is equipped with internal sensor to detect the room temperature, which can be defined as a priority compared to the return air sensor on the fan coil.

The T-MB control features the following functions:

- Switch the unit ON and OFF.
- Temperature set.
- Manual, centralized or automatic Summer/Winter switch.
- Set the fan speed (low, medium, high or autofan).
- Set the operation mode (fan only, cooling, heating, auto).
- Possibility of use of the low temperature cut-out thermostat NTC mounted on the UPO-AU power unit.
- Time setting.
- Weekly ON/OFF program.

Control power absorption: see the UPO-AU power unit

DESCRIPTION	IDENTIFICATION	CODE
Power unit for WM-AU and T-MB remote controls for all units, fitted on the unit.	UPOM1-AU	9034170
Power unit for WM-AU and T-MB remote controls for all units, not fitted on the unit.	UPO1-AU	9034169



Power unit to be installed on the fan coil (fan coil interface).

- It controls the fan and the valves of the fan coil.
- It is connected to the electric supply.
- It receives the information required from the control.
- Possibility of use of the low temperature cut-out thermostat NTC:
 - T1 function for the return air control.
 - T2 function which controls the summer/winter switch.
 - T3 function as low temperature cut-out thermostat.
- It allows to control up to 10 units (1 master and 9 slaves).
- Max. Network length: 100 meters.
- Max cable length between control and first connected power unit: 20 meters.

Control power absorption: 2,3 VA

NTC low temperature cut-out thermostat

To be fitted between the coil fins; when connecting the control, the NTC probe cable must be separated from the power supply wires.

To be used only with WM-TQR control and the UPO-AU power-unit.

It stops the fan when the water temperature is lower than 28 °C

and it starts the fan when is higher than 33 °C.

To use as:

- T1 function for the return air control.
- T2 function which controls the summer/winter switch.
- T3 function as low temperature cut-out thermostat.



IDENTIFICATION	CODE
NTC	3021090

T2 accessory

Type NTC sensor, to be placed on the water supply pipe upstream 3 way valves (not to be used with 2 way valves). The T2 sensor must be used as described below:

- Change-Over for the automatic switch of the operating mode. If water temperature is lower than 20 °C, cooling mode is set; on the other hand, if water temperature exceeds 30 °C, heating mode is set.

To be used with UPO-AU power-unit.

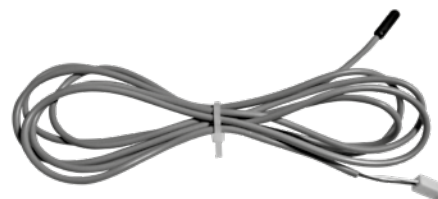

IDENTIFICATION	CODE
T2	9025310

All the **DFCL** units can be supplied with a wide range of controls, which allows managing one single unit or several units by using the Modbus RTU - RS 485. Units can be managed according to the Master/Slave logic (up to 20 units) or by supervisory components. The system consists in a **QCV-MB** board with **T-MB** included wall control and a series of controls, such as the **PSM-DI** multifunction control and the **NET** supervisory program.

To be used with valves with 3 points – 24 Volt actuator or with ON/OFF 230 V valves

QCV-MB control board

DESCRIPTION	IDENTIFICATION	CODE
MB version control board for DFCL sizes 1÷6 and DFCL-ECM sizes 1÷5, fitted on the unit (it can be used with 24V - 3 points valve or 230V ON-OFF valves).	QCV-MB-M 1-6	9034150
MB version control board for DFCL size 7 only, fitted on the unit (it can be used with 24V - 3 points valve or 230V ON-OFF valves).	QCV-MB-M 7	9034157
MB version control board for DFCL sizes 1÷6 and DFCL-ECM sizes 1÷5, not fitted on the unit (it can be used with 24V - 3 points valve or 230V ON-OFF valves).	QCV-MB-S 1-6	9034140
MB version control board for DFCL size 7 only, not fitted on the unit (it can be used with 24V - 3 points valve or 230V ON-OFF valves).	QCV-MB-S 7	9034147

The **QCV-MB** electronic board is set to carry out different functions and adjustment modes, in order to meet the installation requirements. These modes are selected by setting the configuration dip switches on the board.

- 2/4 pipe system.
- Electronic room thermostat or automatic fan speed modulation for fan control (On-OFF).
- Valve thermostatic control and continuous ventilation.
- Valve and simultaneous ventilation thermostatic control.
- Fan operation control depending on the coil temperature (cut-out T3 probe fitted), which can be activated only in heating mode or heating and cooling mode.
- Automatic switch of the operating mode by means of T2 water probe (optional) applied on the 2 pipe system.
- Seasonal switch by means of remote contact.
- ON/OFF of the fan coil by means of the remote contact (window or clock contact).
- Electric heater control.

By activating the cut-out T3 probe function, the fan is stopped in winter when the coil temperature is lower than 32 °C and started when the temperature reaches 36 °C. In summer mode, the fan stops when the temperature inside the coil exceeds 22 °C and starts when it drops below 18 °C.

The following connections are located on the power board:

- T-MB wall control.
- RS 485 serial connection to manage several fan coils in Master/Slave configuration or to create a supervisory network.

T-MB wall control (included with the QCV-MB control board)

Wall control with display that allows controlling one or more units in Master/Slave mode. The control is equipped with internal sensor to detect the room temperature, which can be defined as a priority compared to the return air sensor on the fan coil. The **T-MB** control features the following functions:

- Switch the appliance ON and OFF.
- Temperature set.
- Modify the set point (when used as a +/- 3° variation of the set point configured from NET supervisory program or PSM-DI).
- Set the fan speed (low, medium, high or autofan).
- Set the operation mode (fan only, cooling, heating; auto for 4 pipe systems with mode selection depending on the air temperature).
- Time setting.
- Weekly ON/OFF program.
- Display and change of the fan coil operation parameters.



Dimensions: 110x72x25 mm

A group of **DFCL** units with **QCV-MB** control board can be connected via a serial link and can consequently be managed at the same time by just one **T-MB** wall control. Using the special jumper present on the board, one unit must be configured as the master, and all the others as slaves.

With T-MB wall control

One control for each unit

(MAXIMUM LENGTH OF THE CONNECTION CABLE = 20 m)



One control for more units (20 units max.)

(MAXIMUM TOTAL LENGTH OF THE CONNECTION CABLE = 800 m)

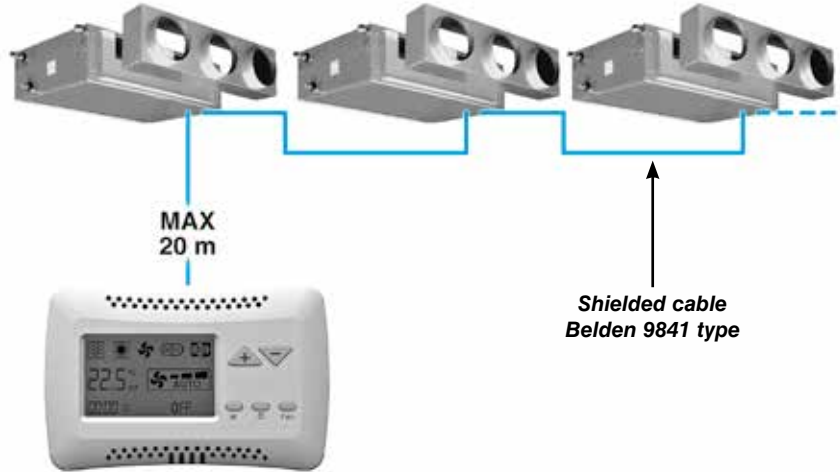

T2 accessory for units with QCV-MB control board

IDENTIFICATION	CODE
T2	9025310

The T2 sensor can be combined with MB boards to be placed on the water supply pipe upstream 3 way valves (not to be used with 2 way valve).

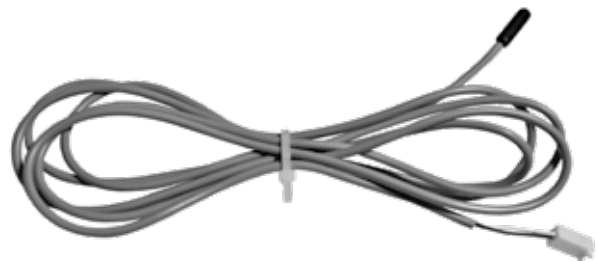

The T2 sensor must be used as described below:

- Change-Over for 2-pipe system for the automatic switch of the operating mode. If water temperature is lower than 20 °C, cooling mode is set; on the other hand, if water temperature exceeds 30 °C, heating mode is set.
- It can be used on units with electric heater and hot water supply. The T2 priority probe activates the electric heater or water valve, depending on the water temperature detected. If water temperature exceeds 34 °C, the water valve ON-OFF control is activated; on the other hand, if water temperature is lower than 30 °C, the electric heater is activated.

PSM-DI multifunction control panel

DESCRIPTION	IDENTIFICATION	CODE
Multifunction control (to be used with QCV-MB control board only)	PSM-DI	3021293

Another option available for the serial communication between the units is the possibility to connect up to 60 **DFCL** units in series and manage them with just one wall mounted **PSM-DI** controller. The wall mounted controller can be used to set the operating mode for each individual unit connected, display the operating conditions of each individual unit, and set the ON/OFF time sets for each day of the week (the program can be set for all the units and for a maximum of ten groups of units).

If more than 60 units need to be connected, two or more control panels must be used. Each unit must have a MB board. The **PSM-DI** control is used to manage a series of fan coils, up to a maximum of 60 units (the maximum length of the RS 485 connection cable must not exceed 800 m), from one single control point.

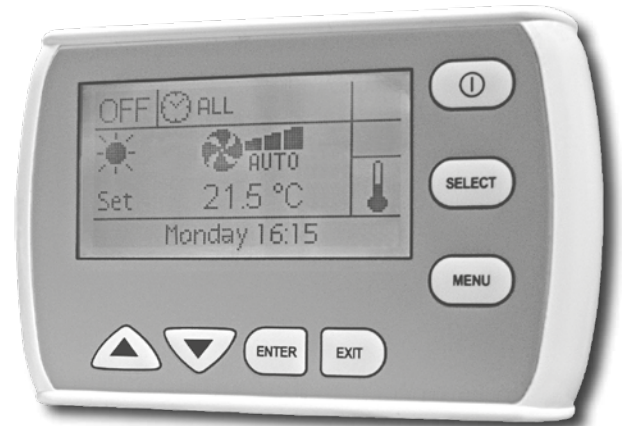

The **PSM-DI** control communicates via a serial line with all the units connected, with the possibility of controlling them all together or individually. In fact, the unique address of each individual fan coil means that all the units can be called at the same time, or the individual unit called, to perform the following functions:

- display the current operating mode, the fan speed, the set point;
- display the room temperature measured on the individual unit;
- turn all the units ON and OFF at the same time or alternatively each unit individually;
- change the operating mode (fan only, heating, cooling, automatic changeover);
- change the set point;
- modify the values and operation parameters of the fan speed.

Each function can then be sent to all the units connected, or alternatively to each individual unit.

Different set points or operating modes can be set for each individual unit.

The **PSM-DI** panel can also be used for the time management of the units over the week. Four ON times and four OFF times can be set on the units for each day of the week. A different temperature set that will be considered as Operation set for all connected appliances, can be set for each event. If the temperature set is not entered for the individual event, it must be set during programming for each individual unit or for the entire network.

The PSM-DI panel cannot be used together with the NET management program (see page 63).

Notes:

- set the Dip Switches of each fan coil as illustrated in the installation manual, based on the required solutions.
- it is possible to connect only one SIOS board per each PSM-DI control panel.
- about “Priority pump function”: when just one unit calls for, the relay RL1 on the SIOS board is automatically activated to connect a hot water pump.
- the RS 485 network’s overall length must not exceed 700/800 metres.

T-DI Touch screen multifunction control panel

DESCRIPTION	IDENTIFICATION	CODE
T-DI Touch screen multifunction control panel	T-DI	9066685



The T-DI multifunction control panel lets supervise and control more units with MB or SIOS boards; the panel is equipped with a 7 inches touch screen display and a serie of graphical pages that allows an easy reading of the data sent by the fan coils and the management of up to 60 units (max. 60 units: SIOS + MB).

With the multifunction control panel T-DI it is also possible to control the units from a distance with the specific Cloud APP for android and iOS. The Cloud APP is simple to use and lets have complete control of all the connected units.

Web gateway for Cloud

DESCRIPTION	IDENTIFICATION	CODE
Web gateway for Cloud	Web gateway	9066892



With the Web gateway for “Cloud” it is possible to control from a distance up to 60 units, equipped with MB or SIOS boards (max. 60 units: SIOS + MB), with the specific APP for android and iOS.

The “Cloud” APP is simple to use and lets have complete control of all the connected units.

NET program for managing a network of fan coils

DESCRIPTION	IDENTIFICATION	CODE
Hardware/software supervisory system (to be used with QCV-MB control board only)	NET	9079118

NET is a centralised control system for networks of MB fan coils, based on software that runs on LINUX™ operating system (the program is provided pre-installed on a PC) and it works in a “stand alone” way, as an ordinary computer, so that it can be connected to a monitor, to a mouse and to a keyboard. By connecting an Ethernet cable is instead possible to work at a distance and visualize the entire program setting-up through whatever browsers. The NET software offers a practical and economical solution for managing the units, with the simple click of the mouse.

The main characteristics are:

- simplicity of use;
- an extremely complete and functional weekly program;
- possibility to access the historical operating data for each individual unit connected;
- possibility of data saving on USB key;
- visualization of the saved configuration on a new ASUS PC.

The program can be used to:

- Create uniform groups (groups of units on individual floors, in offices or rooms).
- Save weekly programs configured for different types of operation (summer, winter, mid seasons, closing periods etc.); these can then be recalled and activated with a simple click of the mouse. Weekly on/off cycles can be set for individual units or groups of units.
- Set the operating conditions for each individual unit or groups of units (operating mode, fan speed, temperature setting).
- Set the set point limits for each individual unit or groups of units.
- Switch each individual unit or groups of units ON or OFF.

With the NET multifunction control panel it is also possible to control the units remotely with the specific Cloud App for Android and iOS.

The Cloud APP is simple to use and lets have complete control of all the connected units.



Graphical pages

The main program screen can display and interact with the entire network of units.

An individual unit, a group of units or the entire network can be called so as to make modifications to the operating mode and the set point.

The user can then check the operating status of each individual unit, read the room temperature, the coil temperature and the operating status of the condensate drain pump or any alarms.

The “**Monitoring**” Screen shows the units that are connected to the network and scanned by the program.

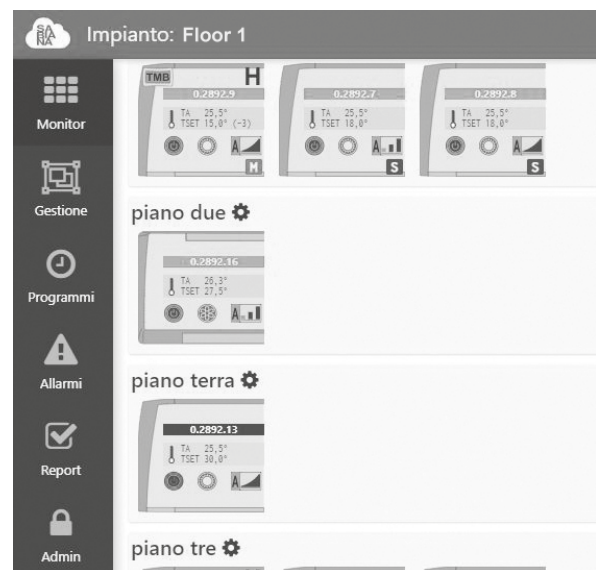

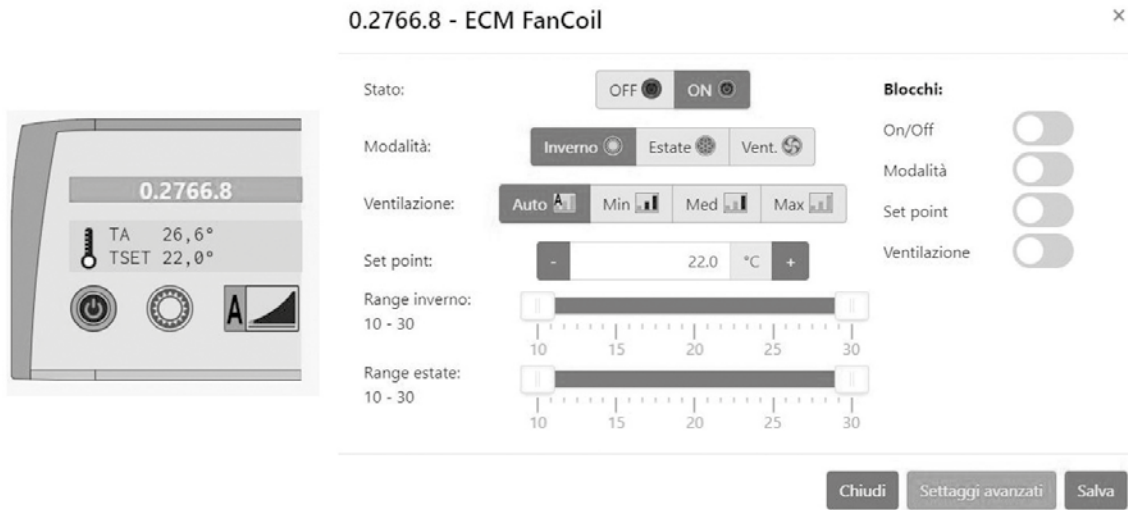

The icon of the terminal unit provides the following information:

- unit name (0.2766.8)
- set temperature (SETP)
- room temperature (AT)
- unit status:



- mode:



- fan speed:



The “**Programs**” Screen, can be used to set the unit operating parameters for each day of the week. Several weekly programs can be set. Time bands are available for each day of the week. The time and the type of operation to be performed by the unit can be set for each band. The time and the operating parameters can then be displayed before being sent to the unit and implemented.

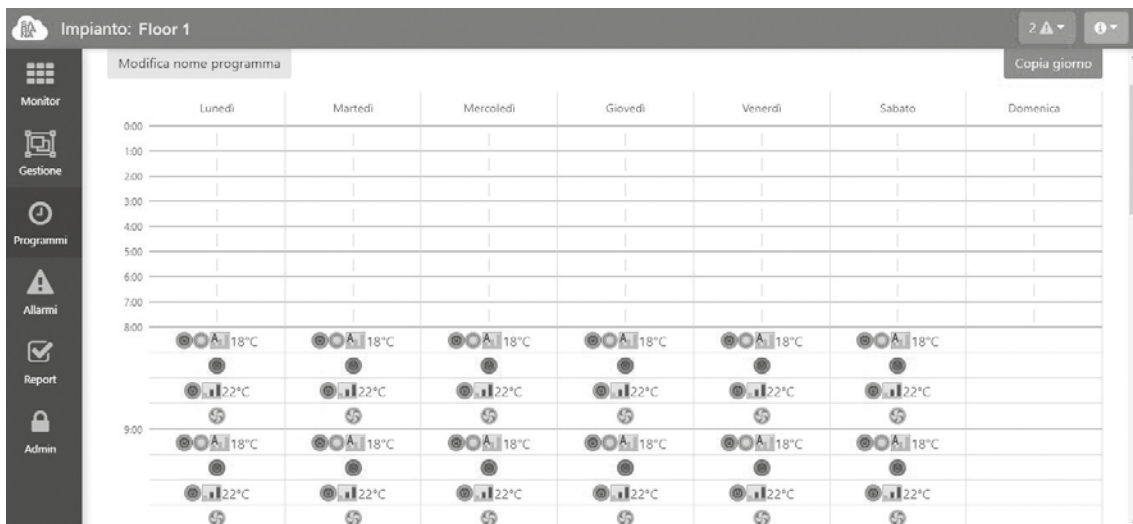

Every time that the reading of the set up Dip Switches results not easy (as for example by the false ceiling installations), it is always possible to display them directly through the NET program.

camera 54 - 0.2892.10 - ECM FanCoil

Stato unità
Configurazione
Parametri

Dip	OFF option	ON option
1: OFF	Impianto a 2 tubi	Impianto a 4 tubi
2: OFF	Termostatazione con valvole	Termostatazione con Fan
3: OFF	T3 disabilitata	T3 abilitata
4: OFF	T3 solo Inverno quando abilitata	T3 Inverno ed Estate quando abilitata
5: OFF	Ventilazione continua	Ventilazione contemporanea delle valvole
6: OFF	IAQ	Gestione Resistenze
7: OFF	T2 come Change-Over CH (resistenza II° gradino)	Gestione Resistenze con T2
8: OFF	RL7 (D0-D0) abbinato allo stato del controllore	--
9: OFF	CA = ON/OFF remoto	CA = Estate/Inverno remoto
10: OFF	Master	Slave

camera 54 - 0.2892.10 - ECM FanCoil

Stato unità
Configurazione
Parametri

T3 ventilatore ON riscaldamento	- 34.0 °C +	T3 ventilatore ON raffreddamento	- 22.0 °C +
Isteresi T3 per ventilatore	- 5.0 °C +	Tempo massimo OFF ventilatore per antistratificazione	- 10 min. +
Tempo ON antistratificazione	- 60 sec. +	Tempo post ventilazione	- 180 sec. +
ECM tensione velocità minima	- 1.0 V +	ECM tensione velocità media	- 5.0 V +
ECM tensione velocità massima	- 10.0 V +	Offset sonda T-MB	- 0.0 °C +

« 1 2 3 4 »

Chiudi Reset parametri Salva

In addition to the alarm set on the "**Alarms**" Screen, it is possible to send the ON-OFF alarm notification via E-mail and sms.

Impianto: Floor 1
2
1

- Monitor
- Gestione
- Programmi
- Allarmi**
- Report
- Admin

Storico allarmi
Impostazioni notifica allarmi

Tipo evento		eMail
Unità in allarme [qualsiasi]	All'attivazione invia	immediatamente
Unità in allarme condensa	All'attivazione invia	mai
Unità in allarme sonda	All'attivazione invia	mai
Unità persa	All'attivazione invia	mai
0.2892.6.1	All'attivazione invia	mai
0.2892.6.2	All'attivazione invia	mai

DFCL / DFCL-ECM | Management system for a network of fan coils

RS 485 serial connection cable

Shielded cable to be used:

Belden 9841, RS-485, 1x2x24 AWG SFTP, 120 Ohm



PC NET Software

Connection of a DFCL network with QCV-MB control board

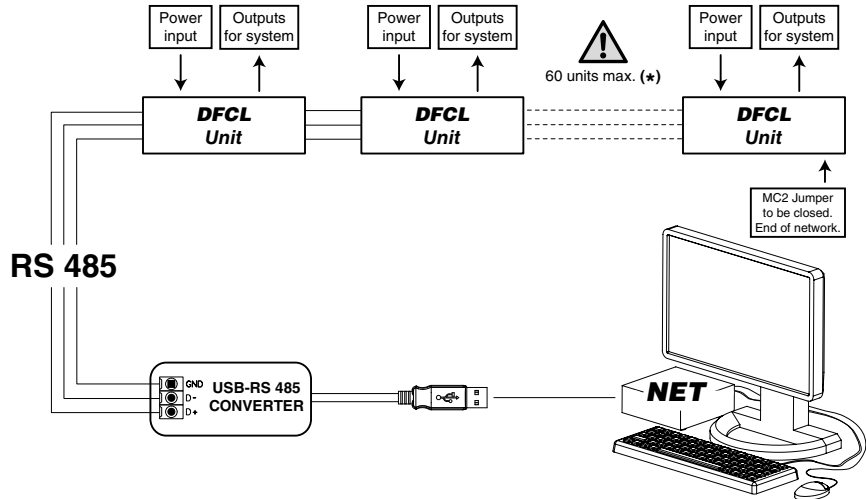

(*) In the event

of more than 60 units, add one or more Router-S (see below).

PSM-DI accessories and NET

IDENTIFICATION	CODE
SIOS	3021292

SIOS is a board equipped with 8 relays with potential free contact to control the activation or deactivation of remote electric utilities. Moreover, the board has 8 digital inlets to display the actuators or external consents, such as motor or other.

The SIOS boards can be connected:

- inside a network managed by NET
- inside a network managed by T-DI
- inside a network managed by Web gateway
- to a PSM-DI panel (one SiOS for each PSM-DI panel)



IDENTIFICATION	CODE
Router-S	3021290

The Router-S is an electronic board that allows to control several units inside a network managed by NET (default) or within a sub-network managed by BMS systems, that are not provided (it is necessary to operate on a Dip Switch on the board).

Managed by NET

The Router-S in the standard version is an electronic board that:

- allows creating networks with more than 60 units (minimum 2 Router-S are required) or to divide the network (per floor, building, etc.);
- allows creating a Master/Slave sub-network to be controlled as an independent group.

The number of Router-S to be used is:

- up to 60 units: no Router-S
- from 61 to 120 units: 2 Router-S
- every 60 subsequent units: 1 additional Router-S



Managed by BMS Systems which are not provided

The Router-S becomes an electronic board to use with BMS systems not supplied, only after having set the Dip Switch on the board and so creating a Master/Slave sub-network to be controlled as an independent group.

The number of Router-S to use is:

- maximum 14 Router-S
- maximum 15 Fan Coils per Router-S

BCM External auxiliary condensate collection tray

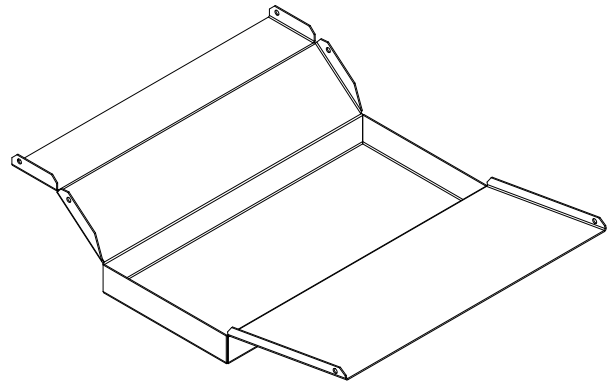

MODEL	Code
ALL	9034029

SFM G4 synthetic filter ePM₁₀ 50% class

The filter is a washable synthetic fibre, flame-proof according to Class F1 DIN 53438. Efficiency of 84%, Eurovent EU3.

The filter is supplied as an accessory and must be fitted on the unit on site in place of the standard filter.

MODEL	A	B	C	Code
DFCL 1 DFCL-ECM 1	48	285	1000	6034050
DFCL 2 DFCL-ECM 2	48	285	1000	6034050
DFCL 3 DFCL-ECM 3	48	335	988	6034052
DFCL 4 DFCL-ECM 4	48	335	1298	6034053
DFCL 5 DFCL-ECM 5	48	410	1298	6034054
DFCL 6	48	460	1385	6034056
DFCL 7	48	560	1385	6034057

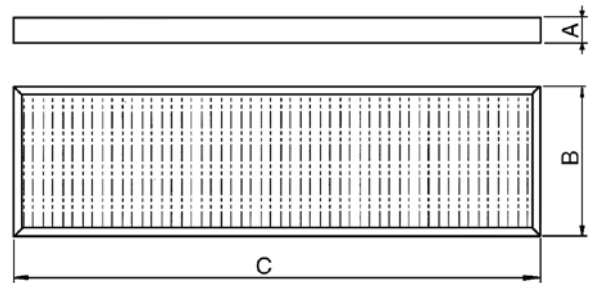

SFM F6 synthetic filter ePM₁₀ 70% class

High efficiency compact filter in glass microfiber paper, Class F6 in according to EN779.

The filter is supplied as an accessory and must be fitted on the unit on site in place of the standard filter.

MODEL	A	B	C	Code
DFCL 6	98	460	1385	6034197
DFCL 7	98	560	1385	6034198

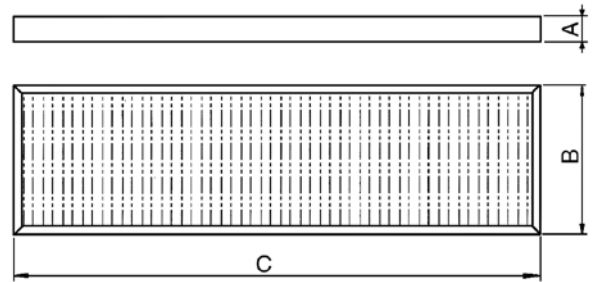

PMM Intake/supply spigot plenum

Intake/supply spigot plenum with 3 spigots (Sizes 1-2-3) or 4 spigots (Sizes 4-5-6-7).

MODEL	A	B	C	N° Spigots	∅ Spigots	Code
DFCL 1 DFCL-ECM 1	1133	182	298	3	250	9034200
DFCL 2 DFCL-ECM 2	1133	182	298	3	250	9034200
DFCL 3 DFCL-ECM 3	1133	182	348	3	250	9034220
DFCL 4 DFCL-ECM 4	1445	300	348	4	250	9034230
DFCL 5 DFCL-ECM 5	1445	300	442	4	300	9034240
DFCL 6	1535	300	472	4	355	9034280
DFCL 7	1535	300	572	4	355	9034290

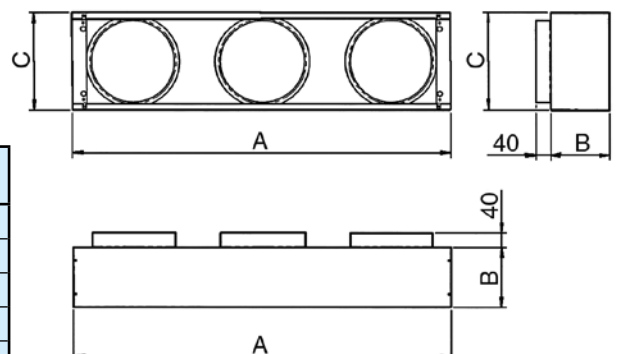

GAV Antivibrating connection

Intake/supply antivibrating connection, made of two galvanized frames and a PVC flexible connection.

MODEL		A	B	Code
DFCL 1	DFCL-ECM 1	1138	296	6034200
DFCL 2	DFCL-ECM 2	1138	296	6034200
DFCL 3	DFCL-ECM 3	1138	346	6034201
DFCL 4	DFCL-ECM 4	1450	346	6034202
DFCL 5	DFCL-ECM 5	1450	421	6034203
DFCL 6		1540	461	6034204
DFCL 7		1540	561	6034205



BEM Electric heater

The **BEM** electric coil consists of electric resistances and a security thermostat, which are inside a galvanized steel and insulated casing.

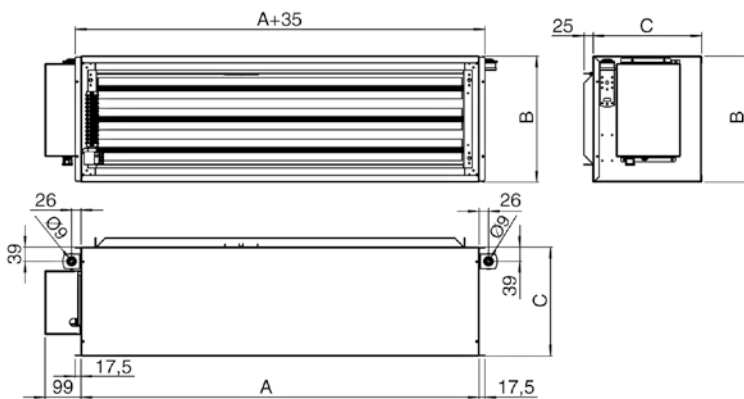
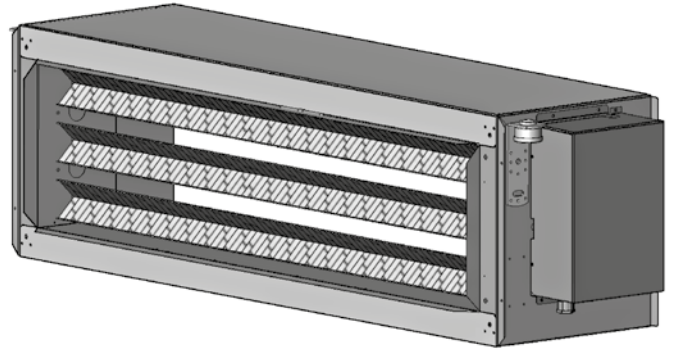

MODEL	A	B	C	WATT		V	Code
				1° stage	TOTAL		
DFCL 1 DFCL-ECM 1	1098	297	300	2000	3000	230	9034201
DFCL 2 DFCL-ECM 2	1098	297	300	3000	4500	230	9034210
DFCL 1 DFCL-ECM 1	1098	297	300	2000	3000	400	9034202
DFCL 2 DFCL-ECM 2	1098	297	300	3000	4500	400	9034211
DFCL 3 DFCL-ECM 3	1098	347	300	5000	7500	400	9034222
DFCL 4 DFCL-ECM 4	1410	347	300	5000	7500	400	9034232
DFCL 5 DFCL-ECM 5	1410	422	300	7500	15000	400	9034242
DFCL 6	1500	472	300	7500	15000	400	9034204
DFCL 7	1500	572	300	7500	15000	400	9034205

Electronic wall controls for **BEM** Electric heater (optional)

For **DFCL** models

WM-TQR	3 speed control with electronic thermostat and centralized/manual summer/winter switch
WM-AU	Automatic speed control with electronic thermostat and summer/winter switch (to be used with UPOM-AU or UPO-AU only)
T-MB	Wall control (to be used with UPOM-AU or UPO-AU only)

For **DFCL-ECM** models

WM-AU	Automatic speed control with electronic thermostat and summer/winter switch (to be used with UPOM-AU or UPO-AU only)
T-MB	Wall control (to be used with UPOM-AU or UPO-AU only)

For more details about the controls, see the related pages within this document.

TO BE USED ONLY WITH QCV-MB CONTROL BOARD

**24 V
main coil kit valve**

1" Valve
with 3 points - 24 Volt actuator *



MODEL		H	L	Ø Connections	Kvs	Code
DFCL 1	DFCL-ECM 1	54	245	1"	6,3	9034250
DFCL 2	DFCL-ECM 2	54	245	1"	6,3	9034251
DFCL 3	DFCL-ECM 3	54	295	1"	6,3	9034251
DFCL 4	DFCL-ECM 4	58	291	1"	10	9034252
DFCL 5	DFCL-ECM 5	58	367	1"	10	9034252
DFCL 6		59	416	1"	10	9034270
DFCL 7		59	516	1"	10	9034272

Left connections (standard)

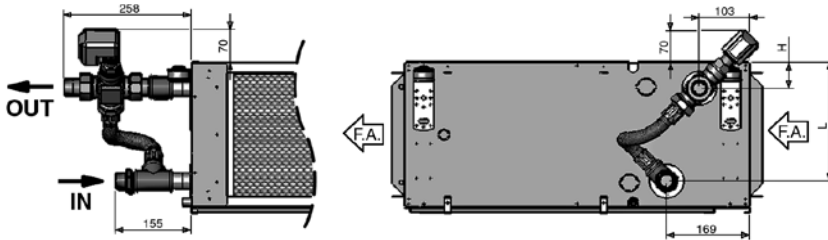

Right connections (on request)

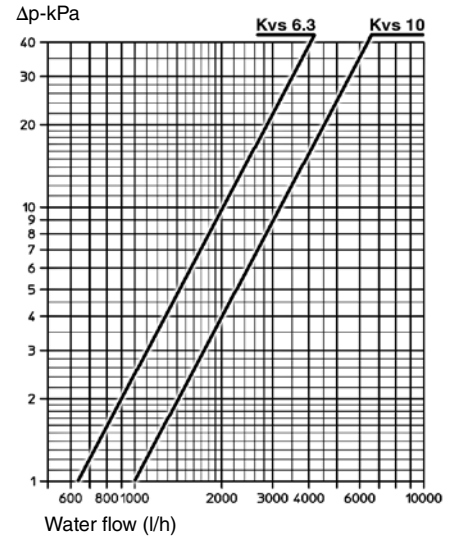
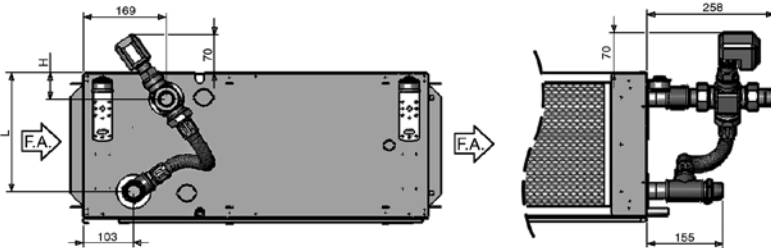

**24 V
auxiliary coil kit valve**

1" Valve
with 3 points - 24 Volt actuator *



MODEL		M	N	Ø Connections	Kvs	Code
DFCL 1	DFCL-ECM 1	50	249	1"	6,3	9034253
DFCL 2	DFCL-ECM 2	50	249	1"	6,3	9034253
DFCL 3	DFCL-ECM 3	50	299	1"	6,3	9034253
DFCL 4	DFCL-ECM 4	54	295	1"	10	9034254
DFCL 5	DFCL-ECM 5	54	370	1"	10	9034254
DFCL 6		55	421	1"	10	9034271
DFCL 7		55	521	1"	10	9034273

Left connections (standard)

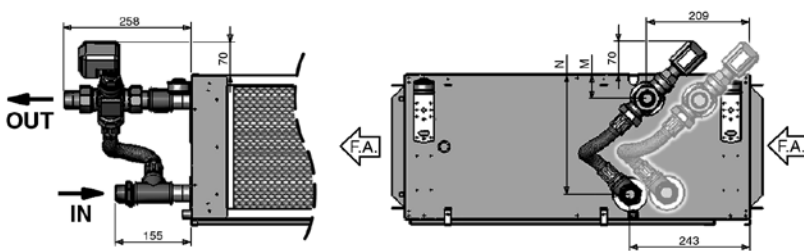

Right connections (on request)

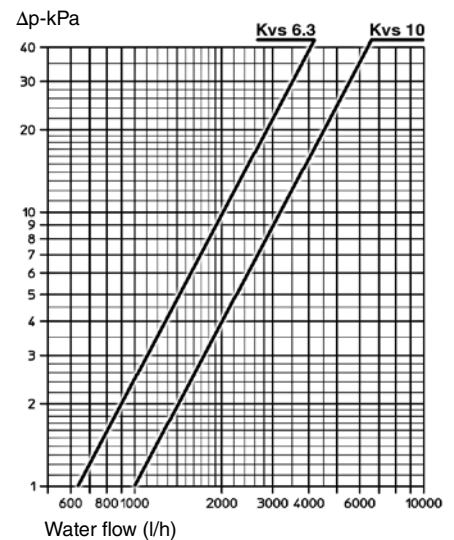
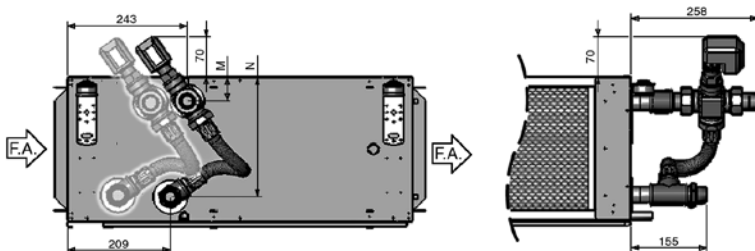

* The valves can't be used with WM-T and WM-TQR controls.

TO BE USED ONLY WITH ON/OFF 230 V CONTROLS (QCV-MB, WM-T and WM-TQR)

**230 V
main coil kit valve**

3/4" 230 V, ON-OFF valve.



MODEL		H	L	Ø Connections	Kvs	Code
DFCL 1	DFCL-ECM 1	54	245	3/4"	10	9034255
DFCL 2	DFCL-ECM 2	54	245	1"	10	9034256
DFCL 3	DFCL-ECM 3	54	295	1"	10	9034256
DFCL 4	DFCL-ECM 4	58	291	1 - 1/4"	10	9034257
DFCL 5	DFCL-ECM 5	58	367	1 - 1/4"	10	9034257
DFCL 6		59	416	1 - 1/4"	10	9034259
DFCL 7		59	516	1 - 1/4"	10	9034259

Left connections (standard)

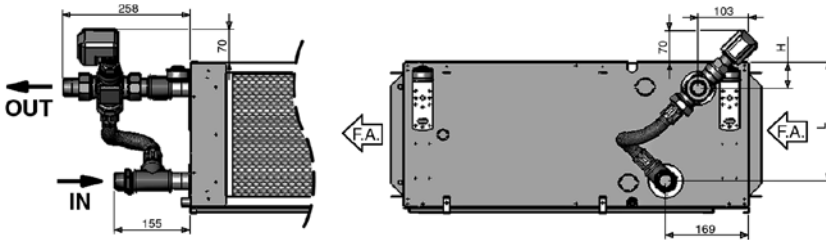

Right connections (on request)

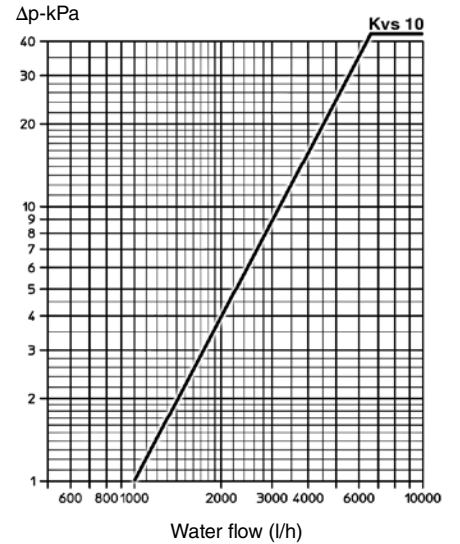
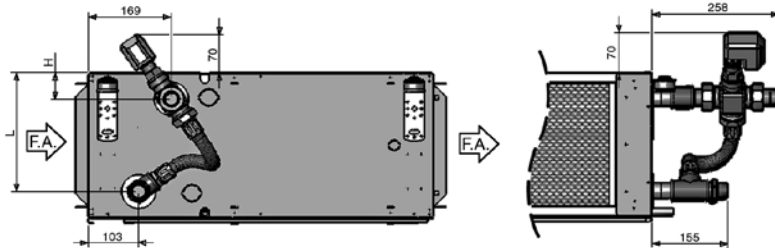

**230 V
auxiliary coil kit valve**

3/4" 230 V, ON-OFF valve.



MODEL		H	L	Ø Connections	Kvs	Code
DFCL 1	DFCL-ECM 1	50	249	3/4"	10	9034255
DFCL 2	DFCL-ECM 2	50	249	3/4"	10	9034255
DFCL 3	DFCL-ECM 3	50	299	3/4"	10	9034255
DFCL 4	DFCL-ECM 4	54	295	1"	10	9034256
DFCL 5	DFCL-ECM 5	54	370	1"	10	9034256
DFCL 6		55	421	1"	10	9034258
DFCL 7		55	521	1"	10	9034258

Left connections (standard)

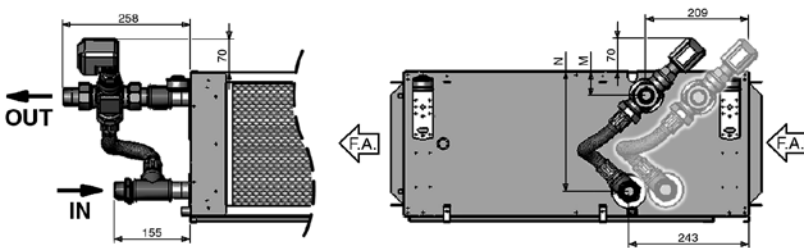

Right connections (on request)

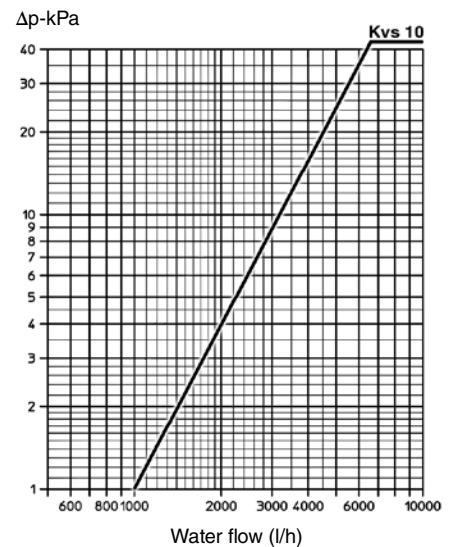
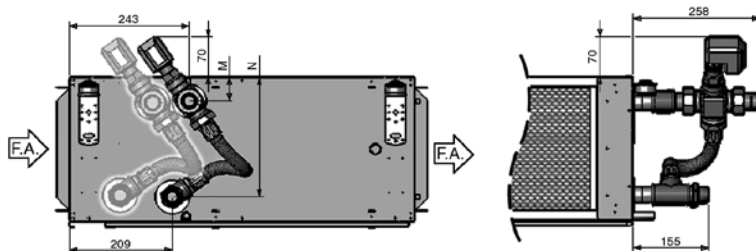

The descriptions and illustrations provided in this publication are not binding: we reserves the right, whilst maintaining the essential characteristics of the types described and illustrated, to make, at any time, without the requirement to promptly update this piece of literature, any changes that it considers useful for the purpose of improvement or for any other manufacturing or commercial requirements.

 **ALARKO**



**ALARKO CARRIER
SANAYİ VE TİCARET A.Ş.**

GOSB-Gebze Organize Sanayi Bölgesi
Şahabettin Bilgisu Cad. 41480 Gebze-Kocaeli/TURKEY

Phone : (90)(262) 648 60 00 PBX

Telefax : (90)(262) 648 61 01

web : www.alarko-carrier.com.tr

e-mail : info@alarko-carrier.com.tr