



Floor Type Condensing Boiler Aldens F Series



Large project solutions with the possibility of cascade reaching up to 18,400 kW with 16 units



aldens

LOW EMISSION
**ECO-FRIENDLY
BOILER**



Floor Type Premix Condensing Boiler

Superior Features of the Aldens F Series:

- Ideal air-gas blend with premix system, high efficiency, low noise level, low flue gas temperature and low emission rate, environmentally friendly product
- Compatible with natural gas.
- Long-lasting, durable, stainless steel exchanger
- Useful heating efficiency in the range of 93.7-98.97% (at 50/30°C),
- With its aesthetics and modern colors the new Aldens F series boiler adds value to your apartment.
- Large project solutions with the possibility of cascade reaching up to 18,400 kW with 16 units
- Internal flue gas flap available in all types,
- Wheels with stop mechanism on 310, 350 and 425 kW models,
- Wide heating modulation range and minimum stop-start, maximum fuel saving (16-100%)
- 6 bar maximum operating pressure
- Provided with 6 bar safety valve and expansion tank connection piece
- High quality and durability with Siemens electronic board, Sermeta stainless steel exchanger
- Suitable for natural gas,
- Small space occupancy in boiler rooms with very small dimensions in contrast to their capacities
- Connection system for ease of service and quick installation
- Complies with EN 15502 standard (gas-fired central heating boilers with a rated heat load not exceeding 1,000 kW)
- EMC (Electromagnetic Compatibility) and LVD (Low Voltage Directive) compliant
- Since the cascade and expansion modules that may be required as accessories according to the installation need are of very small size and are mounted in their places at hand in the boiler, the problems of fixing and long wiring to the wall or boiler room electrical panel required in the modules mounted on the boiler room wall are eliminated
- Wide range of affordable accessories (control module and sensors, high energy class pumps, neutralizers)
- Ease of service with streamlined and fast module connections, quick heat exchanger maintenance without draining the installation water
- Wide range of controls and accessories
- Competitive prices...
- Cost-effective spare parts.



Elegant and Modern Design

- Small space occupancy in boiler rooms with very small dimensions in contrast to their capacities
- 13 types in total with 13 different capacities
- Capacities including 175, 196.1, 228.9, 254.7, 306.7, 346, 425, 500, 575, 700, 850, 1000, 1150 kW (at 50/30°C)
- Control card protection box with utility model documentation
- For an easy connection, all the necessary mains and signal outputs are transferred to the terminal box at the back of the front cover by means of terminal boxes.
- CE and TSE certified



F-175
F-200
F-235
F-265

F-310 F-500 F-850
F-350 F-575 F-1000
F-425 F-700 F-1150

CONTROL PANEL and INDICATORS



Selection and confirmation button



Reset button

Navigation bar

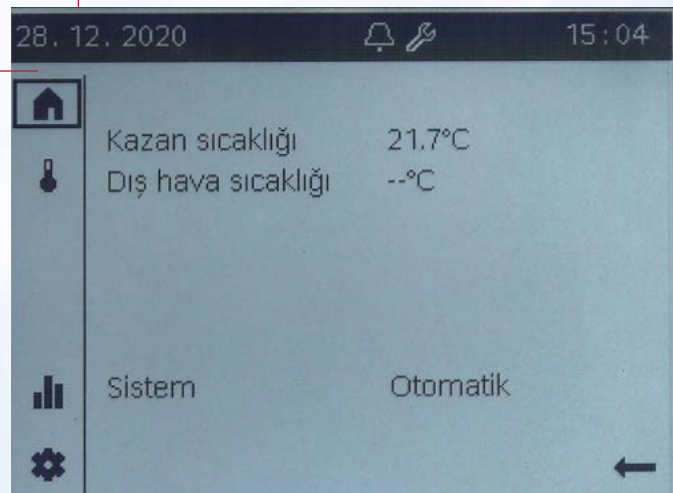

Accessible by end user and experts:



Welcome page: Facility status.
Access to the facility key (or area key).



Temperature page: Heating access.



Information pages:

- Messages (errors, events)
- Facility information
- Time-based energy data and consumption



Service / settings page:

- Setting options on the device or plant
- Special mode operation (e.g. for maintenance operation)
- Entrance to expert level

In addition for experts:



Diagnostic pages: Analysis and testing of the plant.



Settings and maintenance:

- Adaptation of parameters in "All parameter list"
- Access to commissioning wizards

CASCADE WORK SYSTEM



- Up to 16 identical aging cascade boiler connection possibilities
- In the cascade system, the 1st boiler is activated in the first place with its leadership duty when there is a need for heat. At the end of the specified period, it transfers the leadership task to the 2nd boiler. In this way, the boilers operate equally for many years.
- In cascade operation, the lowest system modulation rate and thereby the highest efficiency is achieved by the activation of a large number of boilers with the early entry, late exit-system.
- Even if one or more boilers malfunction, the other boilers continue to operate and the heating system continues to operate continuously.

Excellent Components **SUPERIOR QUALITY**

EXCHANGER (Heat Exchanger)

Quiet, Long-lasting and Environmentally Friendly

- Made from **Sermeta** brand cylindrical, smooth, long-lasting stainless steel
- Highly efficient, robust, resistant to thermal shocks
- Bluejet® burner which is developed by Sermeta, the burner of the exchanger is a patented is very quiet and long-lasting
- The exchanger which has low CO² footprint can be 100% recycled
- Quick maintenance can be performed by removing only a few nuts and easily reaching the combustion cell

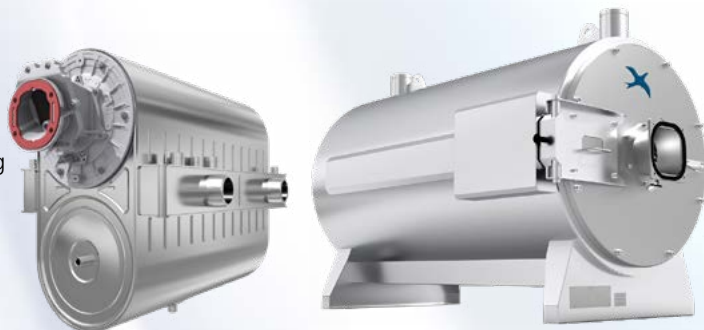

MAIN BOARD

- The newest **Siemens** brand LMS14 card is used
- Controlling heating, domestic water, and solar energy applications
- Protection of the heat exchanger from thermal stresses with the excessive ΔT (delta T) prevention system
- Parameter upload via parameter bar (micro circuit board)
- Time program for heating, boiler, and an external relay
- Additional circuit control with 3 expansion module connection possibilities
- 1x 230 V energy outlet
- 3x 230 V relay outputs: assigned as boiler pump (stepped), direct circuit pump, and boiler pump (1 separation on/off three-way valve can be connected)
- Modulated pump control with 1 PWM (pulse width modulation) connection
- 4 empty sensor connections (outdoor air, cascade, and boiler sensors assigned, one not assigned)
- 3 digital inputs (e.g. with 3 room thermostat connections, on/off control of 3 separate heating circuits, or swimming pool control)
- Comfort/economy location and boiler water change of 2 separate heating circuits with 2 x indoor unit connection



FAN - VENTURI ASSEMBLY, GAS VALVE

- The required amount of air-gas blend is provided depending on the boiler capacity with the **FASCO** brand modulated fan. The fan speed increases or decreases depending on the capacity. Thus, both low noise level is maintained and low efficiency due to excess air is not in question.
- The **Honeywell** and **Resideo** gas valve safely provides the gas flow required for combustion, depending on the varying speed of the modulated fan according to capacity
- With **Honeywell** and **Resideo** venturies, the ideal air-gas blend ratio of 1:10 is ensured to be constant throughout the entire capacity range. This is the most important factor that ensures efficiency and a clean combustion.



IMPORTANT COMPONENTS

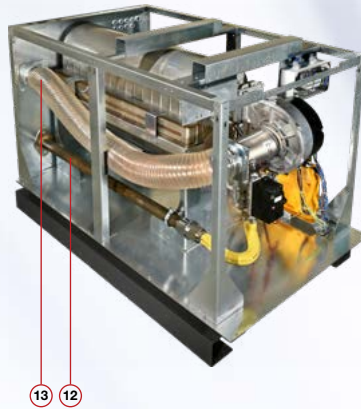
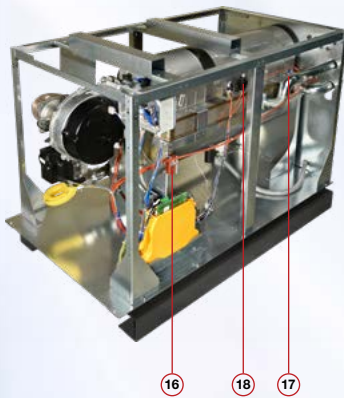
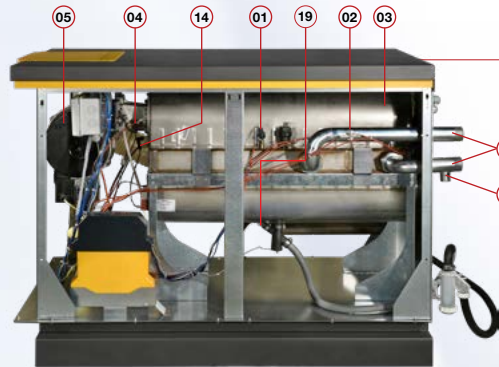
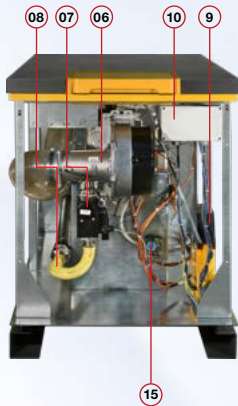

ALDENS F SERIES - 175 / 200 / 235 / 265

- 01. Pressure Sensor
- 02. Limit Thermostat
- 03. Exchanger
- 04. Ignition / Ionization Electrode
- 05. Fan
- 06. Venturi
- 07. Gas Valve
- 08. Gas Connection
- 09. Control Card
- 10. Signal terminal box
- 11. Installation Water Outlet / Return Pipe
- 12. Gas Connection
- 13. Fresh Air Connection
- 14. Limit Thermostat
- 15. Pressure switch
- 16. Ignition Transformer
- 17. Temperature Sensor
- 18. Air Purifier
- 19. Siphon Sensor
- 20. 6 Bar Safety Valve

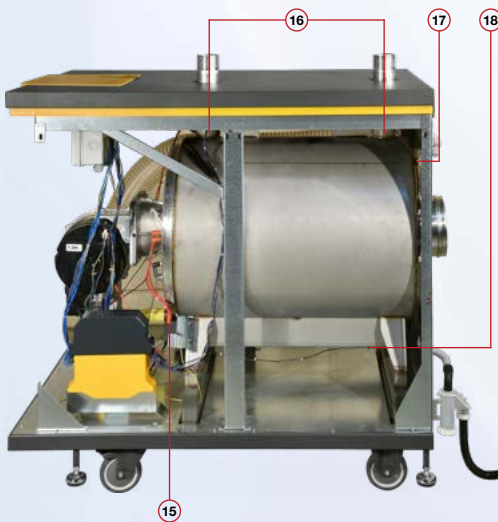

ALDENS F SERIES - 310 / 350 / 425 500 / 575 / 700 / 850 / 1000 / 1150

- 01. Pressure Sensor
- 02. Limit Thermostat
- 03. Exchanger
- 04. Ignition / Ionization Electrode
- 05. Fan
- 06. Venturi
- 07. Gas Valve
- 08. Gas Connection
- 09. Control Card
- 10. Electrical Box
- 11. Installation Water Outlet / Return Pipe
- 12. Gas Connection
- 13. Fresh Air Connection
- 14. Limit Thermostat
- 15. Ignition Transformer
- 16. Temperature Sensor
- 17. 6 Bar Safety Valve
- 18. Siphon Sensor

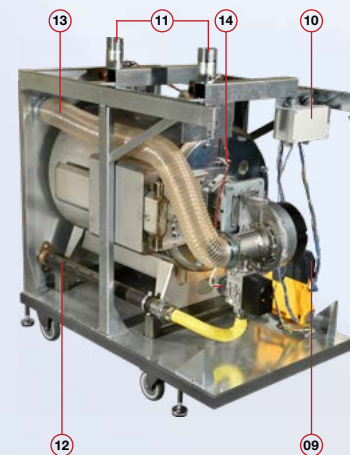
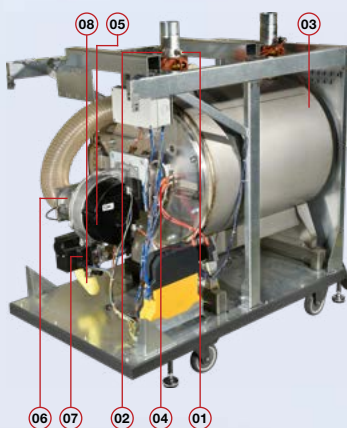

Hi-Safety FULL CONTROL

CONTROL MODULE, SENSOR AND TOOLS

OCI345.06/101 Cascade Module

Cascade systems must be located in each boiler in the system for multiple boiler control.



AGU2,550x109 Expansion Module

Used for 1 blend circuit check (3-way blend valve + pump + flow sensor) check or 3 direct circuit pump feeds. There is an additional 1 sensor output (for solar collector sensor or swimming pool sensor, etc.). 3 expansion modules can be installed in each boiler.



QAC34/101 Outdoor Air Sensor

It is used to operate boilers according to external weather conditions. Mandatory to use one in each cascade system.



QAZ36.522/109 Immersion Type Sensor

Used as a boiler sensor, balance vessel sensor, etc.



QAZ36.481/101 Immersion Type Sensor

Used as a solar collector sensor. It can measure up to 200°C.

QAD36/101 Clamp Type Sensor

It is used for depart and return water sensors. If the plate exchanger is used as the primary-secondary circuit separator, it is placed in the exit after the exchanger.



RAA 21 Room Thermostat

Used for zone control. Operates the boiler according to the set temperature (in the direct circuit or blend circuit). There are a total of 3 room thermostat connections in each boiler.



QAA55.110/101 Indoor Room Unit

Used for zone control (direct circuit or blend circuit). Changing the comfort / economy status increasing / decreasing the boiler water temperature. 2 indoor units can be connected to each boiler.



OZW672 Web Server

System control, monitoring and settings can be made by accessing single boiler or cascade systems via remote web server via computer or smart phone. There are types that can control 1 device, up to 4 devices and up to 16 devices (OZW672.01/04/16). Error message and periodic report are sent by e-mail to up to 4 users registered in the system. The menu is in Turkish.



OCI351.01/109 Modbus Communication Module:

Modbus is used for communication with the building management system. For communication, it is sufficient to connect only one module to the leading boiler. If the values of all boilers need to be seen separately, one should be installed in each boiler.



ACCESSORIES

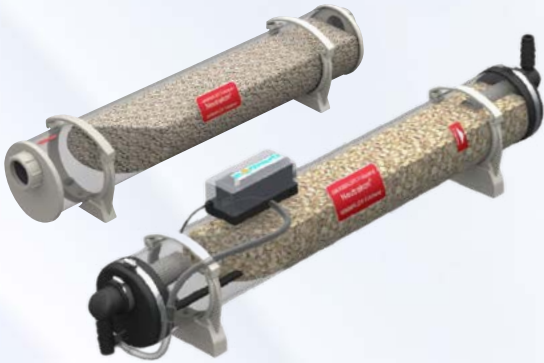

Neutralizers

It is obligatory to use a neutralizer that neutralizes acidic condensate in installations of 200 kW and above.
 pH before neutralization in natural gas:
 3,5-4, pH after neutralization:
 after neutralization is between 6-7.

Models suitable for Aldens F:

Neutrakon® 04/BGN with auxiliary pump for < 300 kW and

Neutrakon® 08/BGN with auxiliary pump for < 650 kW



Safety Valve

Mandatory to use in each boiler, safety valves are provided free in a boiler packaging as 6 bar safety valve. The expansion tank opening on it provides an advantage in additional accessory cost and workmanship.

DIMENSIONS

ALDENS F 175 - 200 - 235 - 265 kW

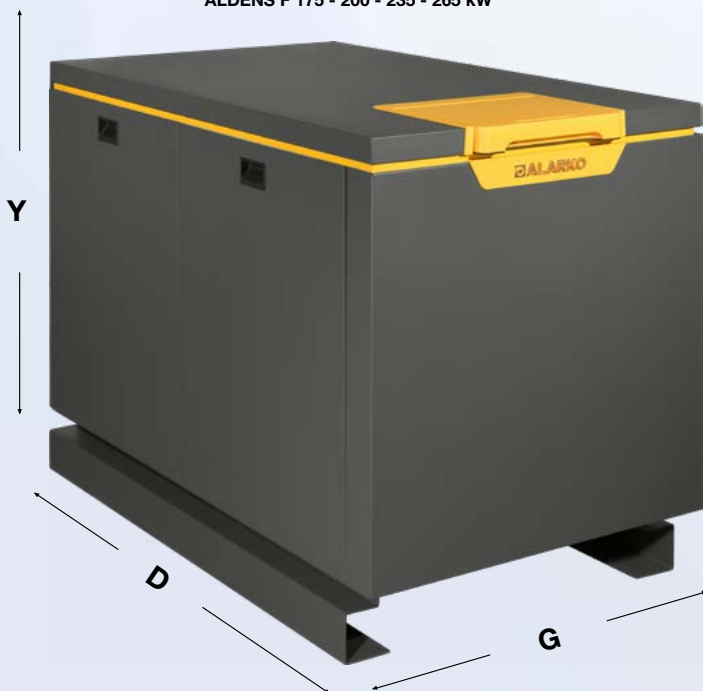

ALDENS F 310 - 350 - 425 - 500 - 575 - 700 - 850 - 1000 - 1150 kW

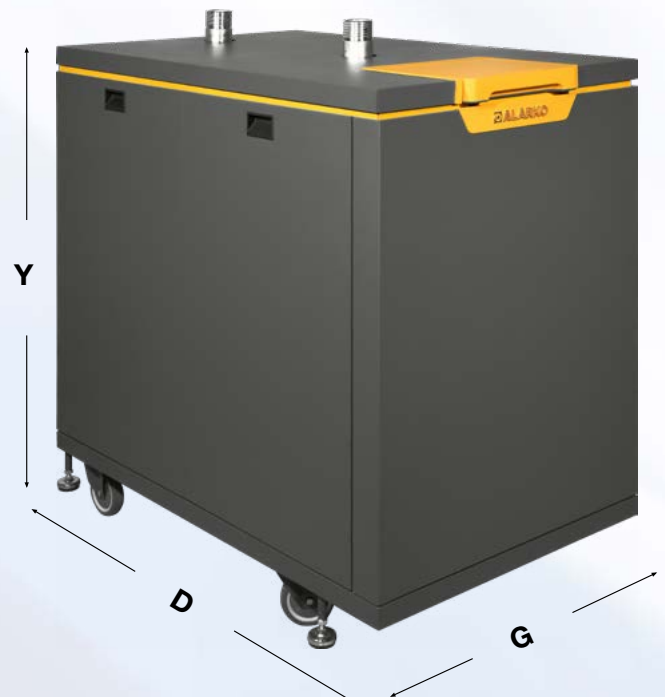

TECHNICAL SPECIFICATIONS	UNIT	ALDENS F						
		175	200	235	265	310	350	425
Fuel	-	Natural Gas (G20)						
Inlet Pressure	mbar	20						
Fuel Consumption at Maximum Load (50/30 °C)	m³/h	16,1	19	23,51	27,57	31,63	38,7	394,0
Fuel Consumption at Minimum Load (50/30 °C)	m³/h	2,9	2,83	4,01	4,61	4,96	7,04	68,8
Technical Parameters								
Erp Directive								
P _{rated}	kW	161	182	212	238	281	317	394
P _n - Nominal Thermal Power (50/30°C)	kW	175	196,1	228,9	254,7	306,7	346	425
P ₄ - Thermal Power @ Max Power (80/60 °C)	kW	161	181,9	212,1	238,2	281,3	317,1	394
P ₁ - Thermal Power @ Partial Load	kW	31,8	64,6	69,22	77,53	90,68	98,97	77
η ₄ - Useful Efficiency @ Max Load (80/60 °C)	%	87,01	86,96	86,77	87,4	86,49	86,51	87,86
η ₁ - Useful Efficiency @ Partial load (50/30 °C)	%	97,5	96,72	96,44	93,7	95,36	98,97	97,17
NOx Class	-	6						
Rated Heat Load Max / Min	kW	167,0/29,0	189,0/30,0	220,0 /37,0	245,0/40,0	293,0/47,0	330,0/55,0	405,0/71,0
Max/ Min Power (50/30 °C)	kW	175,0/31,2	196,1/31,9	228,9/39,4	254,7/42,4	306,7/49,0	346 /58,2	425,0/76,4
Max/ Min Power (80/60 °C)	kW	161,00/27,9	181,90/28,9	212,10/34,9	238,20/38,1	281,30/44,6	317,10/51,8	394,00/68,8
NOx Emission	Mg/kWh	32	54,9	53,73	45,52	52	55,6	44
Electrical Supply (Voltage/Frequency)	VAC/Hz	230 / 50						
Fuse to be Used	A	6,3						
Electricity Consumption in Standby (Off) State	W	4						
Max/Min Electricity Consumption	W	252/50	223/44	290/62	389/67	445/81	546/84	741/69
IP	-	4						
Installation								
Gas Connection	inch	1 ½ "	1 ½ "	1 ½ "	1 ½ "	2 "	2 "	2 "
Water Outlet / Return Connections	inch	1 ½ "	1 ½ "	1 ½ "	1 ½ "	2 ½ "	2 ½ "	2 ½ "
Maximum Operating Pressure	bar	6						
Minimum Operating Pressure	bar	1						
Max Flow Rate	m³/h	7,2	8,1	9,4	10,5	12,6	14,2	17,4
Boiler Water Volume	lt	14,5	17	17	19,5	41,5	41,5	48,9
Max Operating Temperature	°C	85						
General Specifications								
Net Appliance Dimensions (W x D x H)	mm	793x1247x1002	793x1247x1002	793x1247x1002	793x1355x1002	816x1182x1265	816x1182x1265	816x1306x1265
Packaging Dimensions (W x D x H)	mm	970x1545x1000	970x1545x1000	970x1545x1000	970x1645x1000	970x1545x1000	970x1545x1000	970x1645x1000
Device Weight	kg	211,5	225,5	232	242,5	385	385	423
Packaging Weight	kg	241	255	261,5	278,5	425,5	425,5	463,5
Flue pipe diameter	mm	150	150	150	150	200	200	200
Type	-	Hermetic / Full condensing						
Ignition System	-	Electronic						
Floor heating	-	Yes						
Cascade Operation	-	Maximum 16						
Freeze Protection	-	Yes						

TECHNICAL SPECIFICATIONS	UNIT	ALDENS F					
		500	575	700	850	1000	1150
Fuel	-	Natural Gas (G20)					
Inlet Pressure	mbar	20					
Fuel Consumption at Maximum Load (50/30 °C)	m ³ /h	50,3	56,7	65,6	84,7	87,11	98,8
Fuel Consumption at Minimum Load (50/30 °C)	m ³ /h	8,57	9,47	11,35	14,4	17,2	17,3
Technical Parameters							
Erp Directive							
P _{rated}	kW	454	529	640	762	909	1045
P _n - Nominal Thermal Power (50/30°C)	kW	496,4	575	700	850	1000	1150
P ₄ - Thermal Power @ Max Power (80/60 °C)	kW	454	528,5	640	761,6	908,6	1044,6
P ₁ - Thermal Power @ Partial Load	kW	147,4	173,4	210,4	148,6	172	196
η ₄ - Useful Efficiency @ Max Load (80/60 °C)	%	86,1	86,7	87,6	86,6	87,8	87,7
η ₁ - Useful Efficiency @ Partial load (50/30 °C)	%	94,14	95,3	97,09	95,1	97,3	97
NOx Class	-	6					
Rated Heat Load Max / Min	kW	550/90	660/116	800/140	934/170	1075/195	330,0/55,0
Max/ Min Power (50/30 °C)	kW	575/94	700/147	850/148,6	1000,7/180,9	1150,6/209,4	346 /58,2
Max/ Min Power (80/60 °C)	kW	528,5/85	640/112	761,6/134,4	908,6/166,2	1044,6/188,8	317,10/51,8
NOx Emission	Mg/kWh	45,4	39	33	34	36	55,6
Electrical Supply (Voltage/Frequency)	VAC/Hz	230 / 50			400 / 50		
Fuse to be Used	A	6,3					
Electricity Consumption in Standby (Off) State	W	4			6		
Max/Min Electricity Consumption	W	901/98	966/85	1183/61	1315/59	1873/60	2065/71
IP	-	4					
Installation							
Gas Connection	inch	2 "	2 "	2 "	2 "	2 "	2 "
Water Outlet / Return Connections	inch	2 ½ "	2 ½ "	2 ½ "	2 ½ "	2 ½ "	2 ½ "
Maximum Operating Pressure	bar	6					
Minimum Operating Pressure	bar	1					
Max Flow Rate	m ³ /h	21,8	24,3	28,7	34	39	44
Boiler Water Volume	lt	48,9	61,5	61,5	74,8	130,9	130,9
Max Operating Temperature	°C	85					
General Specifications							
Net Appliance Dimensions (W x D x H)	mm	816x1306x1265	816x1690x1360	816x1690x1360	1250x2200x1650	1250x2200x1750	1250x2200x1750
Packaging Dimensions (W x D x H)	mm	970x1645x1000	970x1910x1400	970x1910x1400	1320x2300x1800	1320x2300x1900	1320x2300x1900
Device Weight	kg	423	500	500	680	830	830
Packaging Weight	kg	463,5	549	549	800	950	950
Flue pipe diameter	mm	200	250	250	250	300	300
Type	-	Hermetic / Full condensing					
Ignition System	-	Electronic					
Floor heating	-	Yes					
Cascade Operation	-	Maximum 16					
Freeze Protection	-	Yes					

